

ROOF PLAN AS EXISTING  
1:50 @ A3

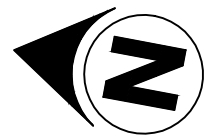

FRONT ELEVATION AS EXISTING  
1:100 @ A3



REAR ELEVATION AS EXISTING  
1:100 @ A3

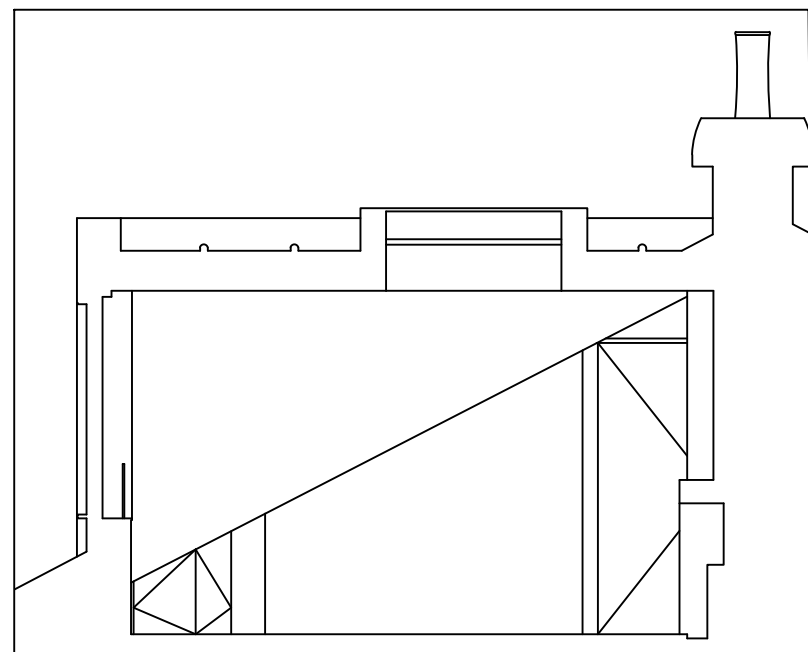

SECTION A-A AS EXISTING  
1:50 @ A3

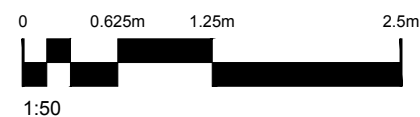

This Drawing is based on Survey information  
supplied by Others

Client	Drawing No TWP17-PR-002 Revision	<b>the winter partnership</b> chartered building surveyors property consultants 24 rottingdean place falmer road brighton bn2 7fs t 01273 309601 f 01273 271184 e scooper@winterpartnership.co.uk
Contract 12 Provost Road London	Date Feb '17 Scales 1:50/100@A3	
Drawing Roof plan, Section A-A & Rear Elevation As Existing	Drawn CAB Checked SC	