

NS/GF/AB/PD9635

email: [gareth.fox@montagu-evans.co.uk](mailto:gareth.fox@montagu-evans.co.uk)

5<sup>th</sup> April 2016

Planning and Development Control  
Camden Council  
5 Pancras Square  
London  
N1C 4AG

Dear Sir / Madam,

**6-10 CAMBRIDGE TERRACE AND 1-2 CHESTER GATE, CAMDEN, NW1  
APPLICATION FOR LISTED BUILDING**

We write on behalf our client, Project Quad Limited, to seek Listed Building Consent for a new rooflight to replace that permitted by Planning Permission ref. 2009/3041/P and Listed Building Consent ref. 2009/3051/L and subsequently amended via a Section 73 application ref. 2015/1340/P and Listed Building Consent 2015/1817/L.

For information, we note that a condition was added to permission ref. 2009/3041/P, listing the approved drawings (via Section 96a non-material amendment ref. 2015/1778/P). This amendment facilitated the Section 73 application 15/1340/P.

In early 2015, a further Section 96a non-material amendment (ref. 2015/6946/P) and corresponding Listed Building Consent (ref. 2015/6549/L), were approved allowing various internal layout changes and revised roof lights.

**Proposals**

Due to Building Regulations, it has become necessary to make a further revision the proposed sliding roof light highlighted in red on drawing number SK02 – Roof Plan Key.

Building Regulations require roof lights to be proud of the prevailing roof plane by a minimum upstand of 150mm. This ensures that water ingress is prevented. The approved plans do not allow for this and thus the roof light cannot be constructed in its permitted form.

Previously, the design team have proposed a raised roof light in this location. The design was put to Conservation Officer, Charlie Rose to seek his opinion on the design. He explained that the upstand made the window inappropriately conspicuous atop the listed building and he sort reassurance that it would not be or that a lower profile alternative could be found.

The new design approach means the full upstand height required by building regulations is achieved, with only a small amount of that height appearing above the prevailing roof line. This is achieved by sinking the window into the roof plane and using a sunken 'gutter' around the top of the window to achieve the necessary upstand height.

An extract below from the proposed section highlights the design feature.

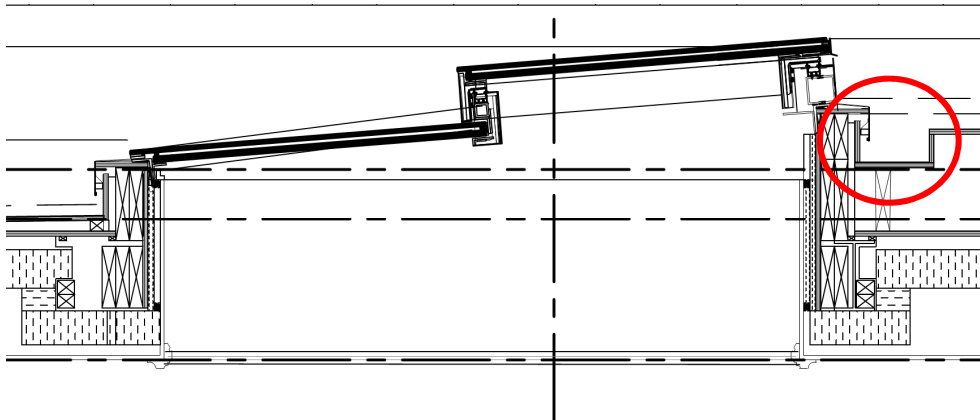

CPC's architects have worked extremely hard to find a solution, ensuring that the window remains visually discrete. The proposals are now 150mm lower than those which Charlie Rose considered to be too tall. This reduction in height will prevent the window being visible in all but the longest views of the terrace as its tallest point is set 4.5 metres from the edge of the roof. The length of the views from which the window may be seen would be so great as to mean it would be barely discernible against the background of other, far taller, rooftop structures previously permitted by the council.

It is also worth noting that the roof light's height at the lower end, is 150mm. This is the height at which such installations become permitted development under Class C of the General Permitted Development Order 2016. This suggests the window as a whole is in fact close to being so minor as to be permitted development, thus reinforcing the suggestion that the window's profile will be extremely low and visually insignificant.

It is our opinion therefore that the changes preserve the character and appearance of the listed building, the Regent's Park Conservation Area, Regent's Park itself and the setting of all other nearby Designated Heritage Assets. As such, we are of the view that these changes are acceptable, both in planning and heritage terms.

### **Application Material**

The following documents accompany these applications:

- Completed Application Form prepared by Montagu Evans;
- Cover Letter (this letter) prepared by Montagu Evans;
- Application Drawings prepared by CPC:
  - SK01 – Roof Key Plan
  - SK02 – Roof Plan
  - SK03 – Roof Section
  - SK04 – Front Elevation 1

A duplicate of this application has also been submitted for a non-material amendment under Section 96a to revise the extant permission. That application was submitted under reference. **PP-05953469**

### **Conclusion**

The application has been submitted online via the planning portal (**PP-05953484**).

We trust this information is sufficient for you to validate the application. However, if you do require any further information please do not hesitate to contact Gareth Fox or Anthony Brogan of this office.

Yours faithfully,

MONTAGU EVANS LLP

**MONTAGU EVANS LLP**