

THIS DRAWING IS PROTECTED BY COPYRIGHT AND MUST NOT BE COPIED OR REPRODUCED WITHOUT THE WRITTEN CONSENT OF CHRIS DYSON ARCHITECTS LIMITED. NO DIMENSIONS ARE TO BE SCALED FROM THIS DRAWING. ALL DIMENSIONS AND LEVELS TO BE CHECKED ON SITE. NORTH POINTS SHOWN ARE INDICATIVE.

SITE SPECIFIC HAZARDS

IN ACCORDANCE WITH THE REQUIREMENTS OF THE CONSTRUCTION (CANNED) REGULATIONS 2007 THE FOLLOWING SIGNIFICANT RESIDUAL HAZARDS HAVE NOT BEEN DISREGARDED OUT OF THIS PROJECT AND MUST BE TAKEN INTO CONSIDERATION BY CONTRACTORS PLANNING TO UNDERTAKE THE WORKS SHOWN ON THIS DRAWING:

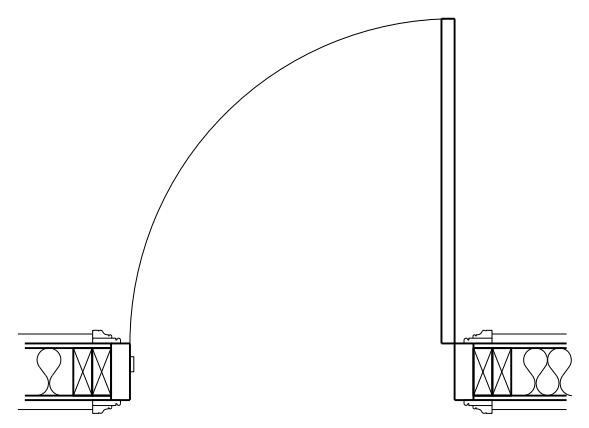
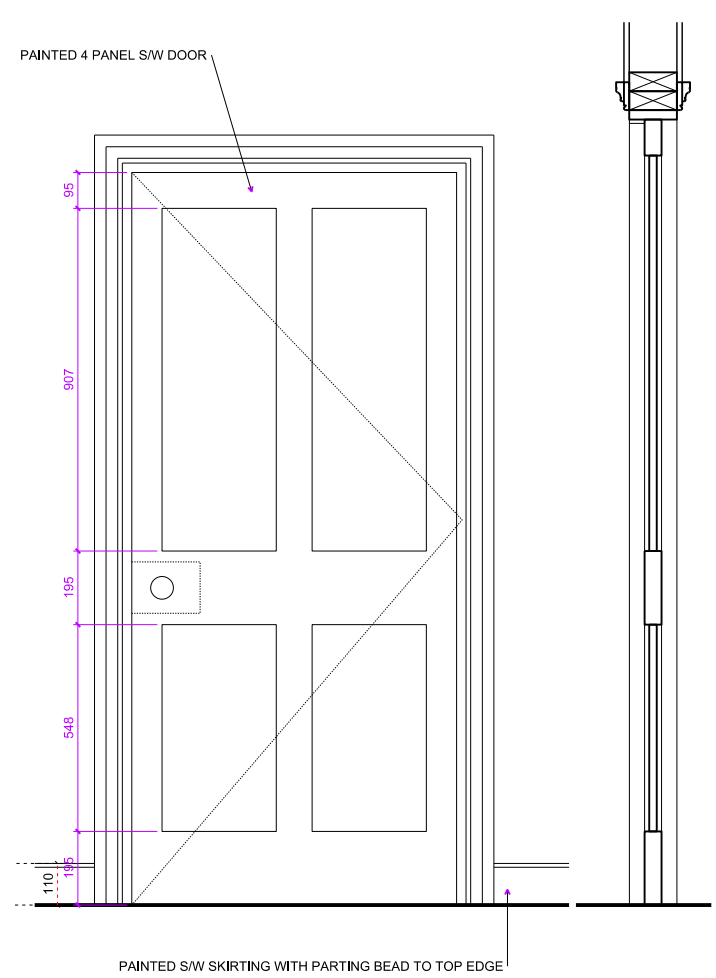
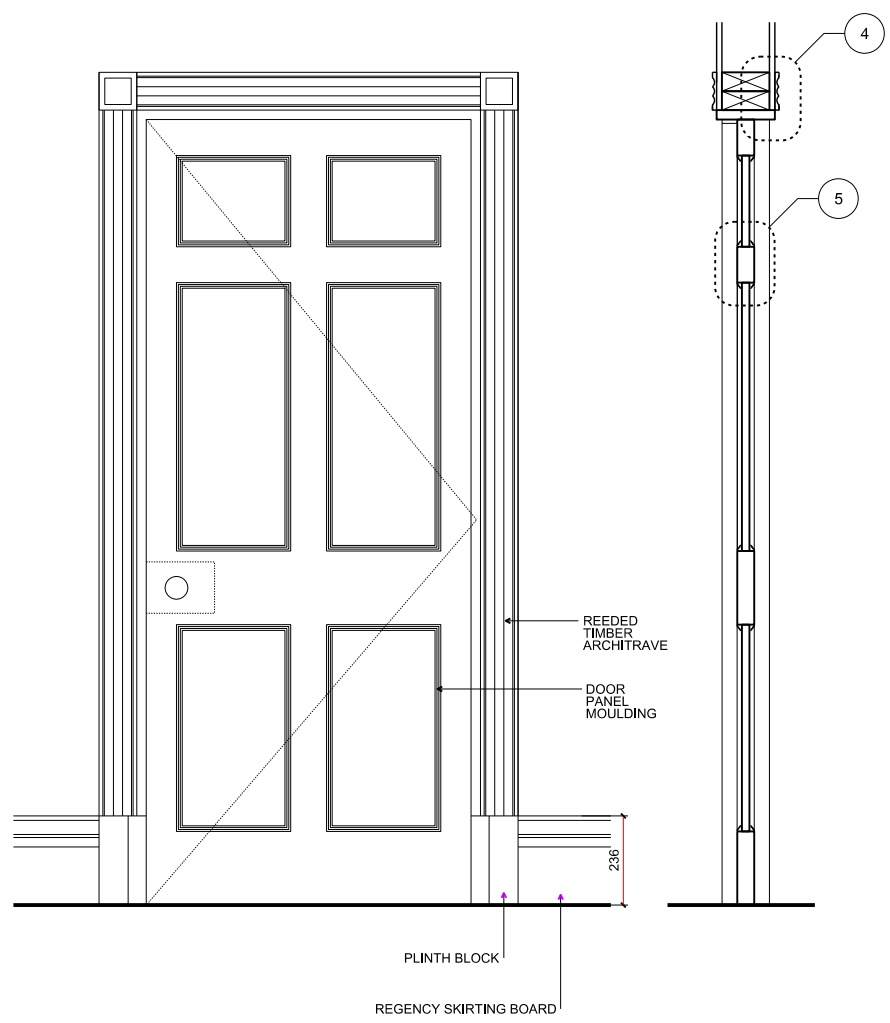
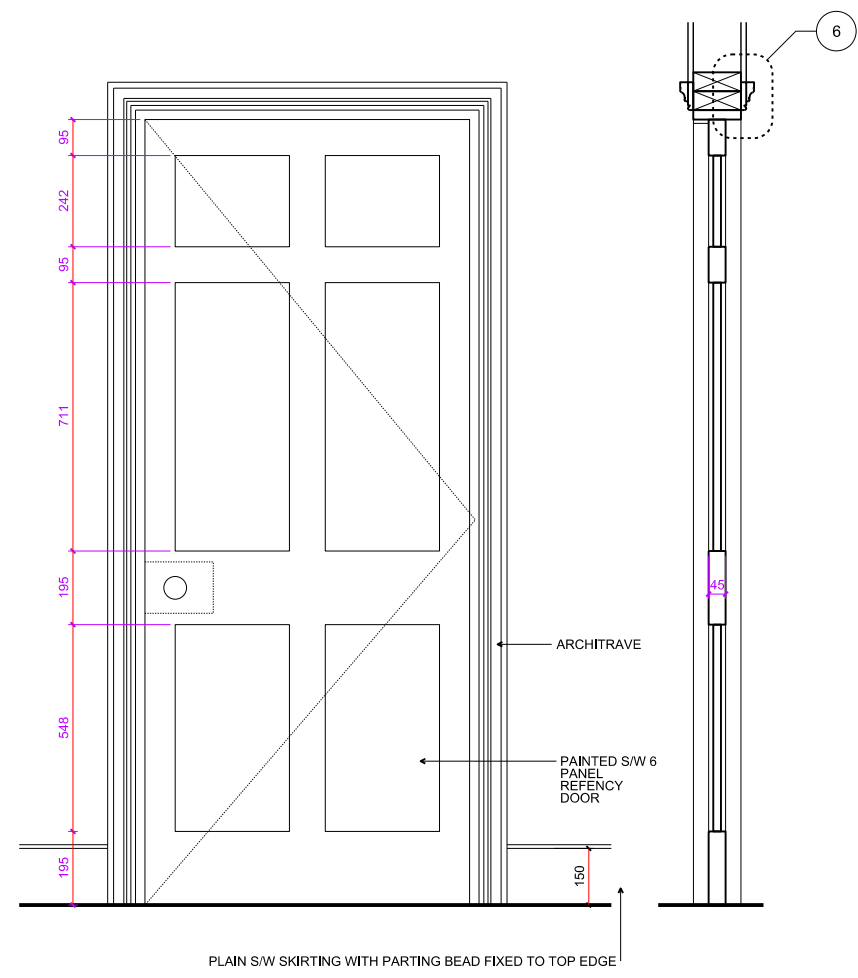

01 PROPOSED DOOR - SECOND FLOOR

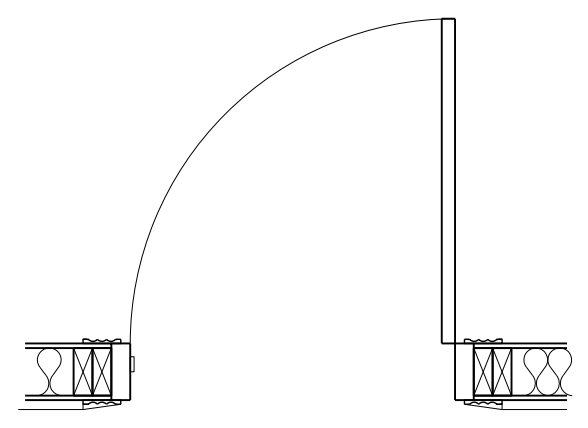
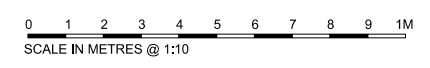

02 PROPOSED DOOR - GROUND AND FIRST FLOOR

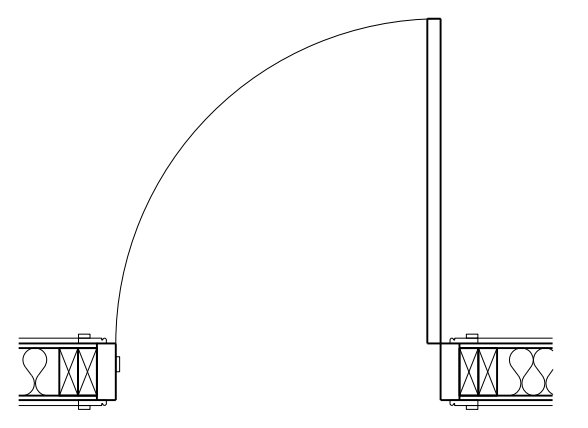

03 PROPOSED DOOR - BASEMENT

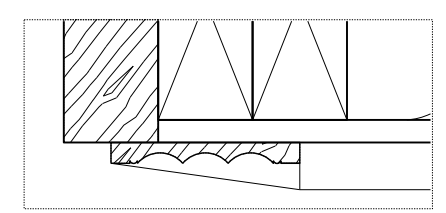

04 1:2 TYPICAL REEGED ARCHITRAVE

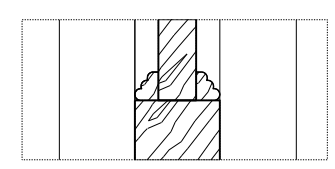

05 1:2 TYPICAL DOOR MULDING

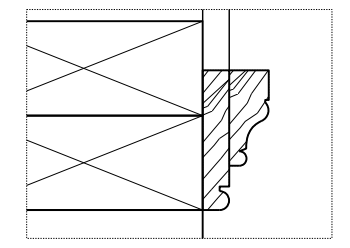

06 1:2 TYPICAL STANDARD ARCHITRAVE

01	03.04.17	PROFILES ADDED	-
00	30.03.17	PLANNING	-
REV	DATE	NOTES	INIT.
PROJECT			
51 SIDMOUTH STREET			
WC1H 8JX			
DRAWING TITLE			
PROPOSED INTERNAL DOOR TYPES			
STATUS PLANNING			
DATE	DRAWN	CHECK	SCALE @ A1 1:10
JAN 17	-	GP	SCALE @ A3 1:20
PROJECT NUMBER	UNIT / BLOCK	CL / SP / B CODE	TYPE & REVISION NUMBER LETTER
0354	A	1400	01