

Existing TV elevations 1:5

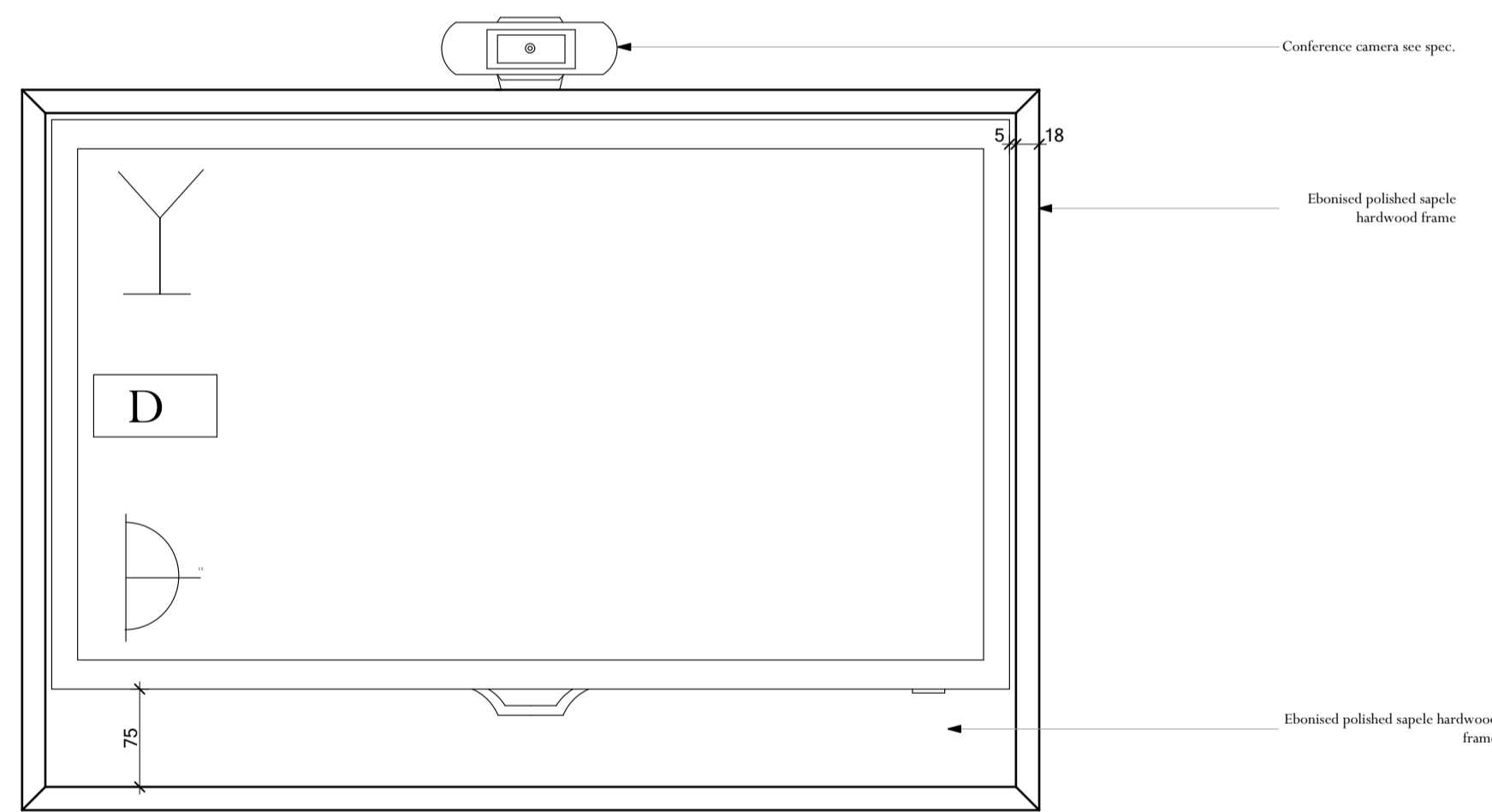

TV case elevations 1:5

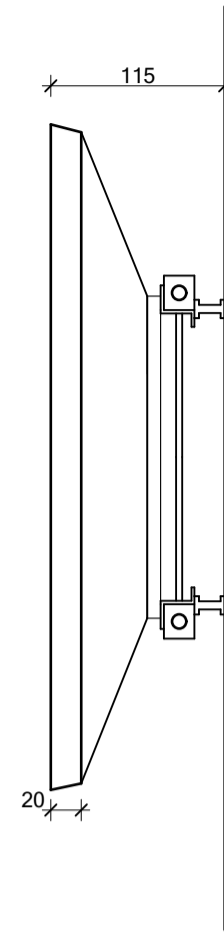
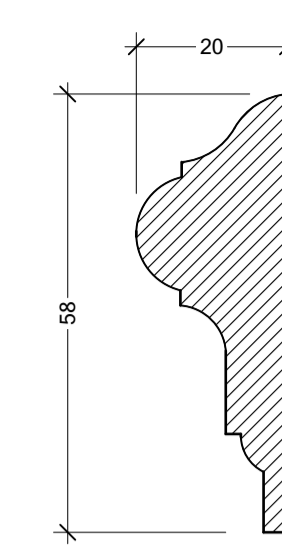
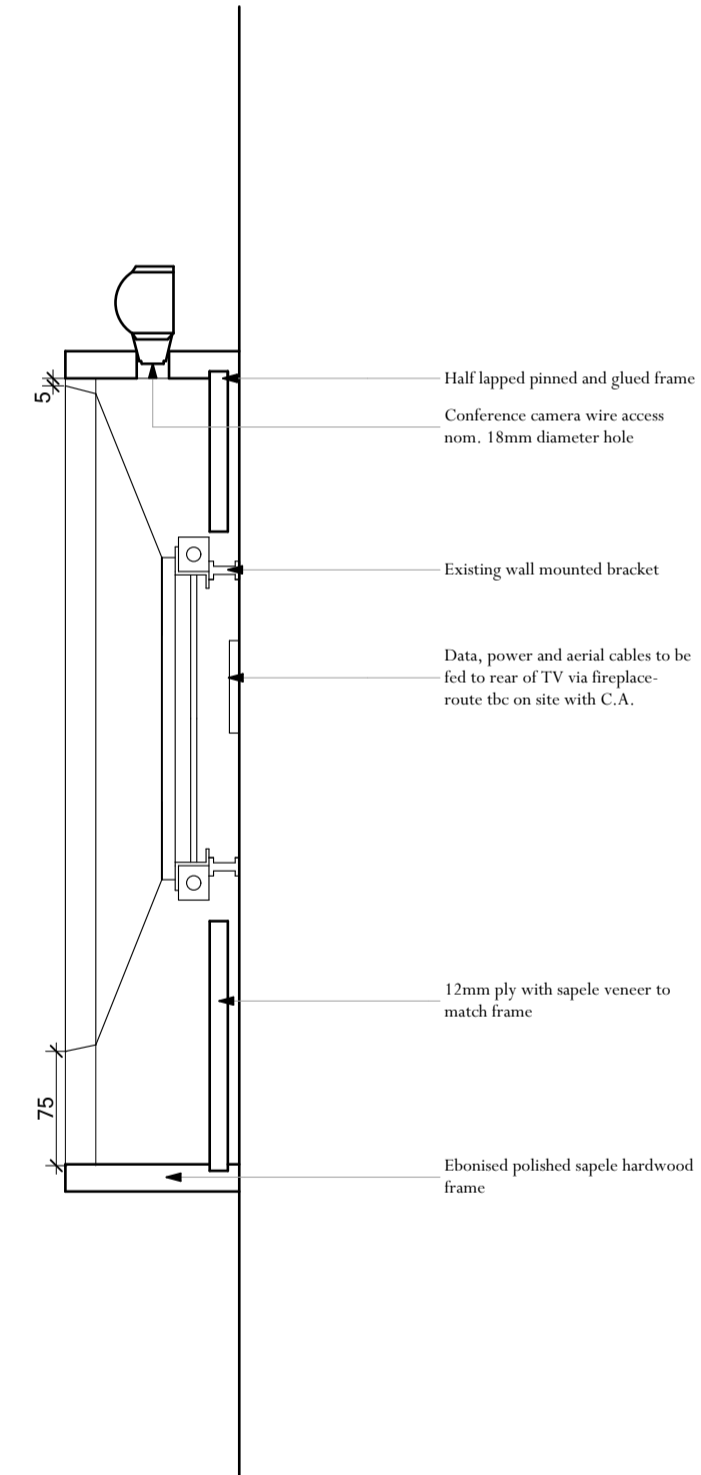

Dado Type 1: Studio:1



Entrance door
Survey Dado Rail Type 1 here

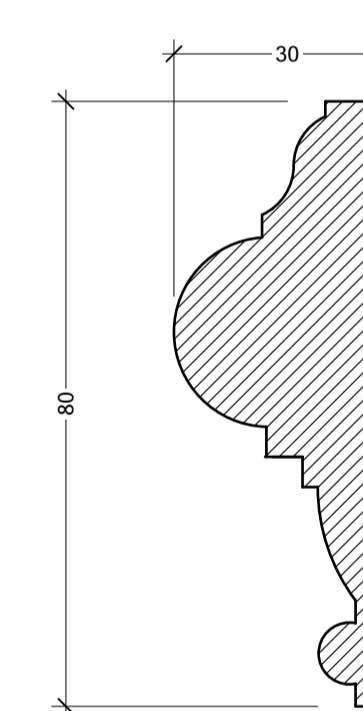

Dado Type 2: Meeting Room 1:1



Window adjacent to meeting room jib door

Survey Dado Rail Type 2 here

Adjacent Properties and Boundaries are shown for illustrative purposes only and have not been surveyed unless otherwise stated.
 All areas shown are approximate and should be verified before forming the basis of a decision.
 Do not scale other than for Planning Application purposes.
 All dimensions must be checked by the contractor before commencing work on site.
 No deviation from this drawing will be permitted without the prior written consent of the Architect.
 The copyright of this drawing remains with the Architect and may not be reproduced in any form without prior written consent.
 Ground Floor Slabs, Foundations, Sub-Structures, etc. All work below ground level is shown provisionally. Inspection of ground condition is essential prior to work commencing.
 Reassessment is essential when the ground conditions are apparent, and redesign may be necessary in the light of soil conditions found. The responsibility for establishing the soil and sub-soil conditions rests with the contractor.

NOTE:
 - Profiles shown are indicative. Contractor to survey dado rails in the locations shown on the photos

A 03.02.17 Issued for tender
 Rev Date Description Initials

PROJECT 6 Queen Square Refurbishment
 London

TITLE: Proposed Meeting Room TV Case

SCALE: 1:1/ 1:5 @ A1

DATE: Jan. 2017

DRAWING No: 5861 23 A

DRAWN BY: AH / LM

ADAM ARCHITECTURE

OLD HYDE HOUSE, 75 HYDE STREET
 WINCHESTER, HAMPSHIRE, SO23 7DW
 TELEPHONE: 01962 843843 FACSIMILE: 01962 843303
 www.adamarchitecture.com contact@adamarchitecture.com

LONDON OFFICE: 6 QUEEN SQUARE, WC1N 3AT
 TELEPHONE: 020 7841 0140 FACSIMILE: 01962 843303
 ADAM ARCHITECTURE IS A TRADING NAME OF ADAM ARCHITECTURE LIMITED