

ISOMETRIC VIEW
GLASS RETURN

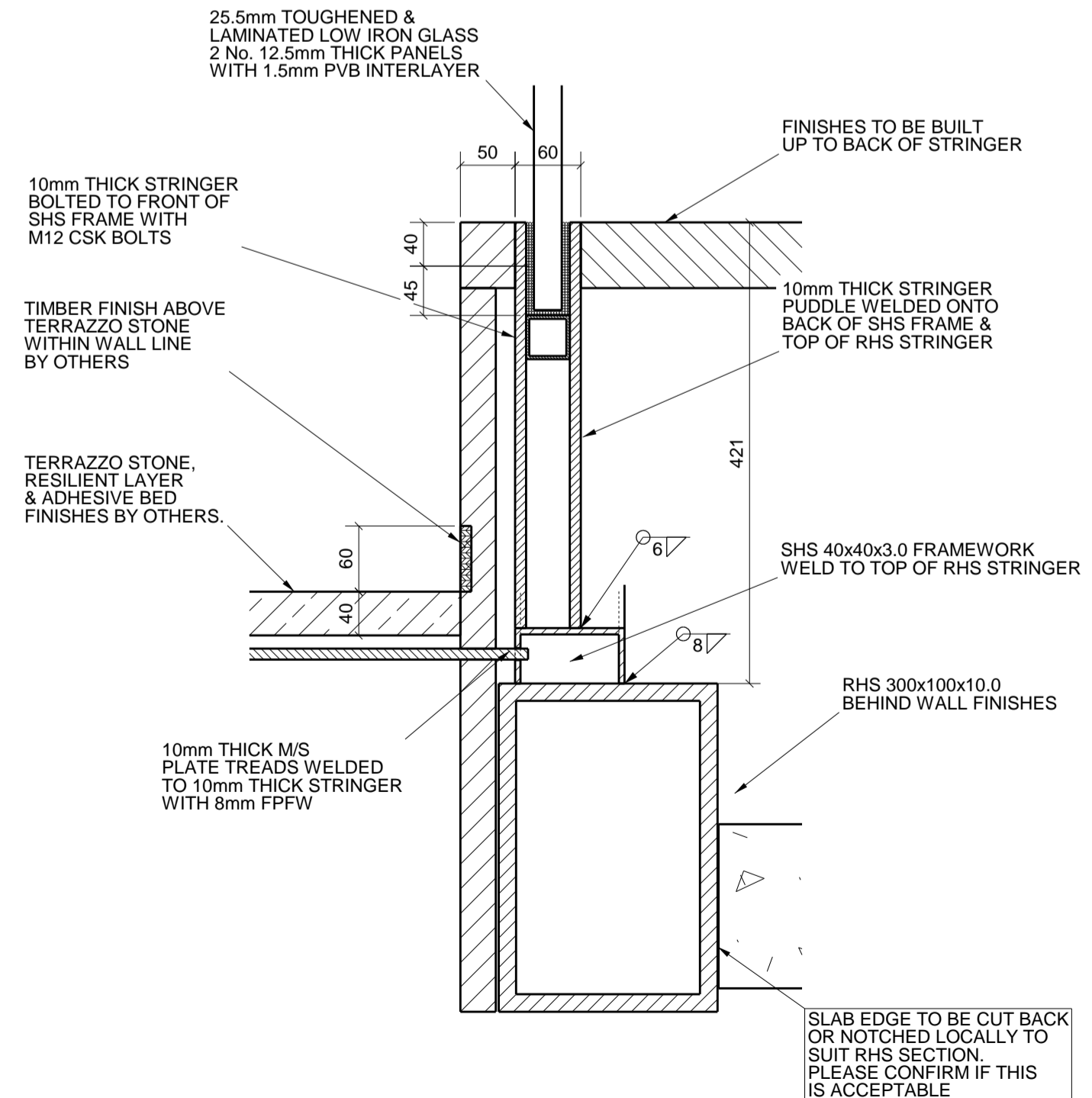

E1 - E1

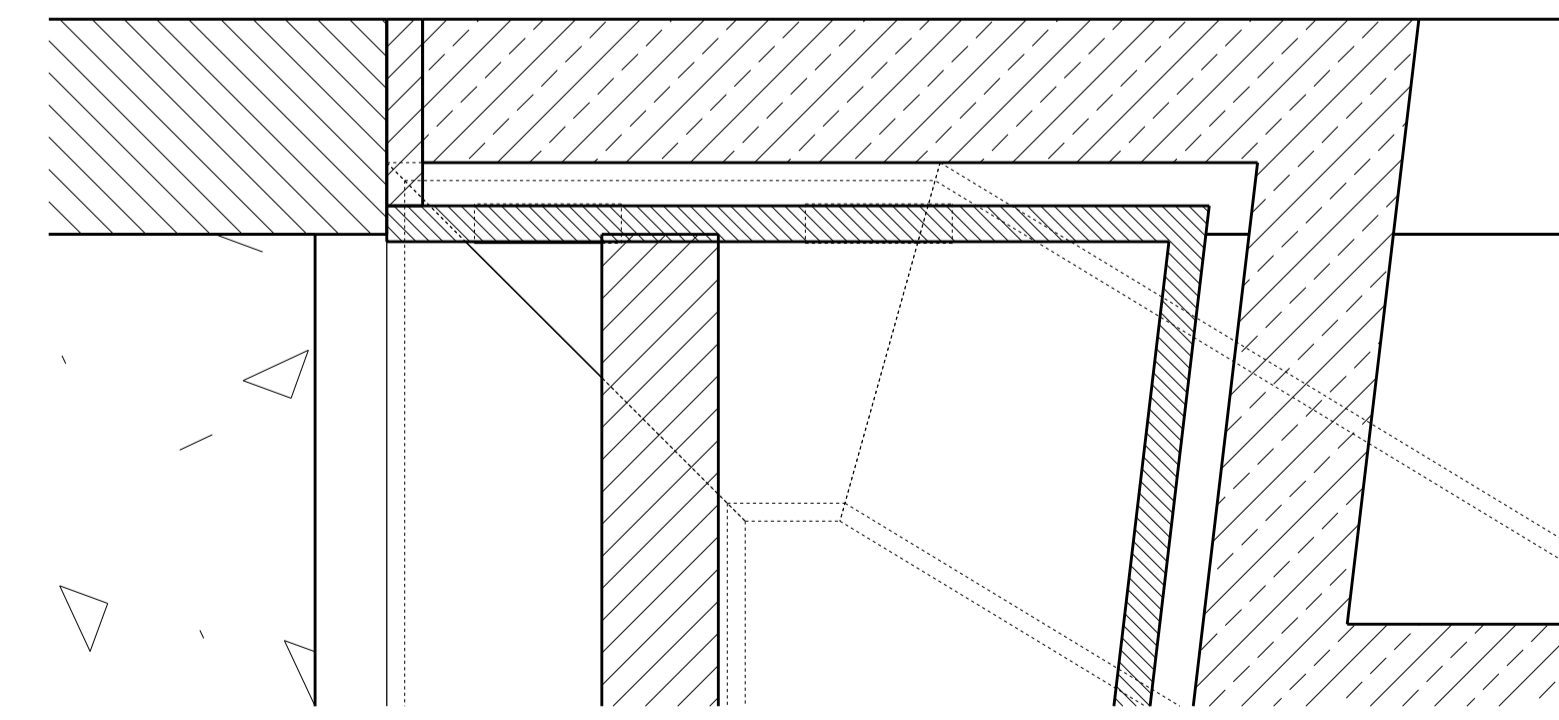

Safety, Health and Environment Information
In addition to the hazards/risks normally associated with the types of work detailed on this drawing, note the following information:

Construction	NO UNUSUAL RISK
Dismantling/ Demolition (Future)	NO UNUSUAL RISK

For information relating to Use, Cleaning and Maintenance see Health and Safety File. It is assumed that all works will be carried out by a competent contractor working, where appropriate, to an approved method statement.

GENERAL NOTES:
STEEL BEAMS GRADE S355J0
ALL STEEL CONNECTIONS GRADE S275 U.N.O
ALL BOLTS GRADE 8.8
FOR STRUCTURAL CHECKING REFER TO:
E101-34-CPW-XX-CALC-024

FINISH:-
SHOT BLAST CLEAN SA2.5 & FACTORY SPRAYED:
- INITIAL COAT: INTERCURE 200 OR SIMILAR PRIMER RECOMMENDED BY MANUFACTURER – (100 MICRONS MIN. DFT)
OR AS STRUCTURAL ENGINEER'S SPECIFICATION FOR CORROSION PROTECTION.
- COLOUR: GREY.
- FINISHING COAT: INTERGARD 400 - MICACEOUS IRON OXIDE FINISH. (100 MICRONS MIN. DFT)
- COLOUR: DARK GREY

THIS DRAWING PREPARED IN ACCORDANCE WITH RMA DRGS:
600-14025-CPL_C1
600-14026-CPL_C1
600-14153-CPH_C1
600-14154-CPH_C2
600-42100-CPL_C1
600-43815-CPL_C1
600-43816-CPL_C1
600-43817-CPL_C1
600-43818-CPL_C1

THIS DRAWING PREPARED IN ACCORDANCE WITH PF DRGS:
A12504-VAA-201-S
A12504-VAA-202-R
A12504-VAA-214-H
A12504-VAA-240-B

0	BUILDING CONTROL APPROVAL	JS	17-03-17
Rev	Revision Details	Check	Date

Client:
Almacantar

Contractor:
MULTIPLEX

Lee Warren Fabrication and Design Ltd.
Units 6-9 Silverdale Road Industrial Estate,
Silverdale Road, Hayes, Middlesex
UB3 3BL, United Kingdom
CE
14
0086-CPR-613428



Project:
CENTRE POINT LONDON

Title:
STAIRCASE 2
GLASS RETURN AT TOP OF STAIR
ISOMETRIC, SECTIONS & DETAIL

Status: BUILDING CONTROL	Date: 17-03-17	Scale: 1:2, 1:5, 1:10			
Job No.: 1689-077	Drawn by: JS [DDM]	Checked by:			
Origin	CISFB Code	Bldg Code	Level	Series	Revision
E101	34	CPL	XX	342	0