

01 Gate 01

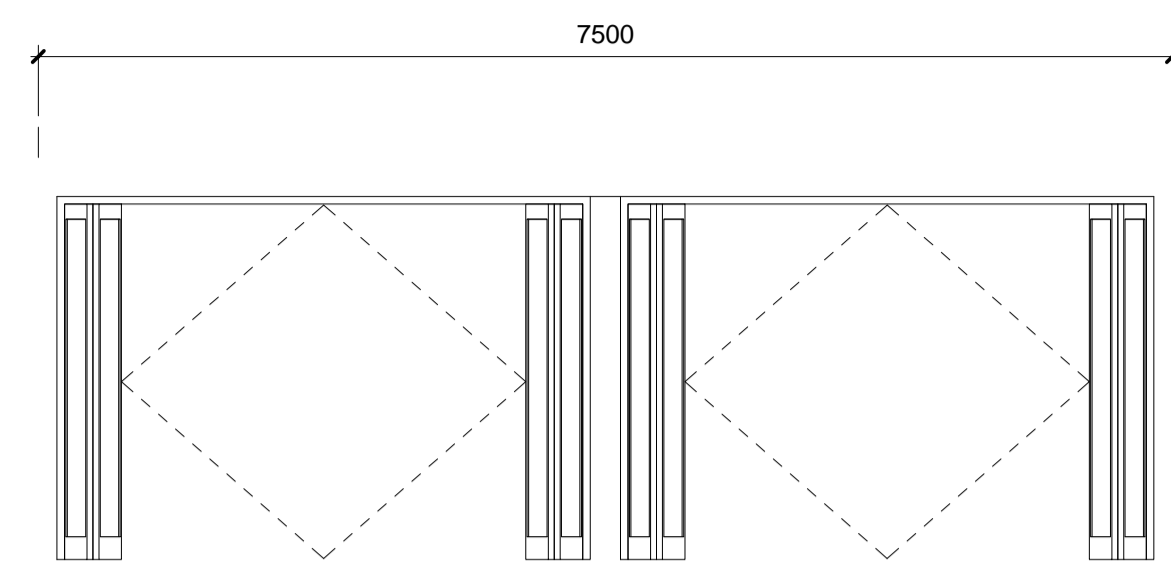

02 Gate A1

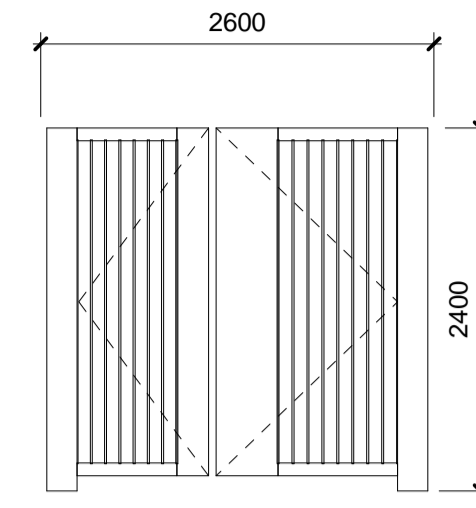

03 Gate A2

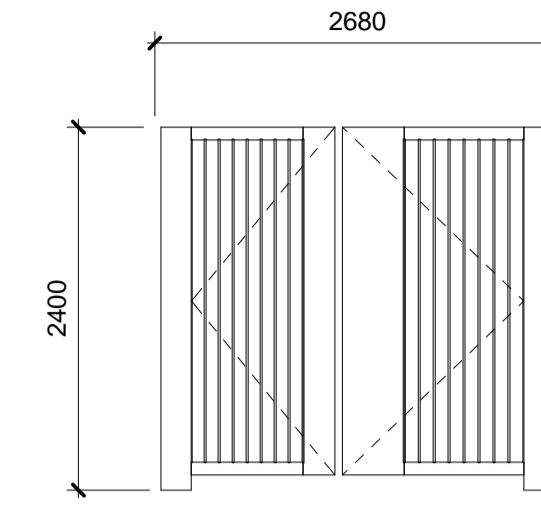

04 Gate 02

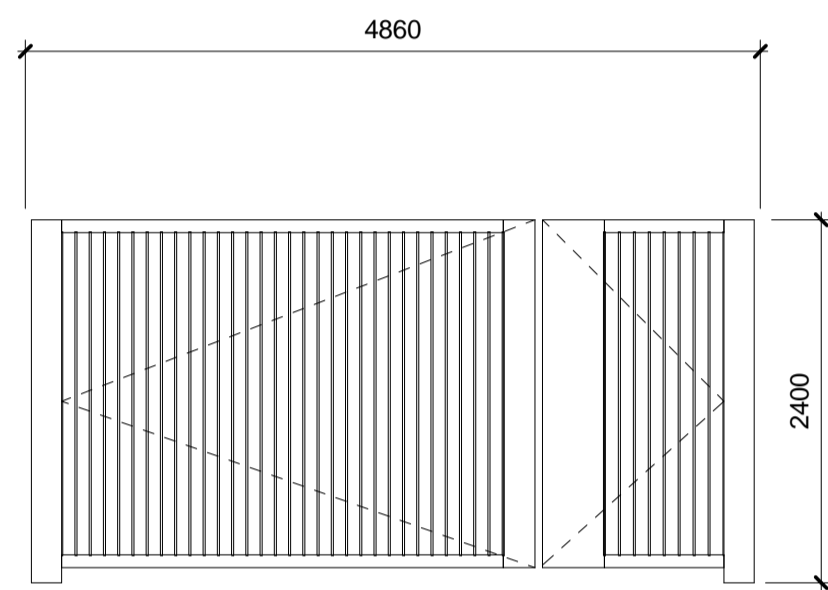

05 Gate 03

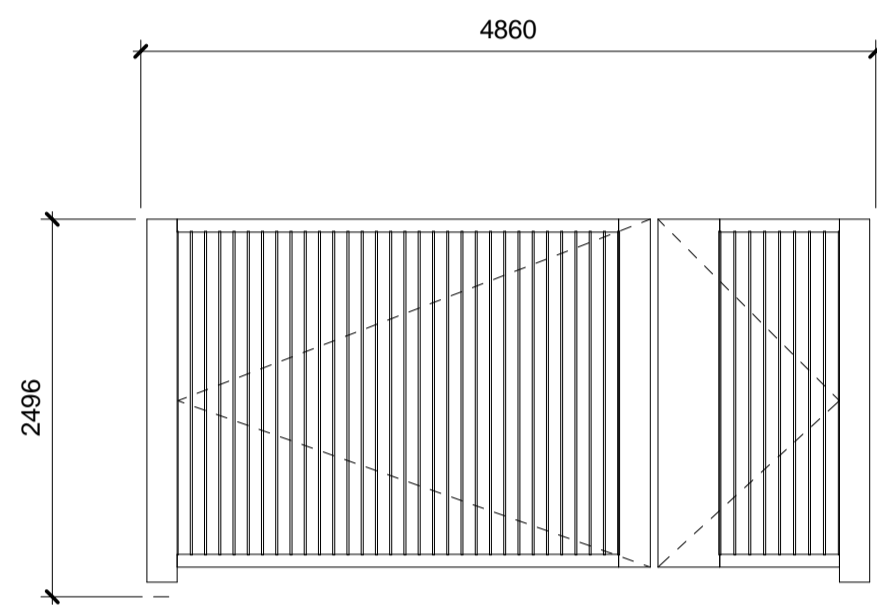

06 Gate 04

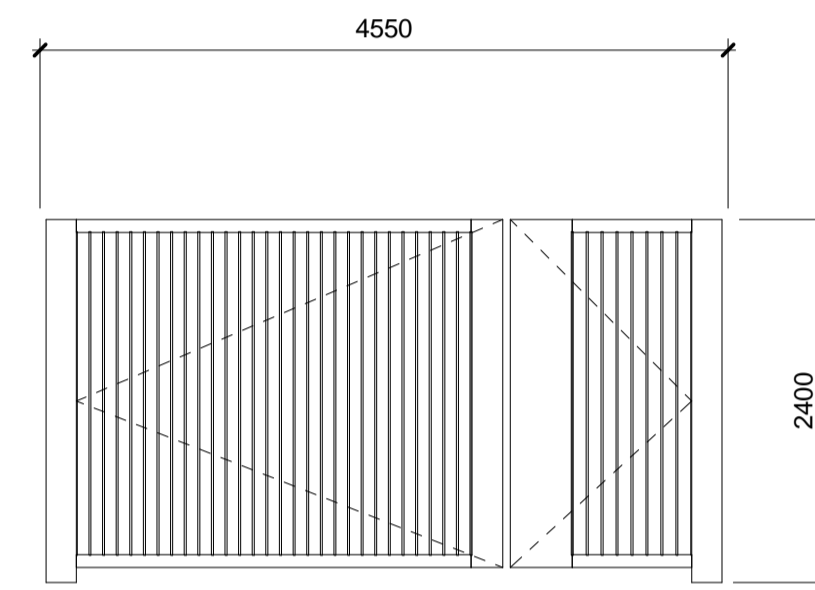

07 Gate 05

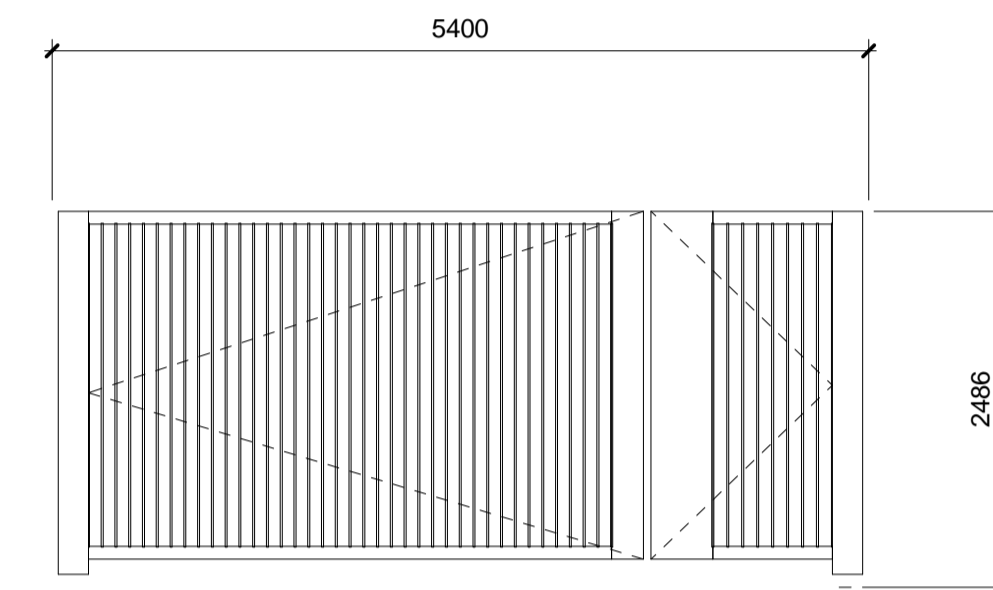

08 Gate 06

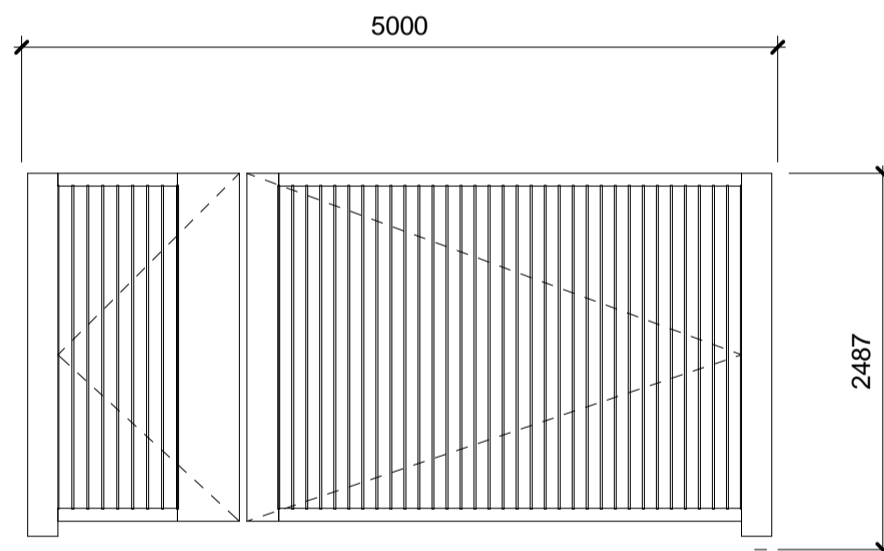

09 Gate 08

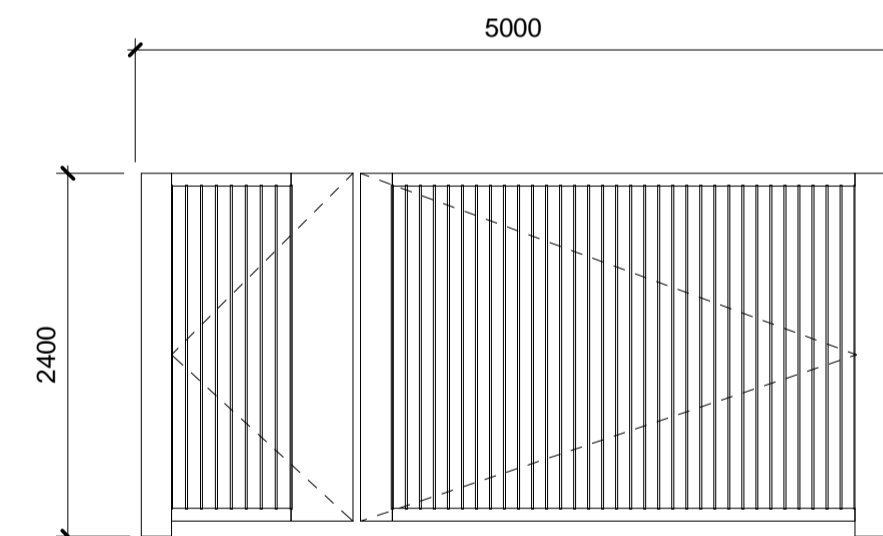

10 Gate 09

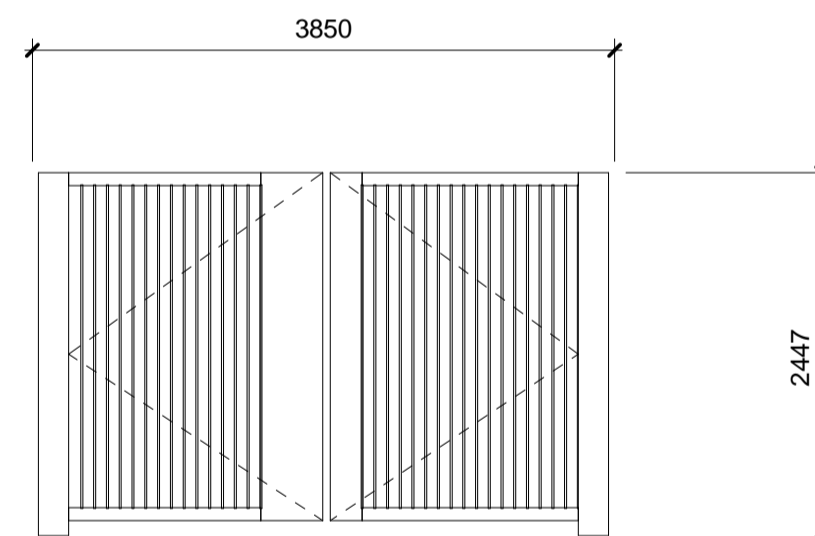

11 Gate 10

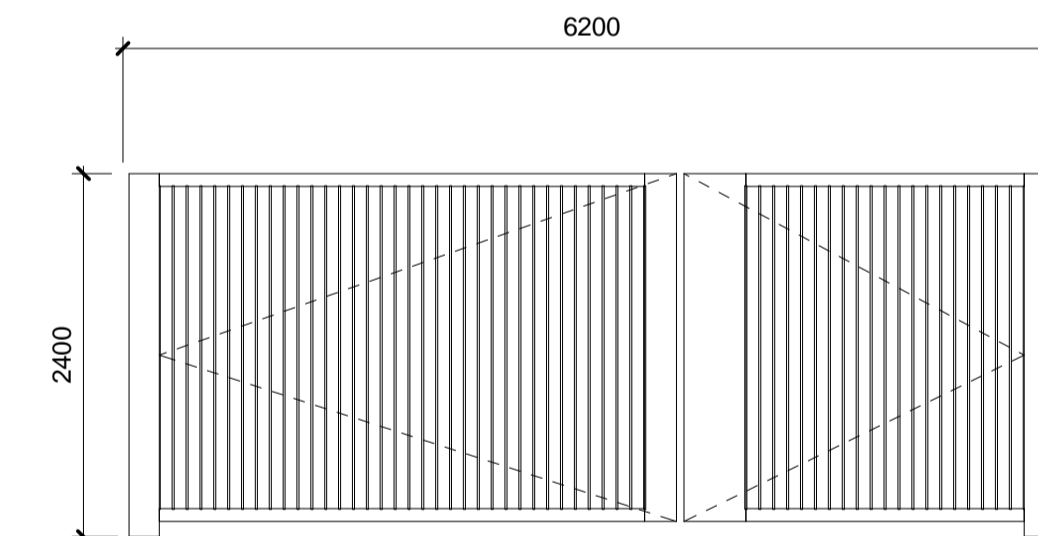

12 Gate 11

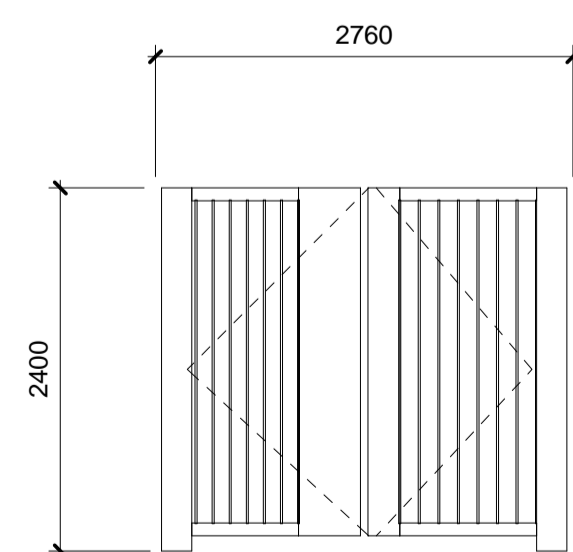

13 Gate 16

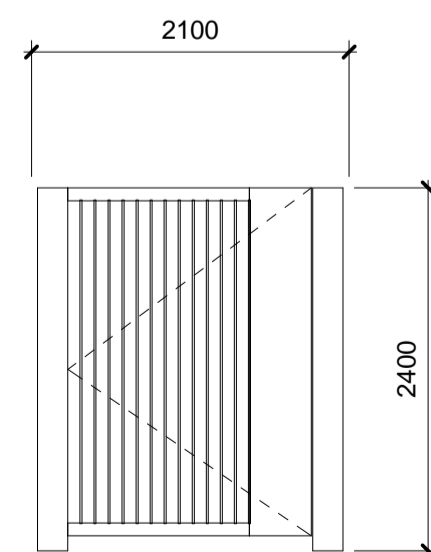

14 Gate 17

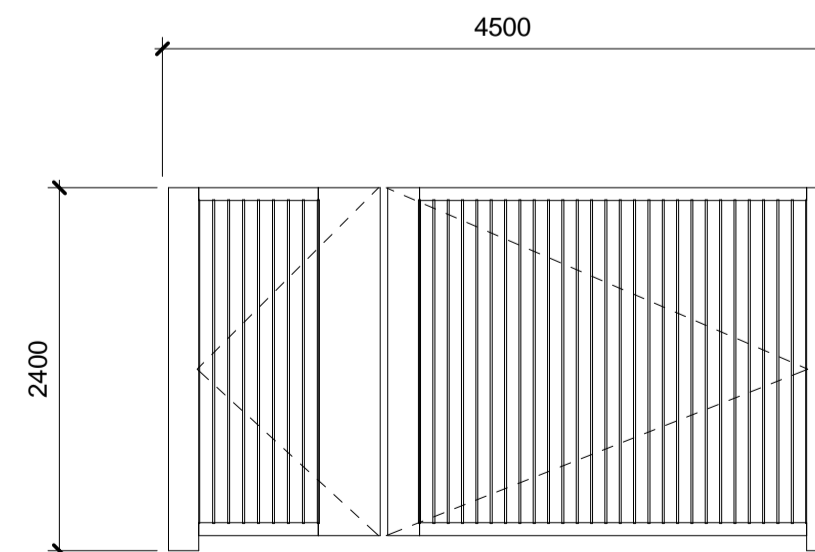

15 Gate 20

KEY

T03	18/12/15	Issued for ERs
T02	26/06/15	Stage E Issue
T01	30/01/15	For First Stage Tender

REV	DATE	DESCRIPTION

CONSULTANTS

CLIENT:	Stanley Sidings
CONTRACTOR:	Mace
STRUCTURAL ENGINEER:	Walsh Group
MECHANICAL ENGINEER:	Hoare Lea
COST CONSULTANT:	Gardiner & Theobald
PROJECT MANAGER:	Gardiner & Theobald
ACOUSTIC CONSULTANT:	Arup
TRANSPORT CONSULTANT:	Arup
PLANNING CONSULTANT:	Gerald Eve
LANDSCAPE ARCHITECT:	Fabrik
CDM CO-ORDINATOR:	MSA Safety

NOTE

- Do not scale from this drawing.
- All dimensions to be checked on site by the contractor and such dimensions to be his responsibility. Report all drawing errors, omissions and discrepancies to the architect.
- This document may be issued in an uncontrolled CAD format to enable others to use it as background information to make alterations and/or additions. In that instance the file will be accompanied by a PDF version. It is for those making such alterations and additions to ensure that they make use of current background information.
- AHMM Ltd accepts no liability for any such alterations or additions to the background information or arising out of changes to background information which occur prior to alterations of additions being made.

Note

All gates to meet accessibility requirements for widths and opening force  
 All gates within residential circulation routes to be provided with fob access and handles to permit free escape from inside  
 Handles / mechanisms etc to be suitable for use by people with limited strength and dexterity  
 Opening / closing force to be within 30N or gate will require automatic opening  
 All door casing assemblies to be tamper proof and external hinges to be provided with welded cover plates to prevent climbing  
 Emergency escape sign and statutory signage to be provided to gates within door casing zone  
 Gate lettering - design TBC  
 The height of the gates will be reviewed during Stage F to ensure coordination with transom heights of adjacent buildings

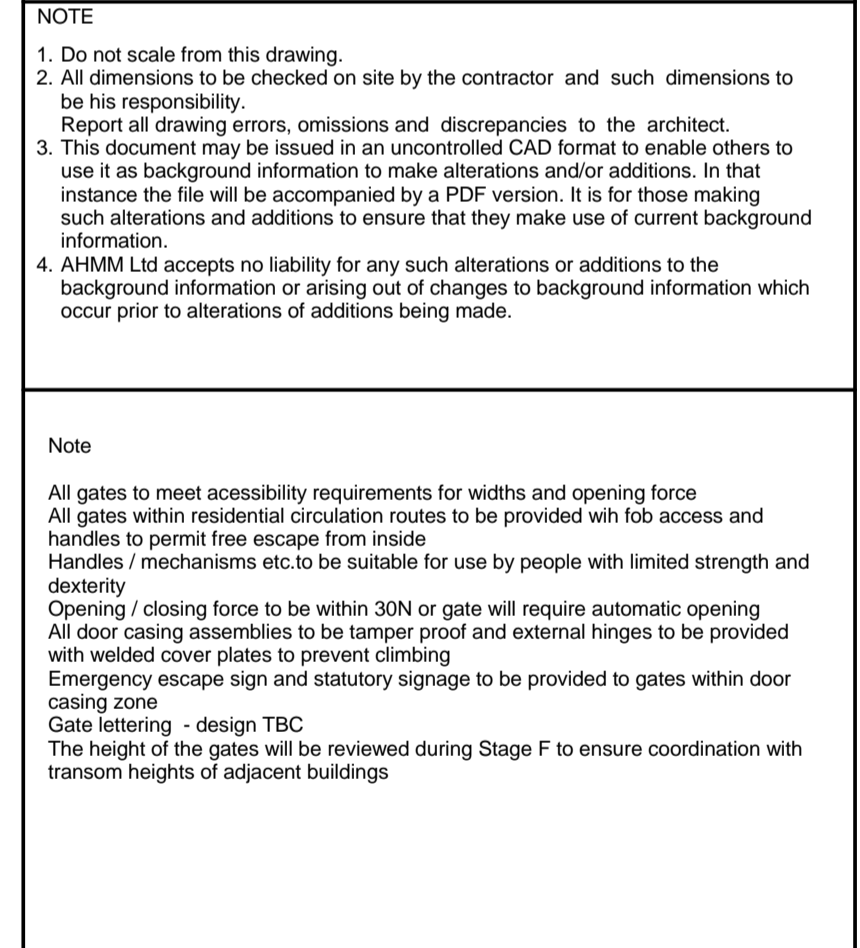

LOCATION

**ALLFORD HALL MONAGHAN MORRIS**  
 ARCHITECTS Ltd  
 5-23 OLD STREET, LONDON, EC1V 9HL  
 TEL 020 7251 5261 FAX 020 7251 5123 WEB WWW.AHMM.CO.UK

job title  
**Camden Lock Village**  
 drawing title / location  
**Gates Scope Drawing**

drawn by	checked	scale	status
JM	AH	1 : 50 @ A1	ERs Issue
project	drawing no.	revision	
14045	MX_(67)_1100	T03	