

1100 ltr Wheelie Bin Specification Sheet

Features

- Manufactured and tested to EN840 - DIN30700. (EN840 is the Europe wide standard for emptying interoperability and handling safety).
- Extra strength comb lift bar.
- Made from HDPE (High –density Polyethylene) for extra strength and life.
- Full thickness “flat body” design (Some other bins, with “fluted bodies” that are much thinner, won’t last as long).
- Maximum strength additives for resistance to UV, cold, heat and chemicals. (No corners cut).
- High strength Trunnions (Din Lifting Side Lugs) supplied as standard.
- Certified compliant with EU the noise protection Directive.
- 100% recyclable at end of life.



Specifications

- Weights:- Rated maximum load 450kg. Dead weight 58kg
- Dimensions:-

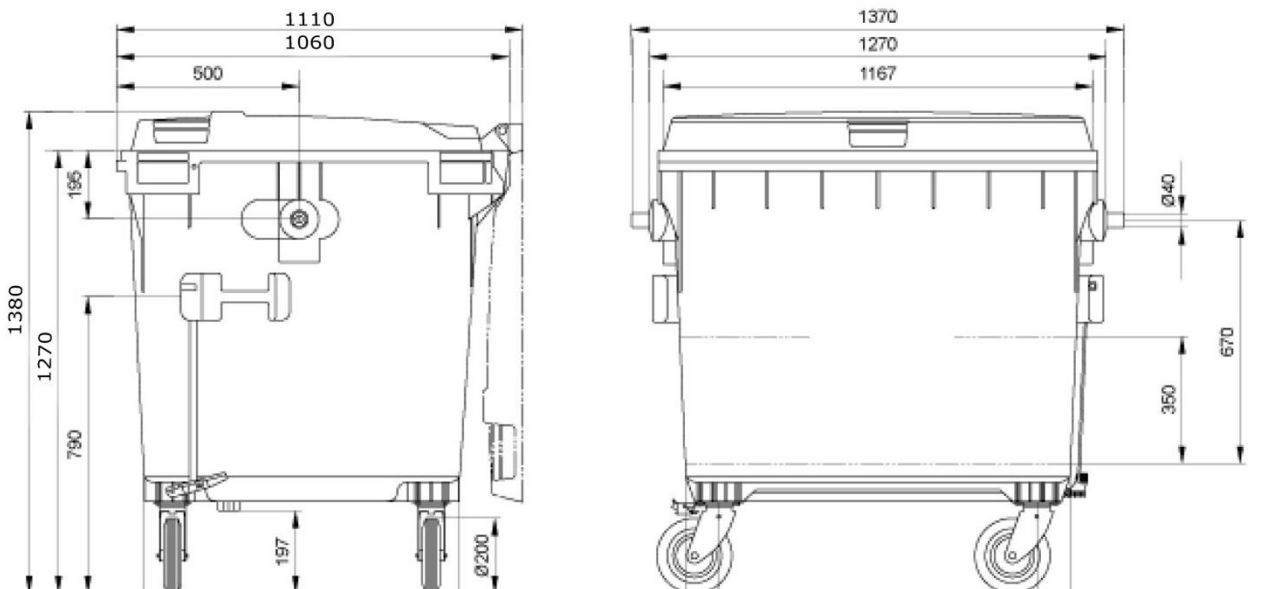

- **Standard Colours:-**
 Other colours are available for orders of 100+ units

Antracite Grey R7016
Reseda Green R6011
Traffic Red R3020
Sky Blue R5015
Zinc Yellow R1018