

74a

76

REVISIONS

Rev.	Date	By
- Issue for Planning	12.08.16	MG
- Amended based on Planners Comments	19.12.16	MG

- Internal access routes to the Refuse Area
- Goods Lift
- Refuse Room
- Collection Point
- Refuse Vehicle access routes to Refuse Area

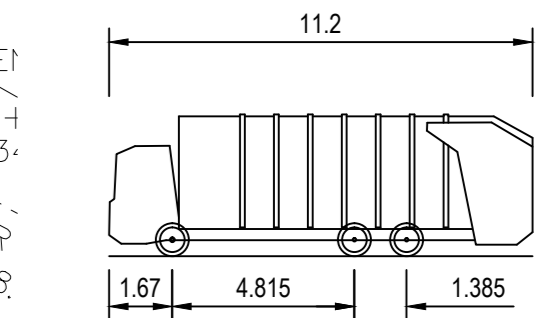

PHOENIX 2 DUO (P2-15W WITH ELITE 6 x 4 CHASSIS)
 OVERALL LENGTH 11.200m
 OVERALL WIDTH 2.330m
 OVERALL BODY HEIGHT 3.751m
 MIN BODY GROUND CLEARANCE 0.304m
 TRACK WIDTH 2.500m
 LOCK TO LOCK TIME 4.00s
 KERB TO KERB TURNING RADIUS 9.500m

AUTOTRACK VEHICLE DETAILS

CONSTRUCTION ISSUE

ALL DIMENSIONS TO BE CHECKED ON SITE
 WORK TO FIGURED DIMENSIONS ONLY
 REPORT DISCREPANCIES TO THE ARCHITECT
 AT ONCE BEFORE PROCEEDING

Contemporary Design Solutions

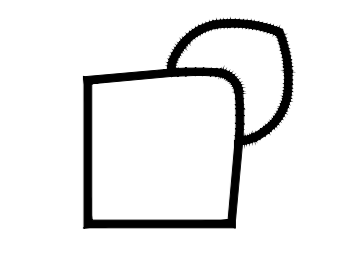

46 Great Marlborough Street
 London
 W1F 7JW
 Telephone: 020 7494 9000 Fax: 020 7494 4944

Client

HALLMARK PROPERTY GROUP

Project Title

B&WAREHOUSE & STUDENT ACCOMMODATION
65-69 HOLMES ROAD

Drawing Title

REFUSE SERVICING PLAN

Scale 1: 100@A0 NTS@A3 Date DEC 2016
 Drawn MG Checked CT
 Drawing No. Rev.

131050 (CL) 100
 A

CAD plot date:

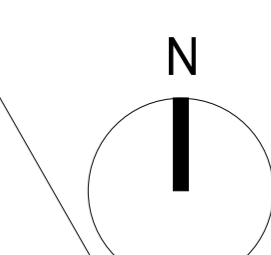

WORKS

