

This drawing is copyright and may not be copied or reproduced without the written consent of this practice

The contractor is responsible for setting out and must check all levels and dimensions prior to work being put in hand

This drawing should not be scaled. Only written dimensions are to be taken in respect of this project

The Architect is to be immediately notified of any suspect omissions or discrepancies

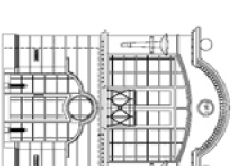

MILES BROE ARCHITECTURE LLP
CHARTERED ARCHITECTS AND PLANNING CONSULTANTS

Sussex Innovation Centre
Science Park Square, Falmer
Brighton, East Sussex, BN1 9SB
Telephone: 01273 625911
Fax: 01273 666381
www.milesbroearchitects.co.uk

CLIENT
THINKING OUTSIDE THE BOX

PROJECT
**CHANGE OF USE FROM 1NO.
PHONE BOX TO 1NO. NEW MOBILE
PHONE REPAIR SHOP**

**@ OUTSIDE 35 HAMPSTEAD HIGH
STREET, LONDON, NW3 1QE**

DRAWING
**PROPOSED DETAILED PLANS
ELEVATIONS OF LOVEPHONE
FITTINGS**

REV DATE COMMENT

REV BY

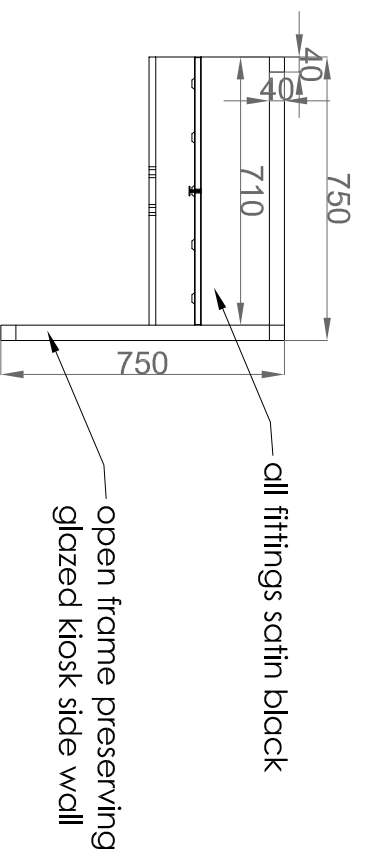
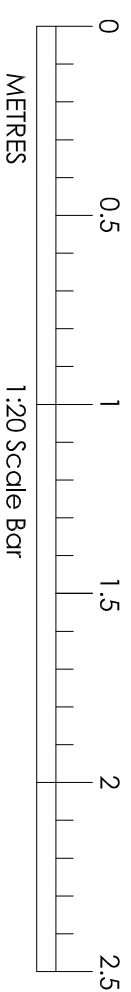

**Proposed Plan
@ 1 : 20**

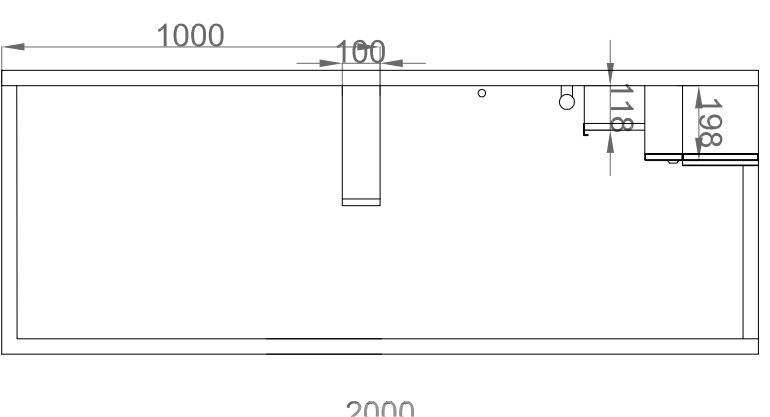

**Proposed Side
Elevation of Unit @ 1 : 20**

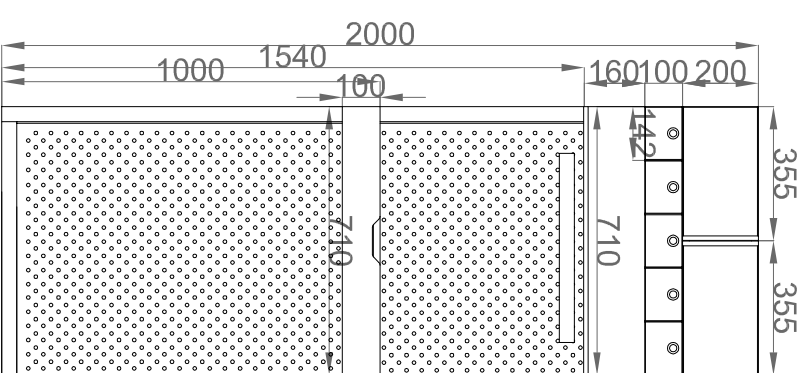

**Proposed Rear
Elevation of Unit @ 1 : 20**

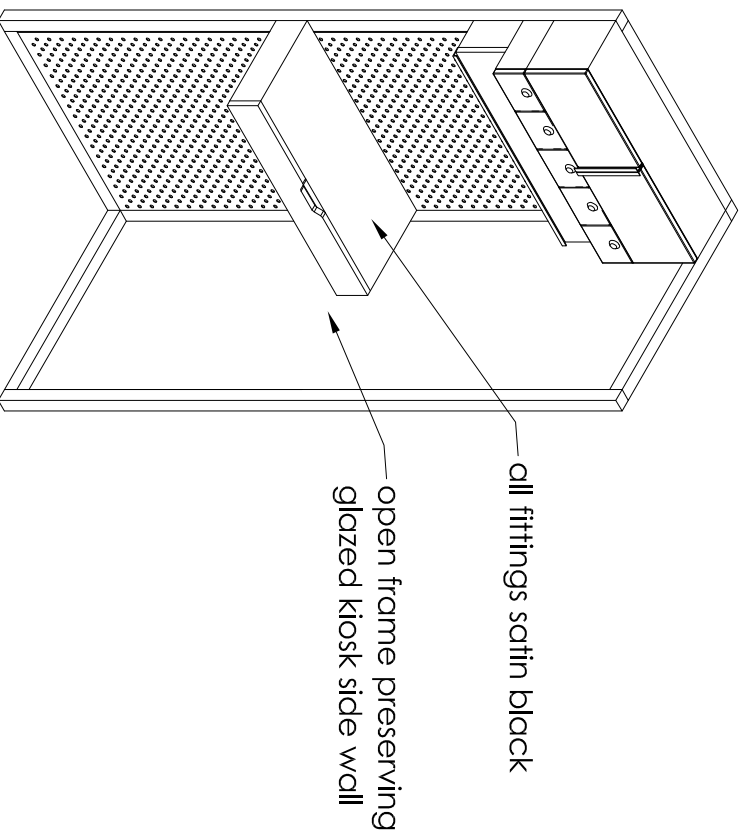

Proposed Axonometric of Unit @ 1 : 20

scale date drawn
1:20 @ A3 Feb 2017 FMB

job no drawing no revision
9232-16.2 PL03