

- GENERAL :**
1. ALL DIMENSIONS ARE IN MILLIMETRES UNLESS OTHERWISE NOTED.
 2. ALL LEVELS ARE IN METRES ABOVE ORDINANCE DATUM.
 3. ALL DIMENSIONS ARE TO BE CHECKED ON SITE PRIOR TO ANY WORKS BEING PUT IN HAND.
 4. THE CONTRACTOR IS RESPONSIBLE FOR THE STABILITY OF THE EXISTING STRUCTURE AT ALL TIMES DURING THE WORKS.
 5. THIS DRAWING IS TO BE READ IN CONJUNCTION WITH ALL OTHER CONTRACT DRAWINGS AND RELEVANT STRUCTURAL SPECIFICATIONS.
 6. FOR SETTING OUT OF WALLS AND FLOORS SEE ARCHITECTS DRAWINGS.
 7. ALL MATERIALS USED IN THE WORKS SHALL BE TO EUROCODES, BRITISH STANDARDS OR OTHER APPLICABLE SPECIFICATIONS.
 8. ALL WORK IS TO BE CARRIED OUT TO B.S. CODES OF PRACTICE AND IN ACCORDANCE WITH GOOD WORKMANSHIP PRACTICE.
 9. ALL PROPRIETARY MATERIALS USED IN THE WORKS ARE TO BE USED IN COMPLETE ACCORDANCE WITH THE MANUFACTURERS RECOMMENDATIONS.

- PILING - NOTES**
1. ALL WORK IS TO BE CARRIED OUT IN ACCORDANCE WITH THE INSTITUTION OF CIVIL ENGINEERS SPECIFICATION FOR PILING AND EMBEDDED RETAINING WALLS EXCEPT WHERE MODIFIED BY FOLLOWING NOTES.
 2. THE PILING CONTRACTOR SHALL DESIGN THE PILES IN ACCORDANCE WITH BS EN 1997-1 INCLUDING THE NATIONAL ANNEX.
 3. THE PILING CONTRACTOR SHALL BE DEEMED TO HAVE VISITED THE SITE AND TO HAVE MADE HIMSELF AWARE OF ALL LOCAL CONDITIONS WITH REGARDS TO LEVELS ACCESS AND ANY OTHER ITEMS WHICH MAY AFFECT HIS TENDER.
 4. THE PILING CONTRACTOR SHALL AGREE A PROGRAMME OF WORKS PRIOR TO COMMENCING ON SITE.
 5. THE PILING CONTRACTOR SHALL EXAMINE THE SITE INVESTIGATION REPORT AND SHALL DESIGN THE PILES IN ACCORDANCE WITH THE INFORMATION PROVIDED.
 6. THE PILING CONTRACTOR MUST INCLUDE IN HIS TENDER FOR CARRYING OUT THE WORKS IN THE CONDITIONS DESCRIBED IN THE INVESTIGATION REPORT.
 7. WHERE NO SITE INVESTIGATION REPORT EXISTS THE PILING CONTRACTOR SHALL OBTAIN SUFFICIENT SOIL INFORMATION AND DATA TO DESIGN AND INSTALL THE PILES.
 8. THE PRINCIPAL CONTRACTOR IS RESPONSIBLE FOR ALL THE SETTING OUT.
 9. REINFORCEMENT SHALL BE LEFT PROTRUDING 600mm ABOVE THE PILE CUT OFF LEVEL.
 10. THE PILE HEADS SHALL BE CONSTRUCTED TO AT LEAST 50mm BUT NO LESS THAN 300mm ABOVE THE CUT OFF LEVELS, TO BE SUPPLIED BY CONTRACTOR/CLIENT.
 11. THE PILING CONTRACTOR SHALL KEEP A FULL AND COMPREHENSIVE RECORD OF ALL WORK AS PILING PROGRESSES.
 - FIVE CUBES SHALL BE CAST FOR EVERY 10 PILES
 - 2 TO BE CRUSHED FOR 7 DAYS
 - 2 TO BE CRUSHED FOR 28 DAYS
 - 1 SPARE.
 13. THE MAXIMUM PERMISSIBLE DEVIATION FROM THE INDICATED SETTING OUT POSITION IS 75mm.
 14. THE MAXIMUM PERMISSIBLE DEVIATION FROM VERTICAL IS 1 IN 75.
 15. REINFORCEMENT SHALL BE IN ACCORDANCE WITH BS 4449 AND SHALL BE CUT AND BENT IN ACCORDANCE WITH BS 8666.

- CONCRETE :**
1. CONCRETE MIXES IN ACCORDANCE WITH B.S.8500-1:-
 - PILES C32/40 DS-1
 - PILE CAP C32/40
 - BLINDING C8/10
 3. BLINDING TO BE 50mm THICK BENEATH ALL AREAS OF CONCRETE.
 4. COVER TO BE 50mm UNO.
 5. ALL MESH TO HAVE 400mm MINIMUM LAPS BETWEEN SHEETS.

PILE PLAN SCALE 1:50

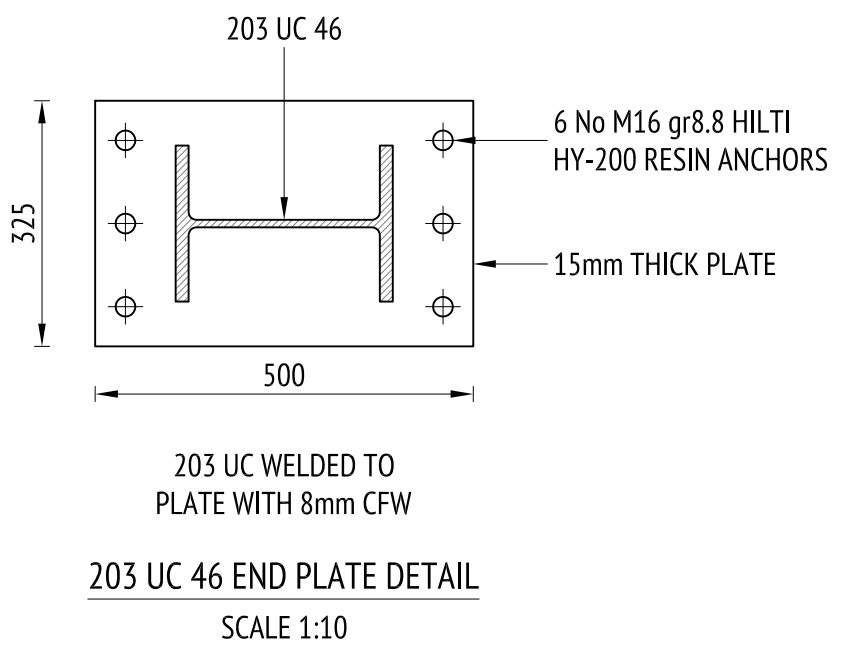
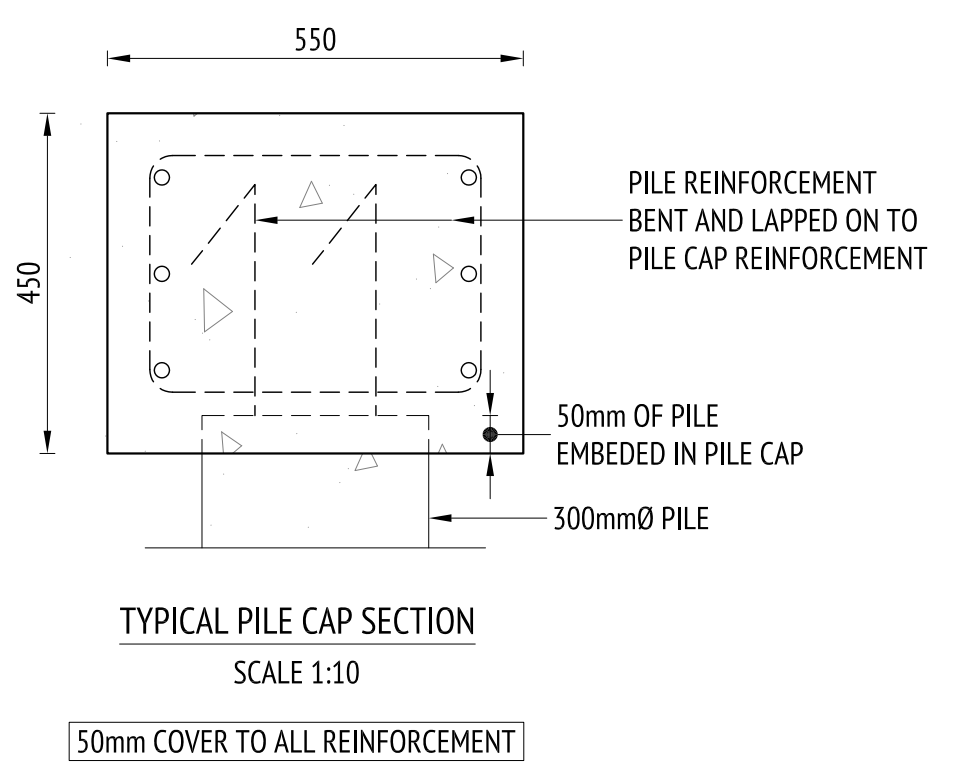
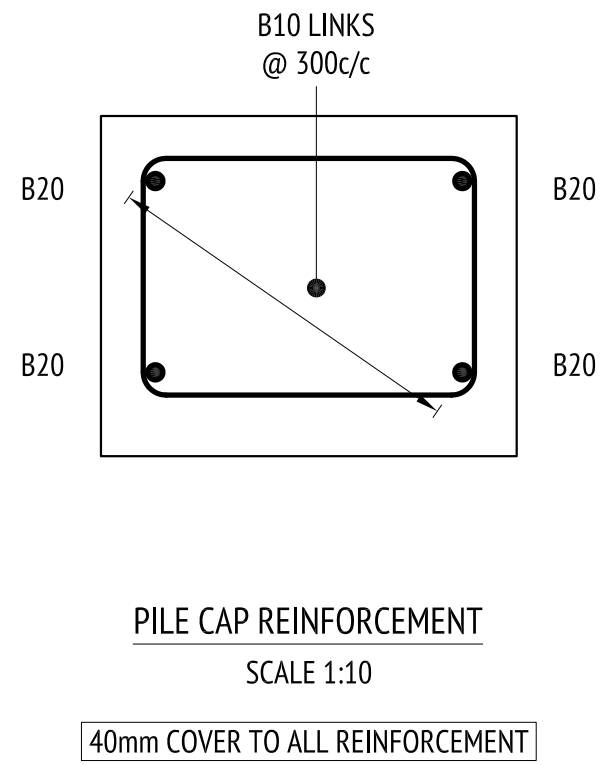

JAMES FRITH LTD
CONSULTING CIVIL AND STRUCTURAL ENGINEERS
+44 (0) 7876762553 | www.jamesfrithtd.com | office@jamesfrithtd.com

PROJECT: 15a PARLIAMENT HILL
TITLE: TEMPORARY WORKS PILING GA
STATUS: FOR INFORMATION
CLIENT: MH COSTA