

GWO Glazed Walk on Pavements

PaveVent Overview

Surespan PaveVents are designed with a pan type lid supporting the glass in a structural bond system which has a slim sight line.

PaveVent walk-on panels are designed in accordance with FACTA requirements.

Walk-on panels incorporate a specially formed anti-slip ceramic, permanently tempered onto the glass surface which can be printed in custom patterns or the standard 'Carborundum' finish. (3mm dot on a 12mm staggered pitch ref: GGSRT9)

STANDARD FEATURES

- Custom made to any size
- Rated up to FACTA Class C as required
- Anti-slip ceramic tempered onto the glass
- Maximum opening 85°
- Gas spring assisted operation
- Standard Tee Key Lock
- Hold open stay - against accidental closure

Material:	Grade 304 or 316 Stainless Steel with glass infill	
Cover:	Single or double leaf, hinged or lift out. Rated FACTA Class A - C loading.	
Frame:	Stainless steel frame. The access cover is not watertight but is self-draining. Any water passing the seals will be dispersed via an integral drainage channel, which is fitted with an optional internal or external ¾ inch flexible hose adaptor (for connection to drain by others) please state if required.	
Glass:	Walk-on panels incorporate a specially formed anti-slip ceramic, permanently tempered onto the glass surface which can be printed in custom patterns or in standard line and dot patterns.	
Finish:	The exposed edges of the covers can be vented or finished in a stainless steel trim (Optional)	
Options:	Stainless Steel grade 304 or 316 FACTA Class A to C Electric Operation	Concealed Gas Spring Pressure Sensitive Edge Powder Coated

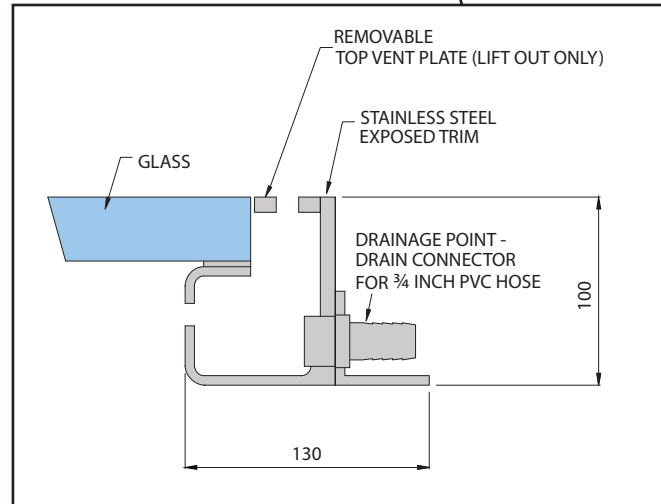
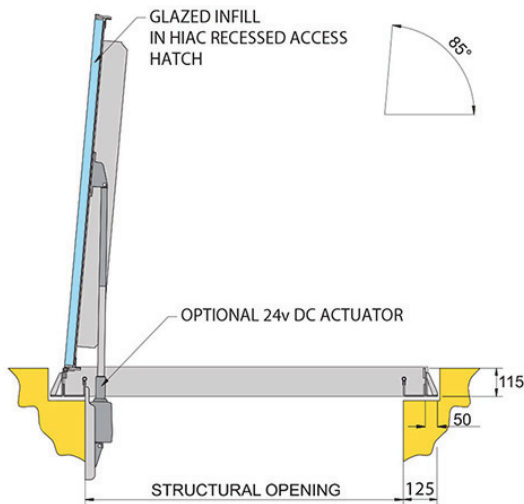
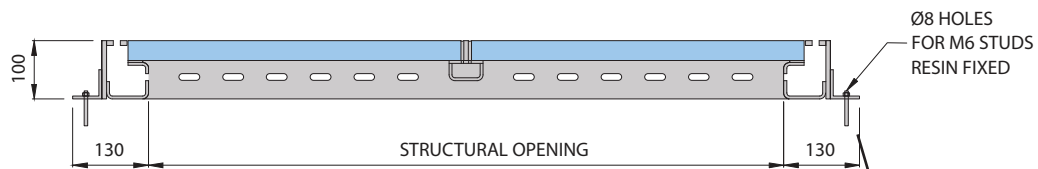

GWO Glazed Walk on PaveVents**Applications**