

THIRD FLOOR
1:200@A3

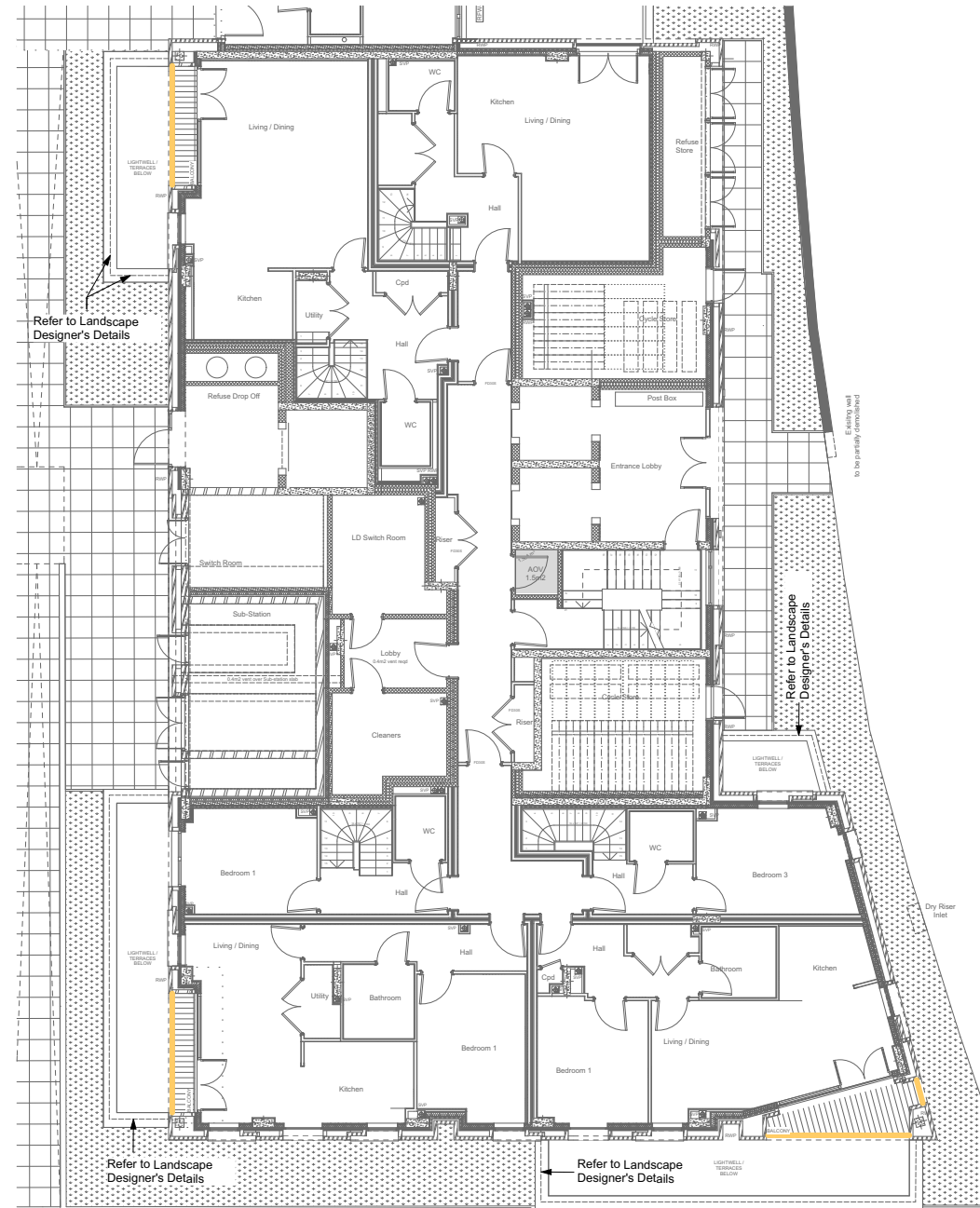

GROUND FLOOR
1:200@A3

- Balustrading Types
- BT1 | Glazed balustrade
 - BT2 | MS Metal railing PPC painted black to New Build
 - BT3 | MS metal railings hand painted black generally to Heritage Buildings. *
 - BT4 | Side-fixed MS Metal railing PPC painted black to New Build
 - BT5 | MS Metal handrails PPC painted black generally to New Build
 - BT6 | Translucent glazed privacy screens - etched glass to both sides
 - BT7 | Existing Railing to be Refurbished
- * Refer to BT3 Variation on Drawing 9000-DRG-00GN-DE004

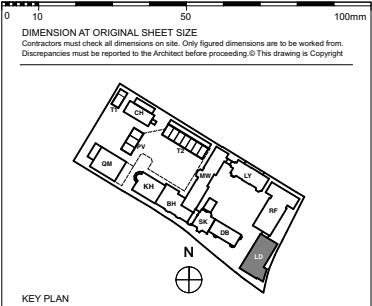

FOR TENDER

REVISION	DRN	CHKD	DATE
T1	First Issue	FC TW	07/09/16



CLIENT
MOUNT ANVIL LTD



PROJECT
KIDDERPORE AVENUE

DRAWING
Lord Cameron
Metalwork Diagram

SCALE As shown DATE May 2016

DRAWING No. 15 230 DRAWN BY EC
9000-DRG-16LD-VL001 REV T1

A & Q PARTNERSHIP (LONDON) LTD
THE LUX BUILDING, 2-4 HOXTON SQUARE, LONDON N1 6 NU
Tel: 020 7613 2244 Fax: 020 7613 2642 Email: london@aqp.co.uk
ARCHITECTURE DESIGN MASTERPLANNING INTERIORS

Metal U-shape capping piece
 PPC to RAL 7008

Proprietary structural glass
 balustrade secured with bottom
 clamp

Track assembly details & fixings to
 specialist details

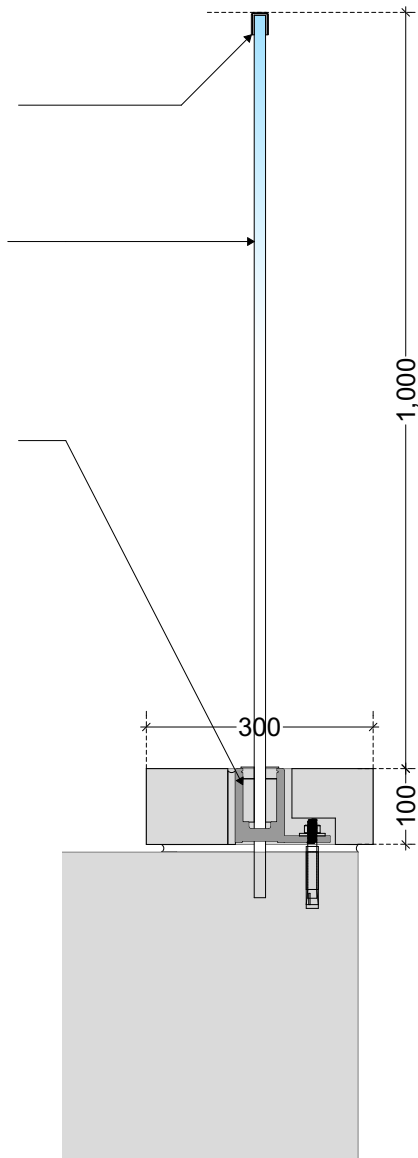

SECTION 1 - GLAZED BALUSTRADE
 GENERALLY TO LIGHTWELLS - TYPE BT1
 1:10@A3

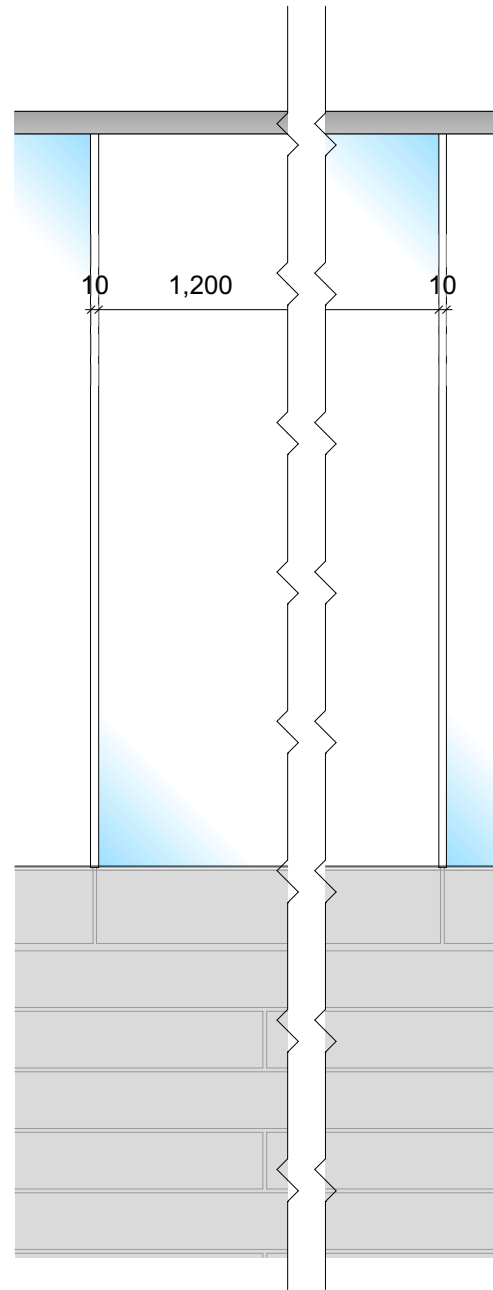

ELEVATION 1 - GLAZED BALUSTRADE
 GENERALLY TO LIGHTWELLS
 1:10@A3

Metal circular top rail
 PPC to RAL 7008

Proprietary structural glass
 balustrade secured with bottom
 clamp

Stainless steel track fixed to
 concrete slab with a base channel.
 All to manufacturers details and
 specification.

Metal stub to specialist details

BUILD-UP
 VARIES

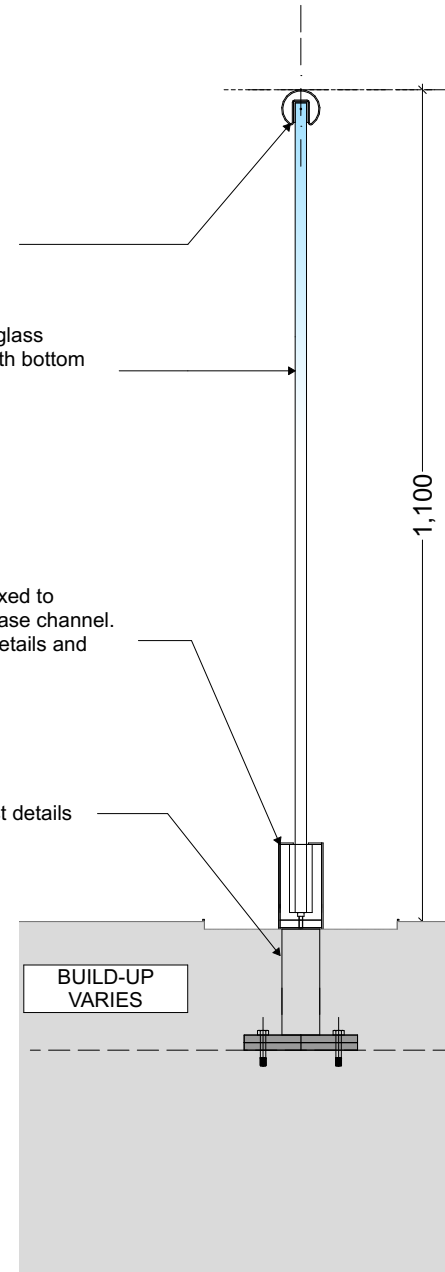

SECTION 2 - GLAZED BALUSTRADE
 GENERALLY TO ROOF/ TERRACES / BALCONIES - TYPE BT1A
 1:10@A3

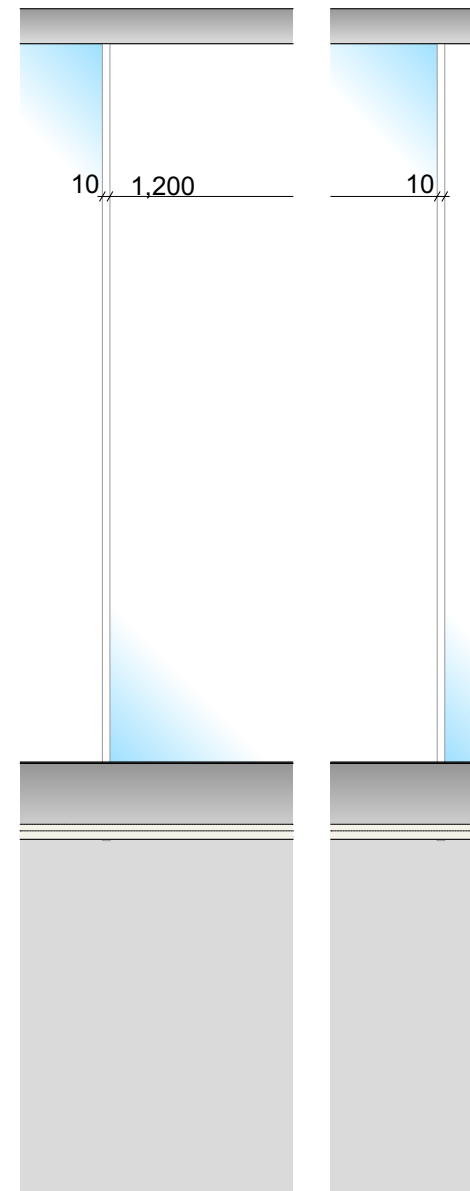

ELEVATION 2 - GLAZED BALUSTRADE
 GENERALLY TO ROOF/ TERRACES /
 BALCONIES
 1:10@A3

FOR TENDER

REVISION	DRN	CHKD	DATE	
T1	First Issue	EC	TW	08/08/2016

A&Q
 PARTNERSHIP

CLIENT
 MOUNT ANVIL LTD



PROJECT
 KIDDERPORE AVENUE

DRAWING
 Generally Applicable
 Balustrading Types - BT1 And BT1A

SCALE As shown DATE
 May 2016

DRAWING No. DRAWN BY
 15 230 EC
 9000-DRG-16GN-DE001 REV
 T1

A & Q PARTNERSHIP (LONDON) LTD
 THE LUX BUILDING, 2-4 HOXTON SQUARE, LONDON N1 6 NU
 Tel: 020 7613 2244 Fax: 020 7613 2642 Email: london@aqp.co.uk
 ARCHITECTURE DESIGN MASTERPLANNING INTERIORS

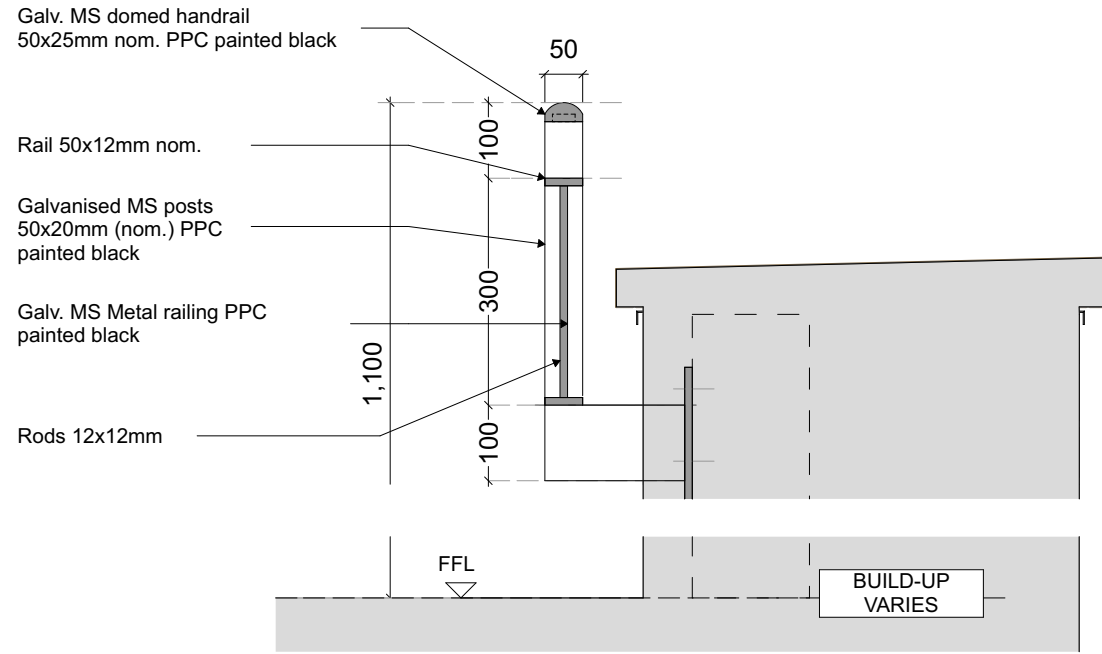

SECTION 1 - TYPICAL SIDE-FIXED MS METAL RAILING (MODERN)
TYPE - BT4
 1:10@A3

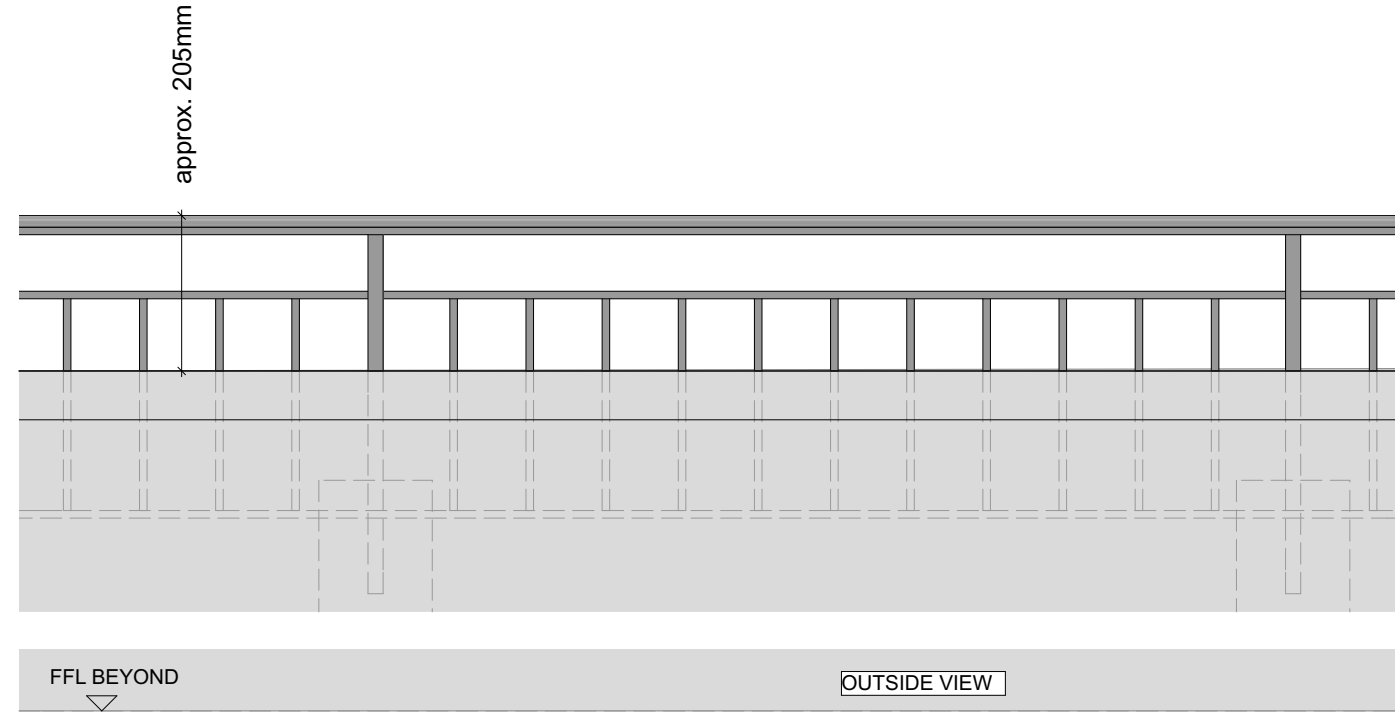

ELEVATION 1 - TYPICAL SIDE-FIXED MS METAL RAILING (MODERN)
 1:10@A3

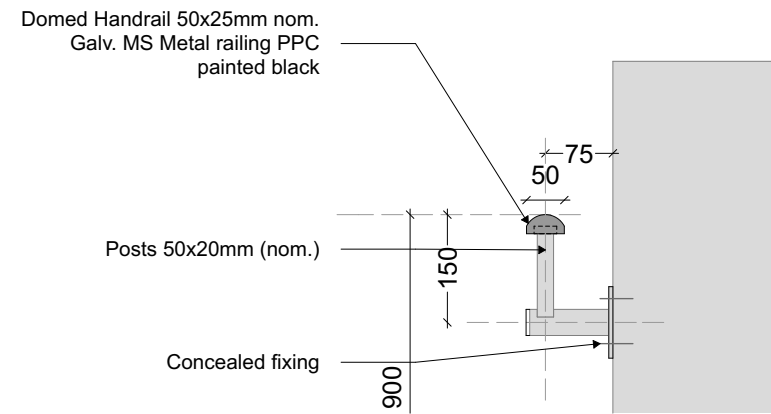

SECTION 2 - TYPICAL SIDE-FIXED MS METAL HANDRAIL (MODERN)
TYPE - BT5
 1:10@A3

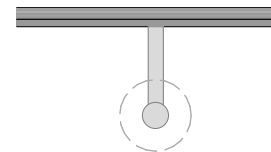

ELEVATION 2 - TYPICAL SIDE-FIXED MS METAL RAILING (MODERN)
 1:10@A3

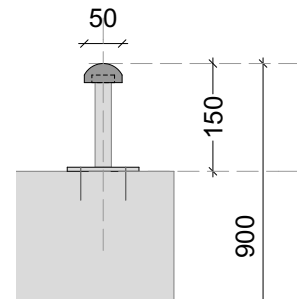

SECTION 3 - TYPICAL TOP-FIXED MS METAL HANDRAIL (MODERN)
TYPE - BT5
 1:10@A3

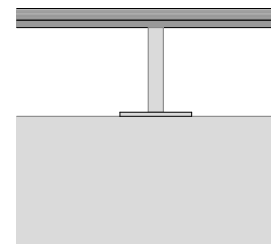

ELEVATION 3 - TYPICAL TOP-FIXED MS METAL RAILING (MODERN)
 1:10@A3

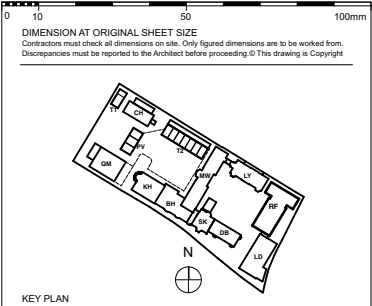

KEY PLAN

FOR TENDER

REVISION	DRN	CHKD	DATE	
T1	First Issue	EC	TW	08/08/2016



PROJECT
 KIDDERPORE AVENUE

DRAWING
 Generally Applicable
 Balustrading Types - BT4 And BT5

SCALE As shown DATE May 2016

DRAWING No. 15 230 DRAWN BY EC
 9000-DRG-16GN-DE005 REV T1

A & Q PARTNERSHIP (LONDON) LTD
 THE LUX BUILDING, 2-4 HOXTON SQUARE, LONDON N1 6 NU
 Tel: 020 7613 2244 Fax: 020 7613 2642 Email: london@aqp.co.uk
 ARCHITECTURE DESIGN MASTERPLANNING INTERIORS