

AN INTRODUCTION TO SKYLINE

Skyline elevators is a professional technical lift service with 15 years of experience.

We provide a complete service that covers repair, modernisation, installation and an array of service contracts. All our test engineers are trained to the highest standards and are practiced in health and safety accreditations. Staff training is constantly re-evaluated so keeping a breadth with new technology on lift systems traction or hydraulic. Skyline are accredited with ISO 2000 which ensures our customer of an outstanding performance record with the emphasis being on a 24 hour a day service for 365 days per year.

- **Lift service and planned maintenance**
- **24hr Breakdown and Repairs**
- **Modernisations**
- **New Installations**
- **Upgrades, LG Inspections and DDA works**



SAFETY & SECURITY

When you sign a contract with Skyline Elevators you can be sure that all your lift requirements meet the necessary government health and safety policies. With increasing European legislation prevailing with the UK covering all aspects of health and safety within the public sector is paramount. Skyline will ensure that all its clients are kept fully informed about current regulations.



Health and safety issues are paramount to Skyline. We are therefore fully conversant with:

- The Management of Health and Safety at Work Regulations 1999.
- The Health and Safety at Work etc Act 1974
- Lifting Operations and Lifting Equipment Regulations 1998 (LOLER)
- The Provision and Use of Work Equipment Regulations (PUWER)
- Safety Assessment Federation (SAFed)
- BS 7255 Safe Working on Lifts

SERVICES

All lift systems require regular and expert maintenance to ensure passenger safety, reliability and performance. We maintain all type and makes of lifts with our dedicated staff to a very high standard, offering customers the piece of mind you expect. Our service and technical staff provide 24hr 365 days a year assistance ready to take on any problem with the minimum of delay. Qualified engineers are available should you require permanent resident staff to ensure continuous presence on site.

We provide regular service and Risk Assessment reports to keep you informed of any statutory requirements together with reliability and safety issues giving you accurate data to help budget for any future expenditure.

With our integrated computer system we ensure engineer response times are kept to a minimum for any repair or breakdown. Contact us to arrange a detailed inspection of your lift system without obligation to provide you with a competitive quotation for repair or maintenance.



MODERNISATION

Our integrated team of professionals will give your lift system a new lease of life, expertly installing new equipment for old, to meet your budgetary requirements.

Whenever your lift system was originally installed we will work to develop a package to meet your needs. We will improve performance, reliability and safety as well as bringing your equipment up to date. Tailoring the modernisation to meet your own personal needs.

INSTALLATION

Skyline Elevators are highly skilled and able to install any type of lift installation, whether traction or hydraulic, and single to group lift systems. Our expertise and experience enables us to deliver the right product on time and on budget, maintaining close liaison with site personnel and allied trades to ensure a smooth and safe installation.



We supply and install the following:

- Passenger lifts
- Goods and Service lifts
- Group lift systems
- Machine Roomless lifts
- Scenic lifts
- Scissors platform lifts
- Disabled access lifts and stair lifts

REPAIRS

Skyline Elevators are skilled at carrying out Lift Guidance (LG) 'examinations and test' inspections, producing reports on reliability and safety. We also carry out free Disability Discrimination Act (DDA) and insurance inspection surveys, producing reports on compliance, followed up with a competitive quotation.



Certificate of Registration

This is to certify that:

Skyline Elevators Limited
Unit J, Wrexham Road
Laindon
ESSEX
SS15 6PX

Has been assessed by Lift Cert Limited in respect of their Documented Management Systems and found to comply with:

BS EN ISO 9001:2008
Quality Management Systems

This registration is subject to the company maintaining a documented management system to the above standard which will be monitored by Lift Cert Ltd in accordance with the Scheme Rules.

Certification Scope:

**THE DESIGN, SUPPLY, INSTALLATION, MODERNIZATION, TEST
AND SERVICING OF LIFTS.**

Date First Issued: 23rd February 2009
Date Re-Issued: 29th April 2014

Valid Until: 28th April 2017
EAC Code: 18/28
Cert No. 42080255/Q70

LIFT CERT Authorised Signatory



M. Miles – Managing Director

Registered in England & Wales
No: 4566351

Registered Office:
LIFT CERT LIMITED
40 Tiddington Road
Stratford on Avon
Warwickshire
CV37 7BA

Tel: 01789 295300
Fax: 01789 415749
E-mail: headoffice@liftcert.co.uk





Lift & Escalator Industry Association

This is to certify

Skyline Elevators Ltd

*is a Member of the Association and
has undertaken to support its aims
and objectives and abide by the
Terms of Membership*

Membership Number:

265

LEIA

33/34 Devonshire Street, London W1G 6PY

Tel: 020 7935 3013 Fax: 020 7935 3321

Email: enquiries@leia.co.uk

www.leia.co.uk

2016MEMBER



Certificate of Registration

This is to certify that:

Skyline Elevators Limited
Unit J, Wrexham Road
Laindon
ESSEX
SS15 6PX

Has been assessed by Lift Cert Limited in respect of their Quality Management Systems and found to comply with:

THE LIFTS REGULATIONS 1997: SCHEDULE 12
(95/16/EC ANNEX XIII) NOTIFIED BODY NUMBER: 1291

Approval is hereby granted for registration providing the rules and conditions relating to certification are observed at all times.

Certification Scope:

**DESIGN, SUPPLY, INSTALLATION AND FINAL TEST OF NEW PASSENGER
LIFTS WITHIN THE SCOPE OF EN81:1998 Parts 1 & 2 and EN81 Part 21.**

Date First Issued: 12th November 2008
Date Re-Issued: 14th February 2015

Valid Until 14th February 2018

Cert No. 42080255/1291

LIFT CERT Authorised Signatory



M. Miles – Managing Director

Registered in England & Wales
No: 4566351

Registered Office:
LIFT CERT LIMITED
40 Tiddington Road
Stratford upon Avon
Warwickshire
CV37 7BA

Tel: 01789 295300
Fax: 011789 415749
E-mail: headoffice@liftcert.co.uk





CONTRACTORS HEALTH & SAFETY ASSESSMENT SCHEME

Certification Mark
www.chas.co.uk

Assessment Scheme

Certificate of Accreditation

This is to certify that

Skyline Elevators Ltd

is accredited within the Contractors Health and Safety Assessment Scheme (CHAS) having demonstrated compliance with and sound management of current basic health and safety legislation.

Valid until: 10 November 2016

Working in partnership with business



020 8545 3838 –  to verify
www.chas.co.uk

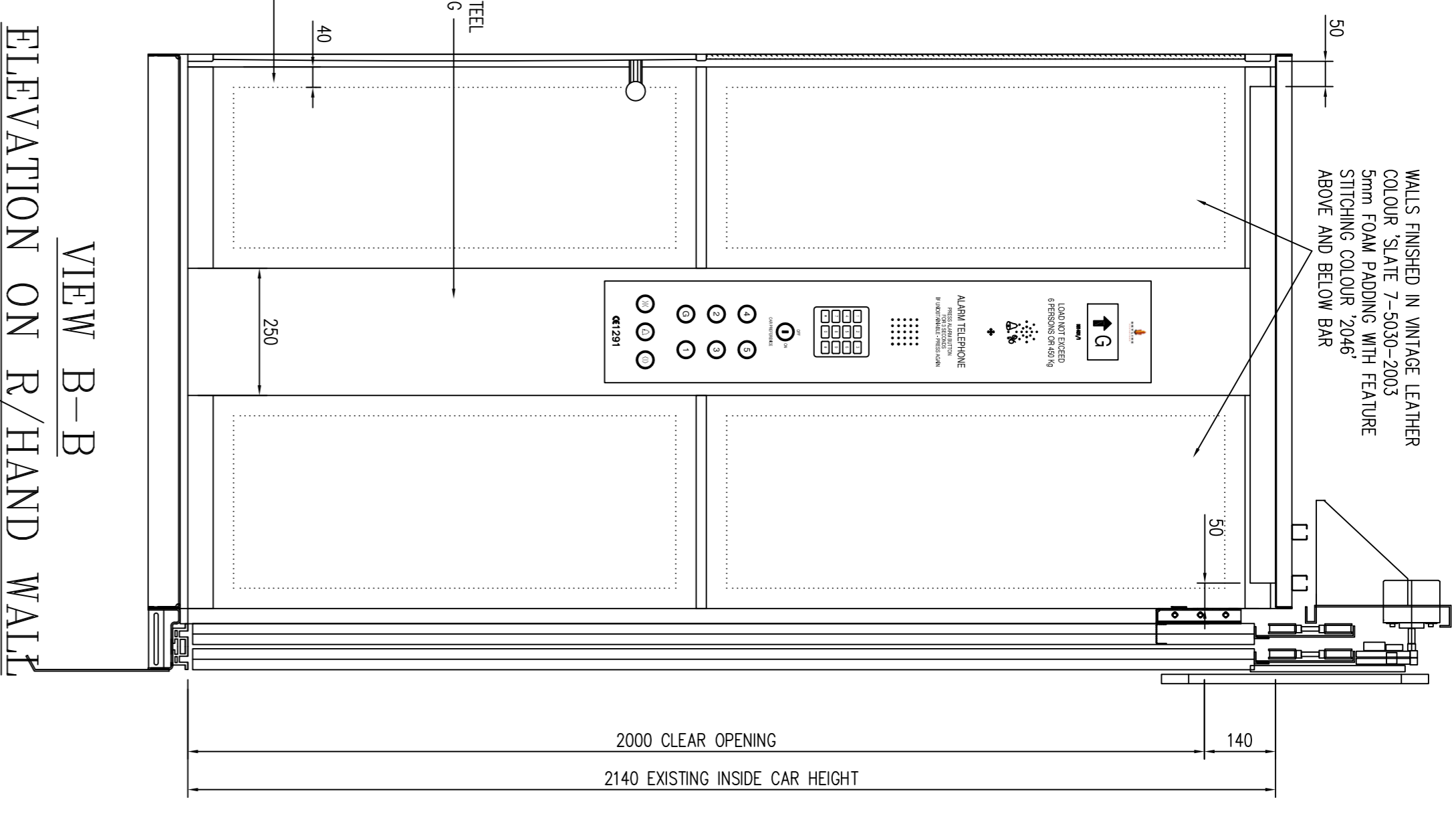
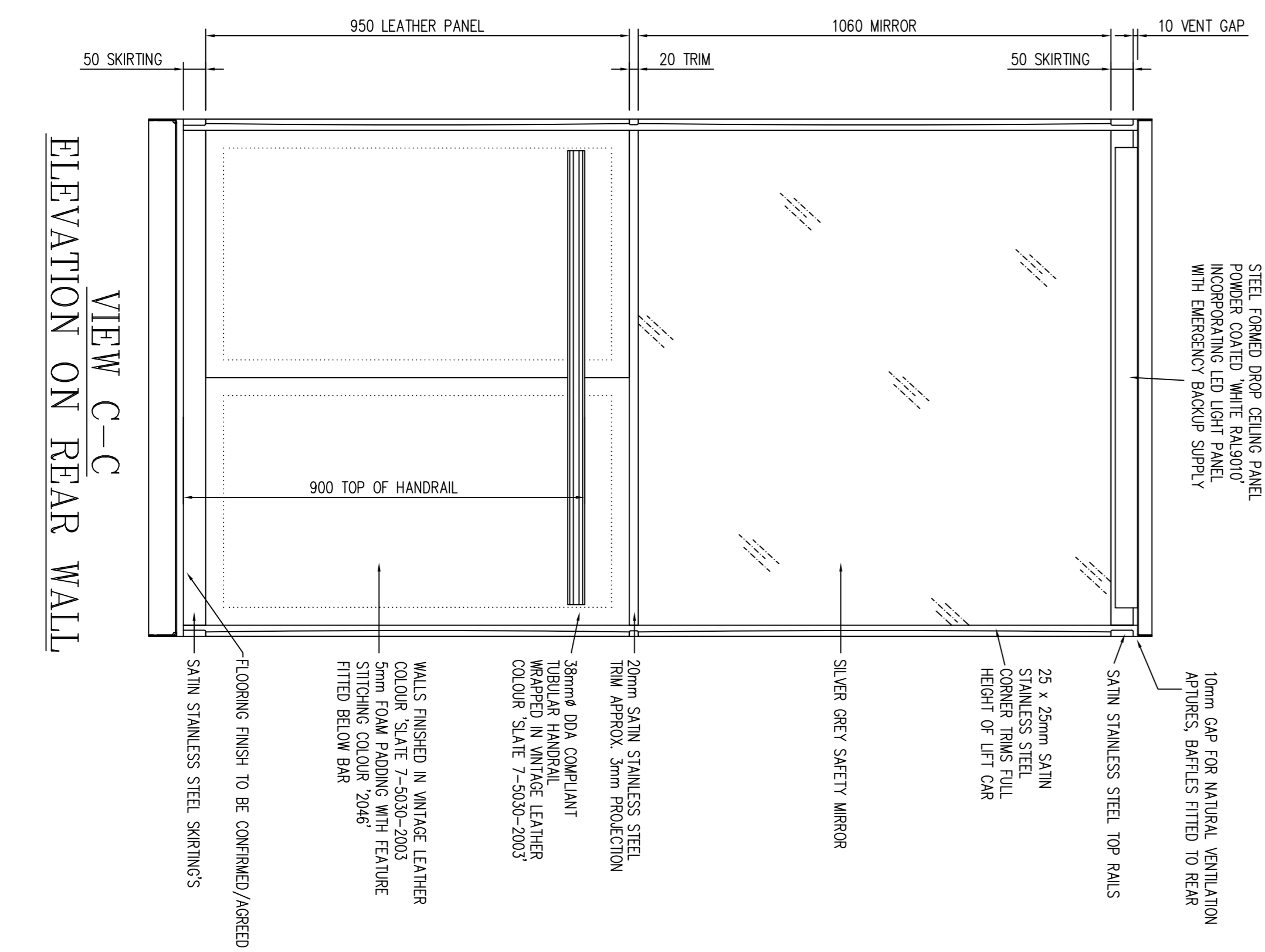
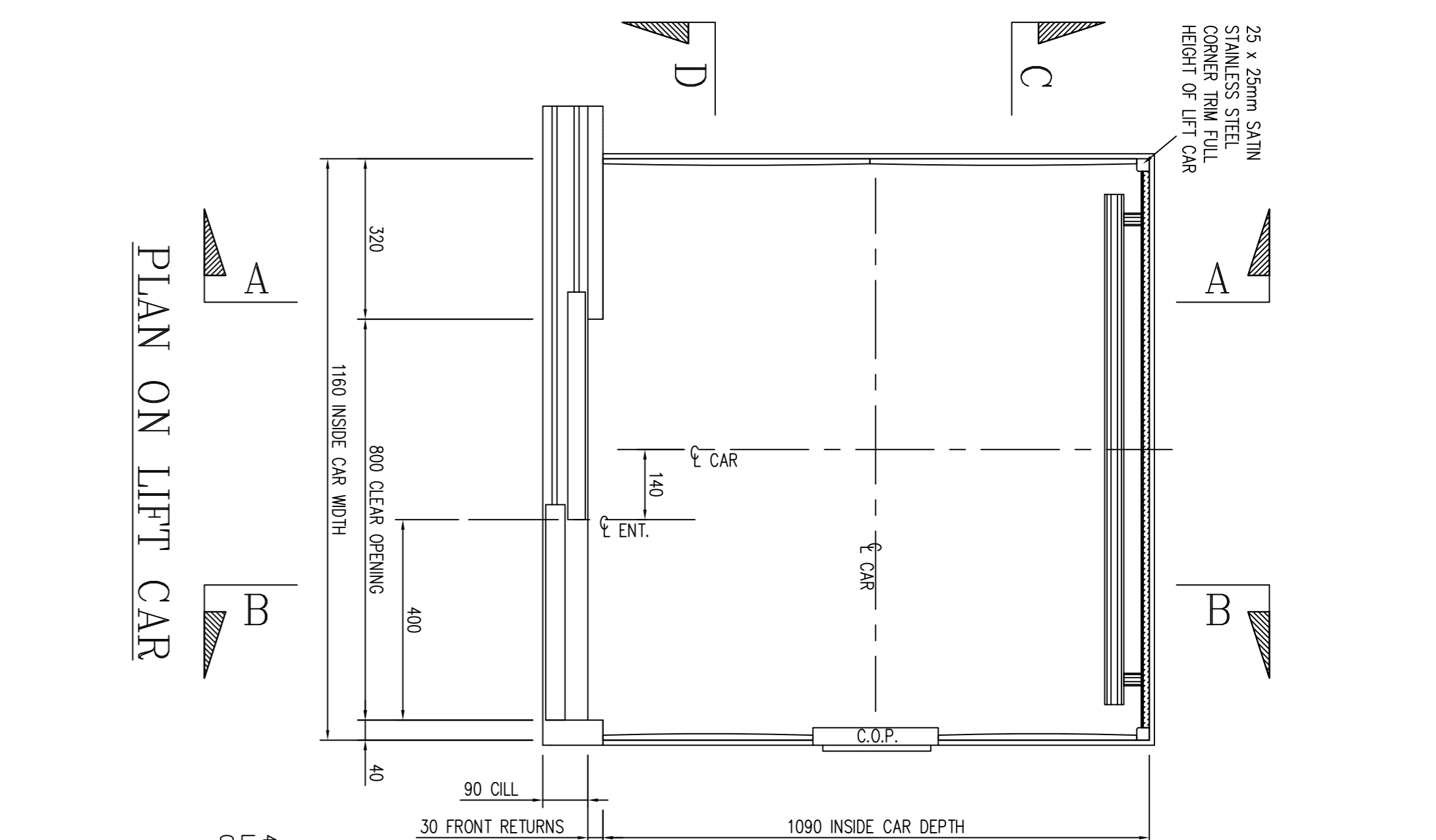
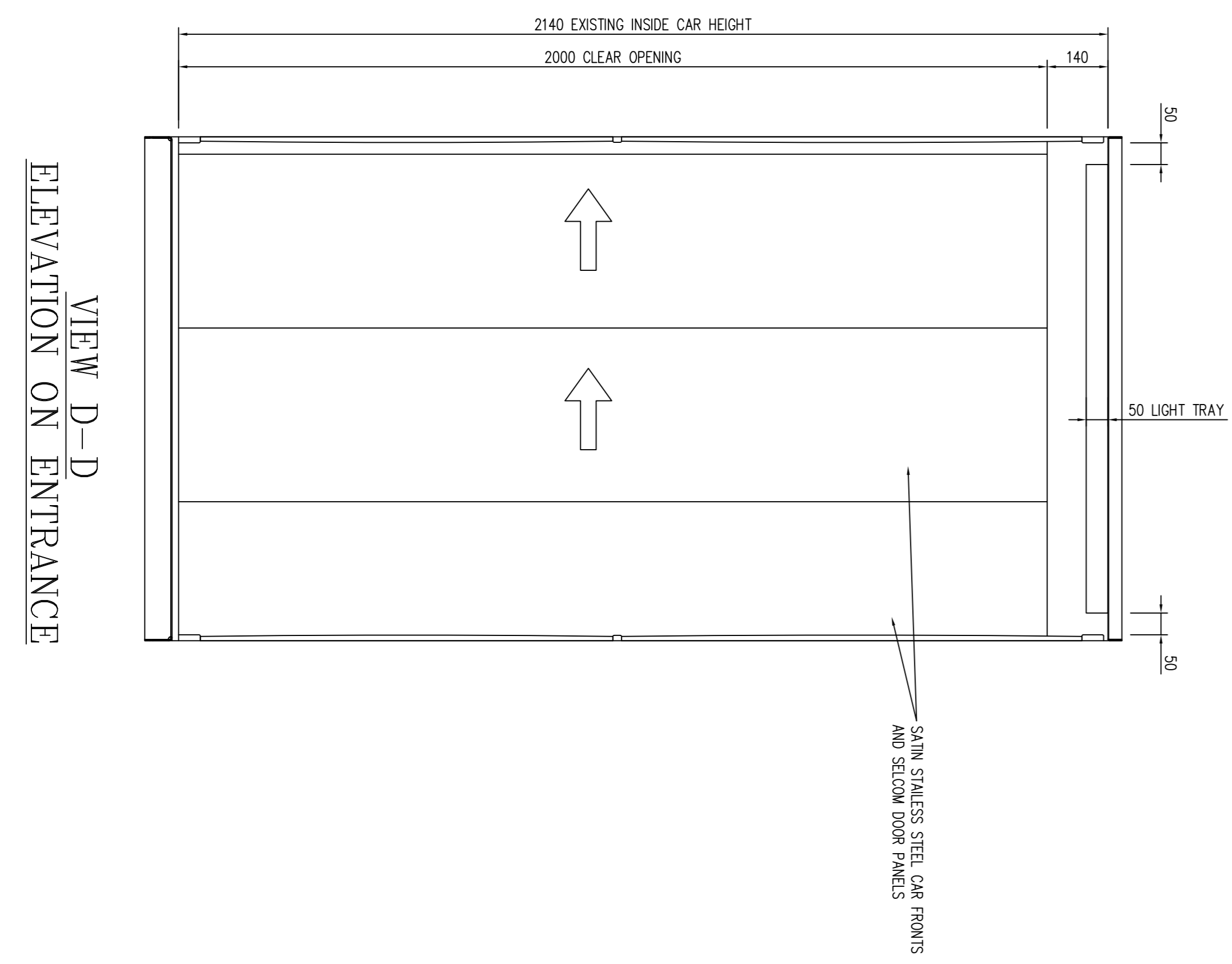
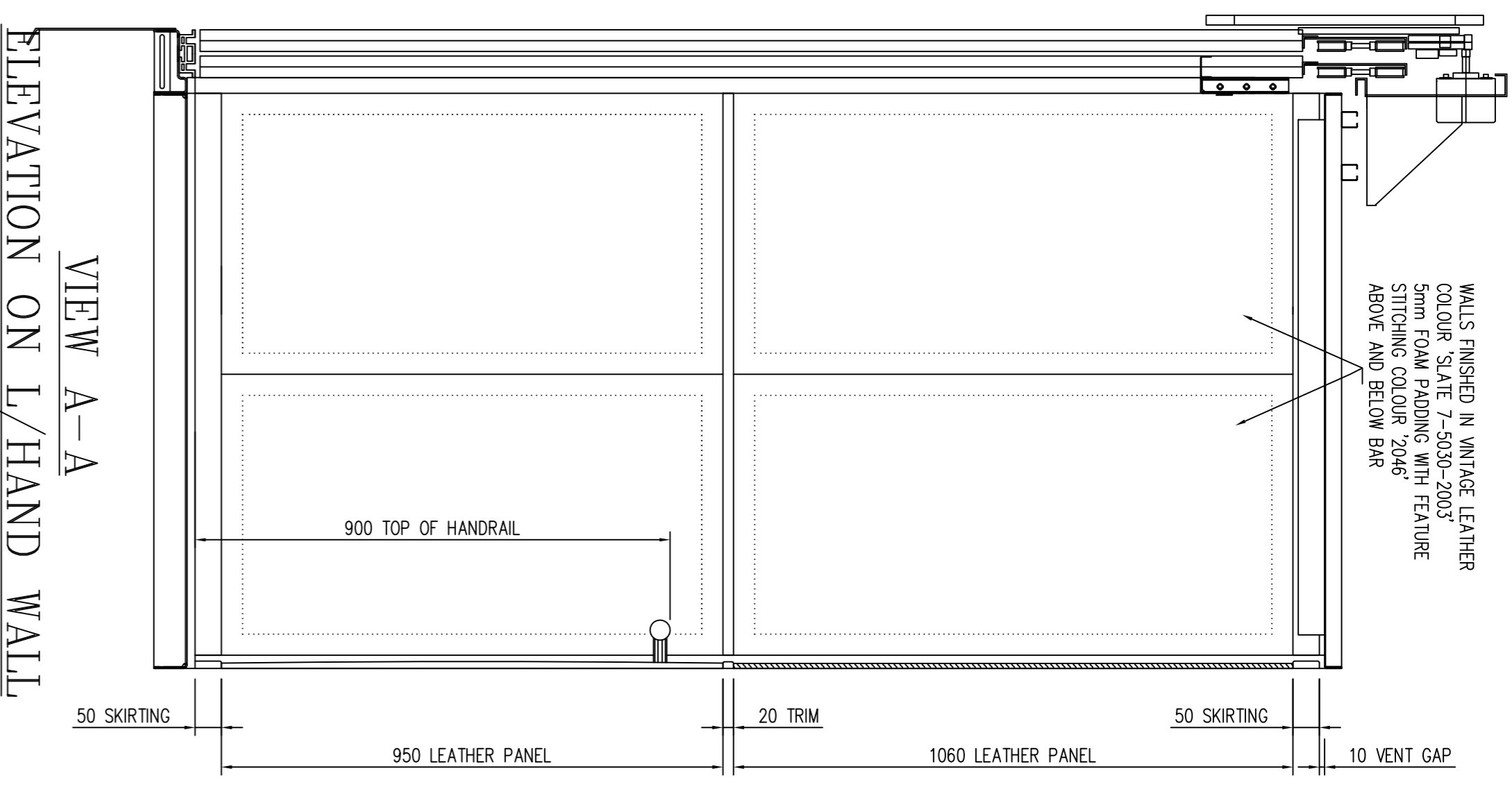
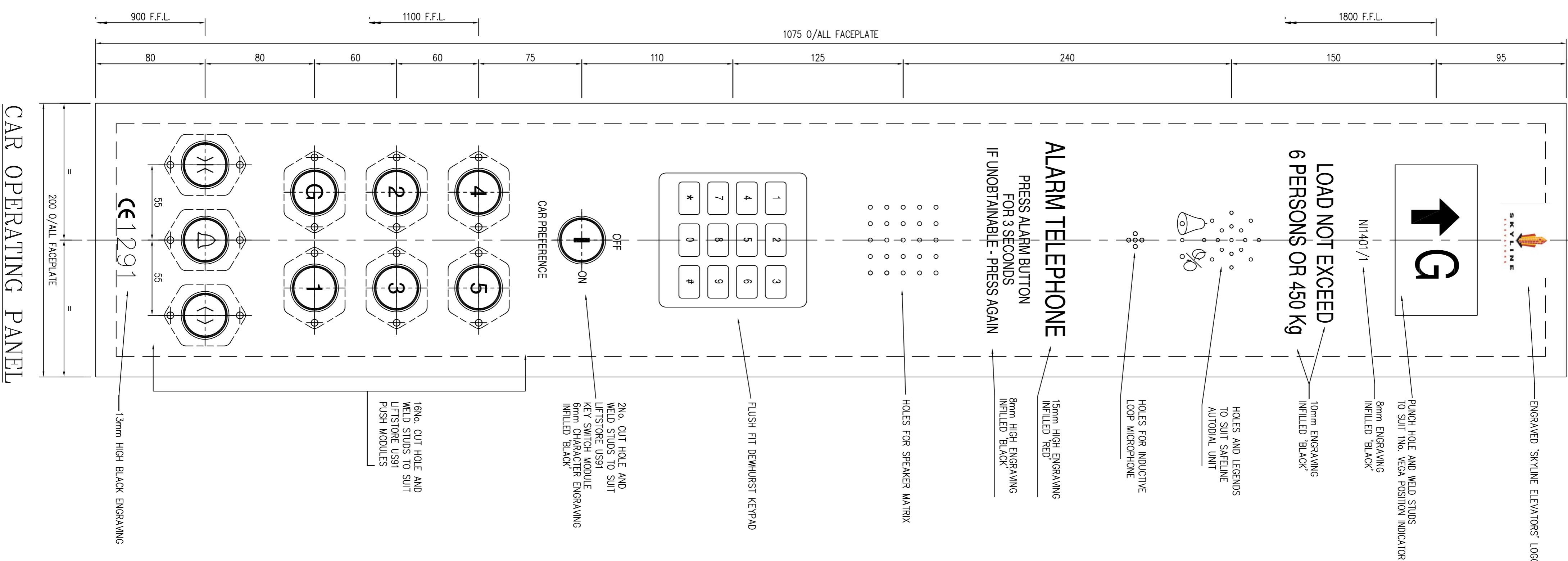

Drawn: RMT	Checked: WF	1401N/1
Scale: 1:2, 1:10 @M1	Date: 15/10/2016	Sht. No 1 of 2
DO NOT SCALE		Rev. 00
Drawing No 1401N/1/009/01		

Rev	Date	Revision
00	15/10/16	ISSUED FOR COMMENT

SKYLINE SKYLINE ELEVATORS LTD. 2 Merdoun Road Bessington Epsom Surrey SS15 6PX Tel: 07268 414295 Fax: 07268 545883 EMAIL: sales@skylineelevators.co.uk http://www.skylineelevators.co.uk/		TO BE APPROVED LIFT CAR FINISH DETAILS
Project: MUSEUM HOUSE 25 MUSEUM STREET LONDON		Title: LIFT CAR FINISH DETAILS

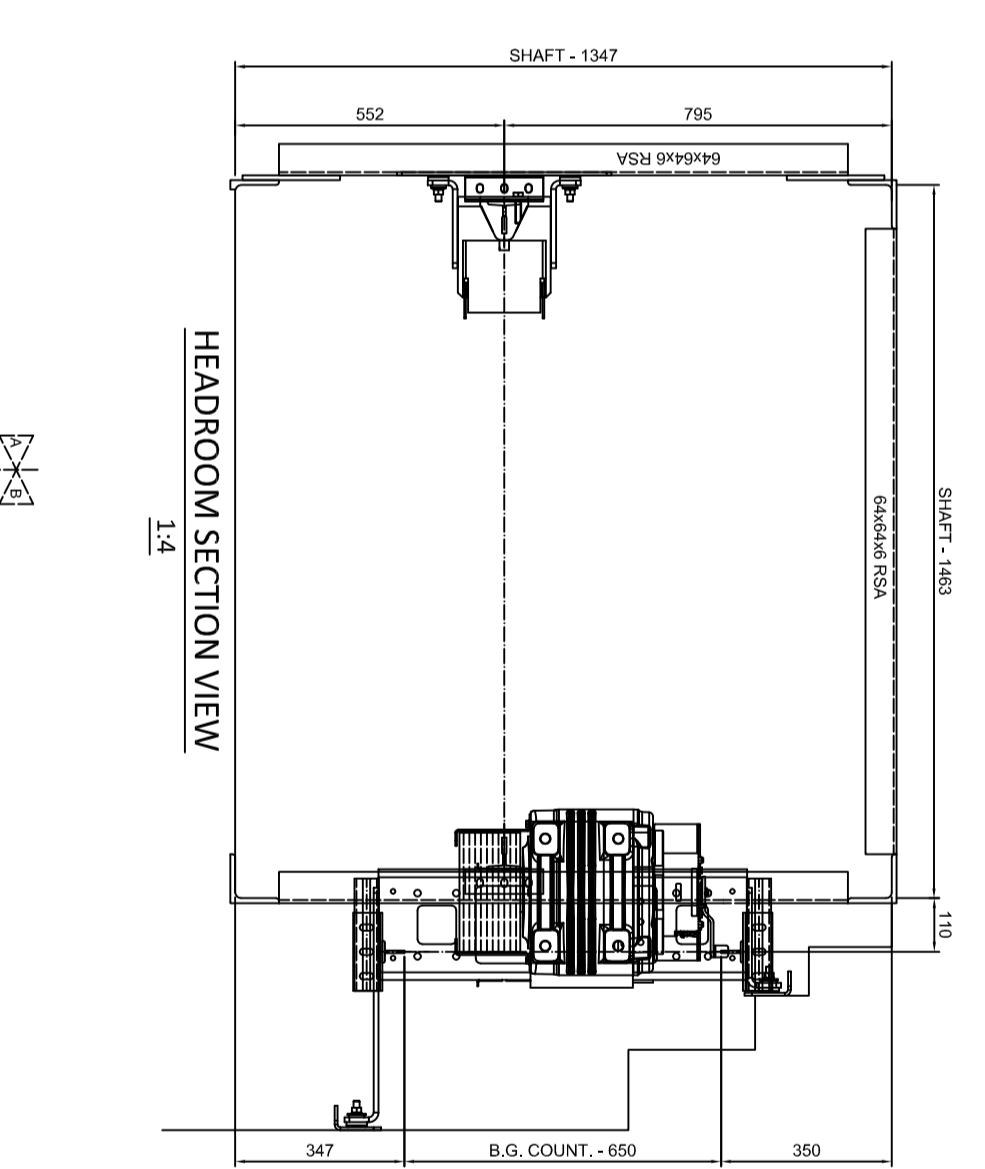
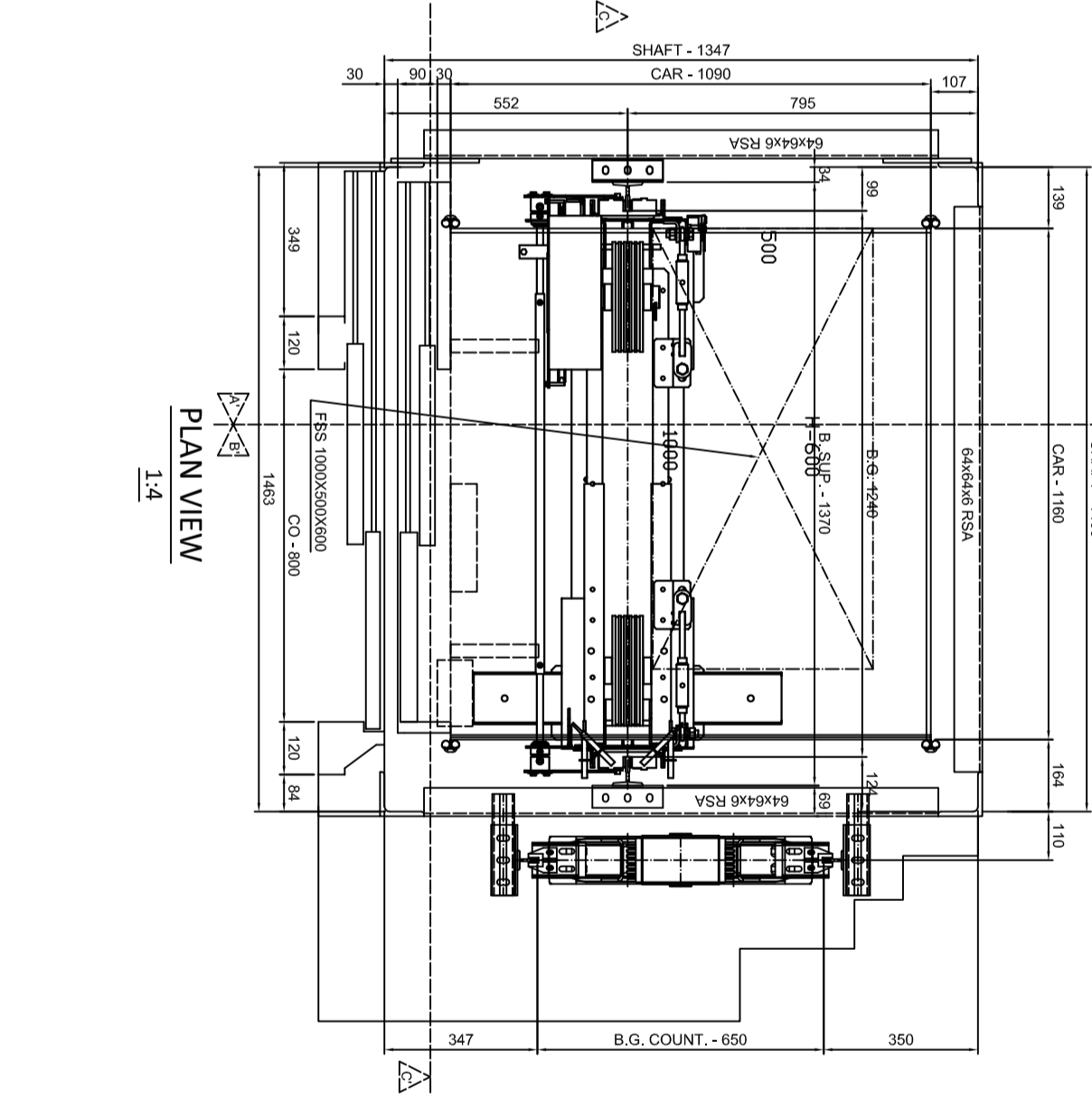
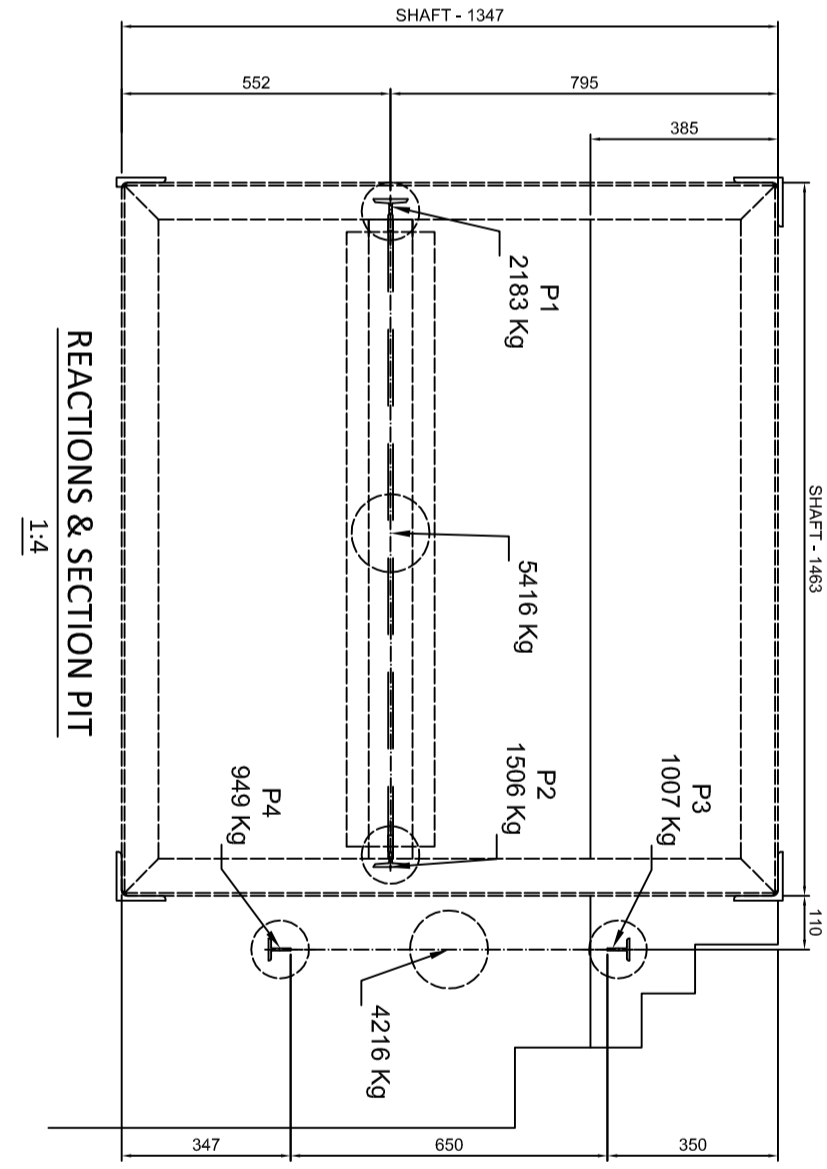
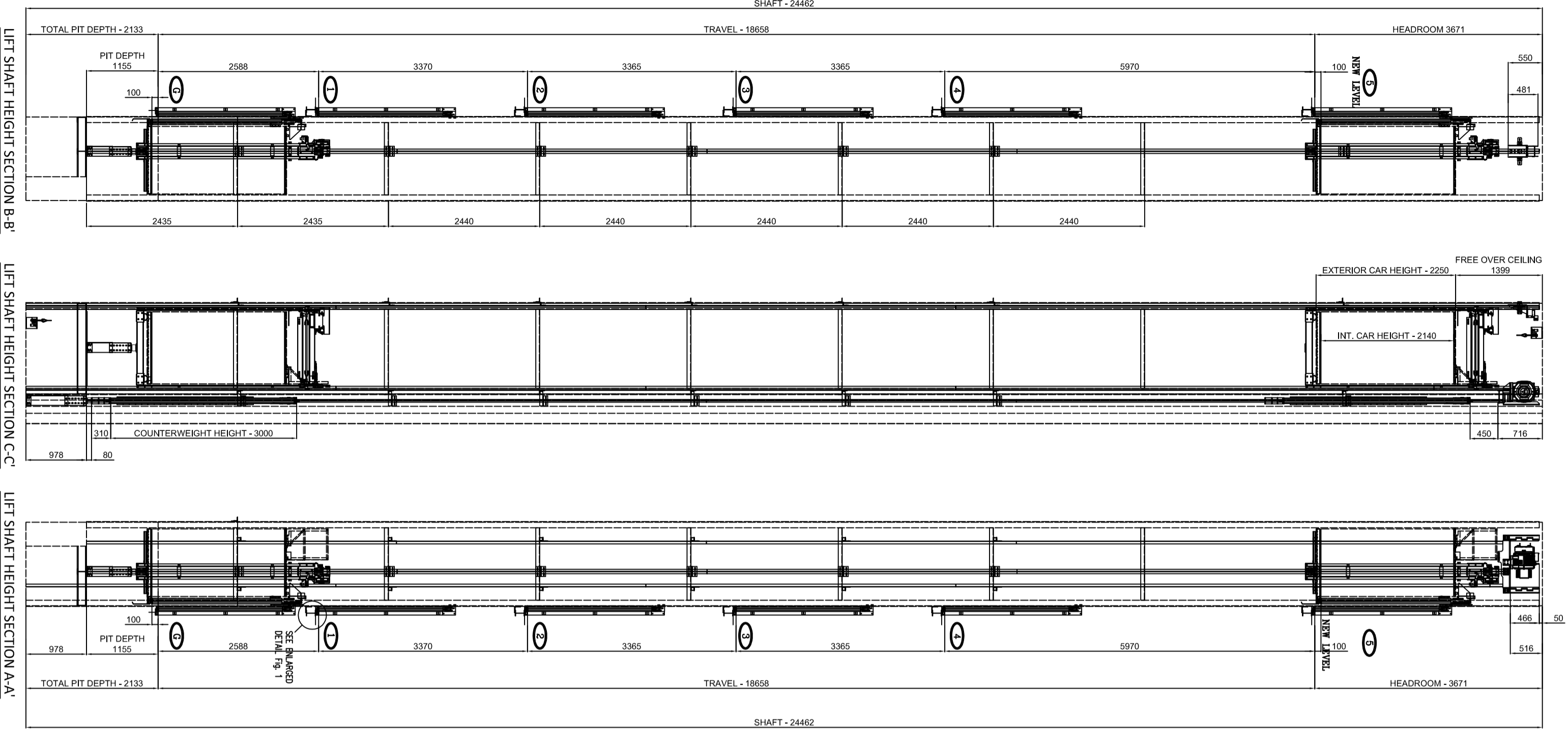

SPECIFICATIONS

TYPE	EXPLORER
USAGE	PASSENGER ELEVATOR
CAPACITY	430 KG., P6
SPEED m/s	1.0 m/s
POWER	380V
MACHINE	SICOR SG20180B, Gearless Traction
CONTROLLER	AC-VVVF SELECTIVE COLLECTIVE
LIFT CAR	WIDTH: 1160 DEPTH: 1090
ENTRANCE	WIDTH: 800 HEIGHT: 2000
TYPE OF DOORS	2-PANEL LEFT TEL. OPENING
RAIL	CAR T-70/9 CWT T-45/5
ROPE	RATIO=2:1 5 x Ø6.5
BUFFER	CAR SPRING BUFFER CWT SPRING BUFFER
SPEED GOVERNOR	CAR DYNA TECH STAR CWT -
SAFETY GEAR	CAR GERVALL M249/2000 CWT -

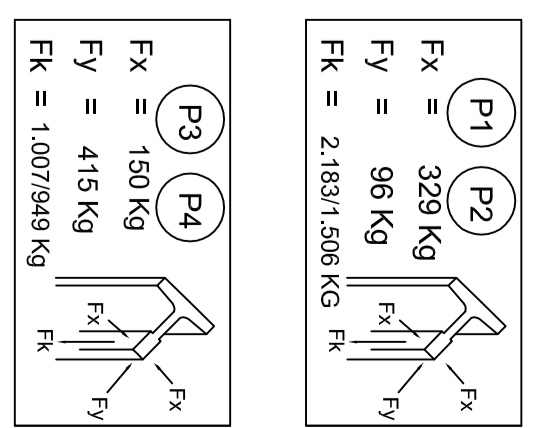
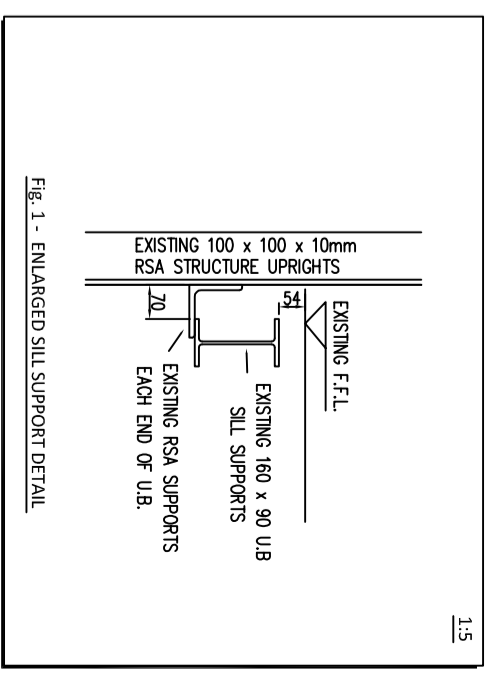

FOR INFORMATION

EXISTING STRUCTURE DETAILS

NO.	REVISION	ISSUED FOR COMMENT	DATE

PROJECT: MUSEUM HOUSE, 23 MERRIM STREET, CAMBRIDGE, MASSACHUSETTS

DATE: 08/20/2008

SCALE: 1/4

FIG. NO. 1 OF 1