

- General Notes**
1. Drawings shall be referred to for structural work only unless otherwise stated and read in conjunction with Architect's, Service Engineer's and Sub-Contractor's drawings.
 2. The Contractor shall check all levels and dimensions, any errors or omissions are to be reported at once to the Engineer.
 3. For General Notes refer to no. 9100-DRG-99YY-GN002.

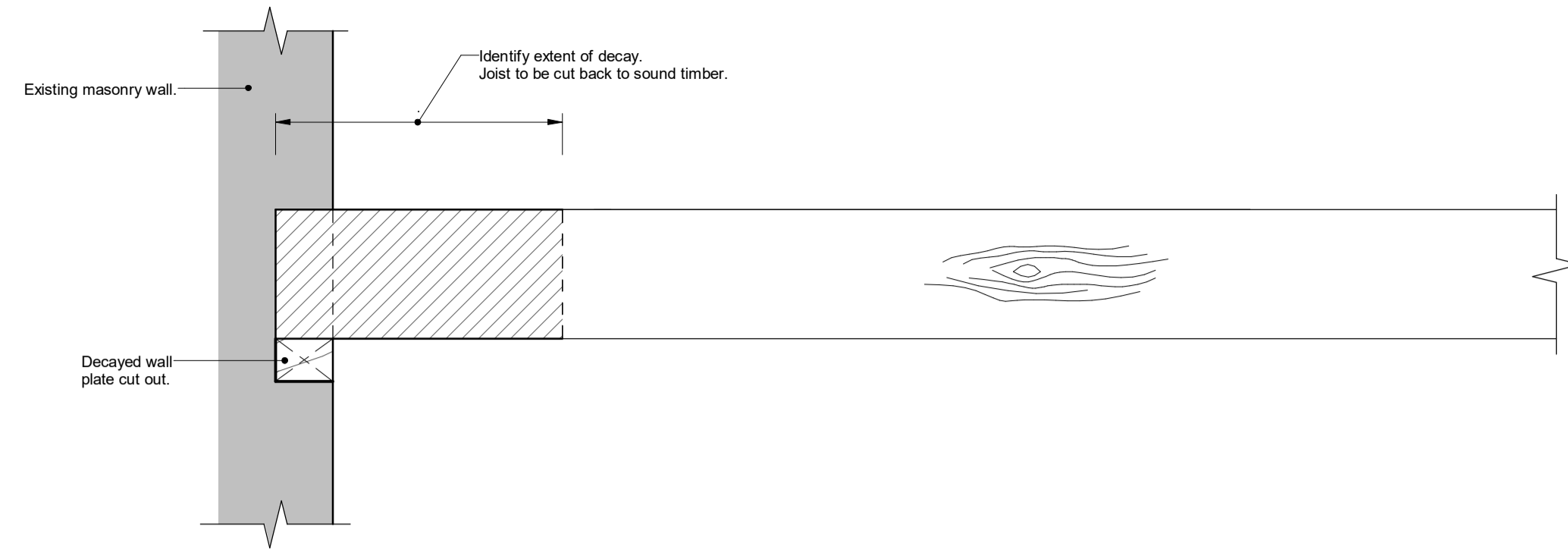

Detail 1: Decayed Joist End & Wall Plate:
Existing Detail
scale 1 : 10

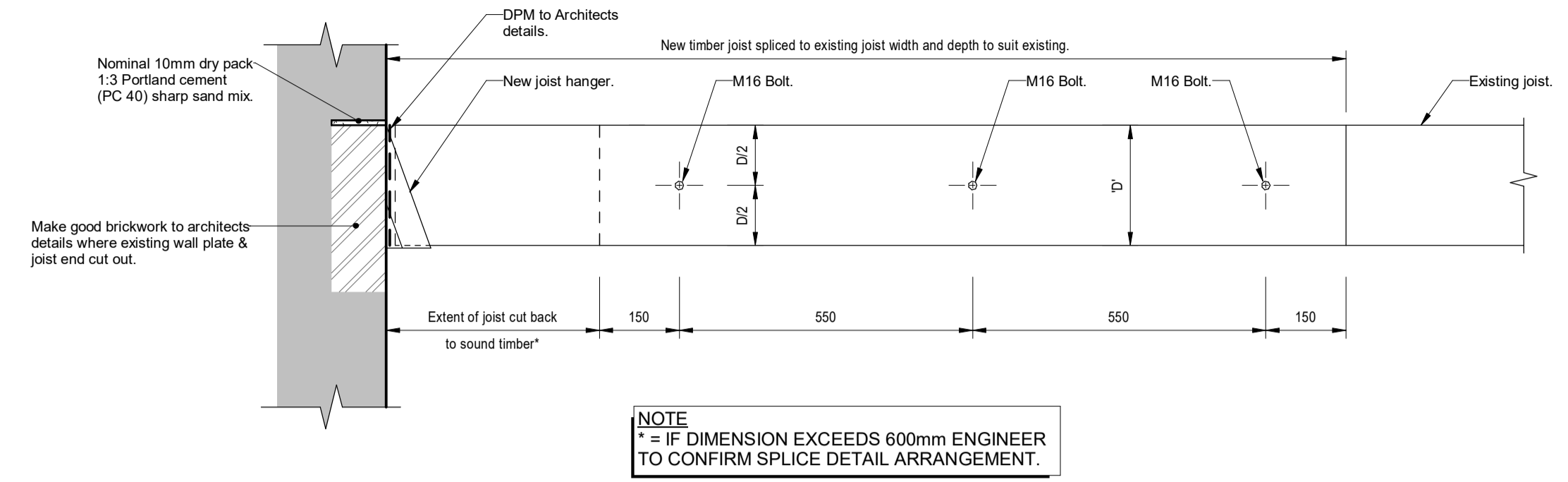

Detail 2: Decayed Joist End & Wall Plate:
Proposed Splice Detail
scale 1 : 10

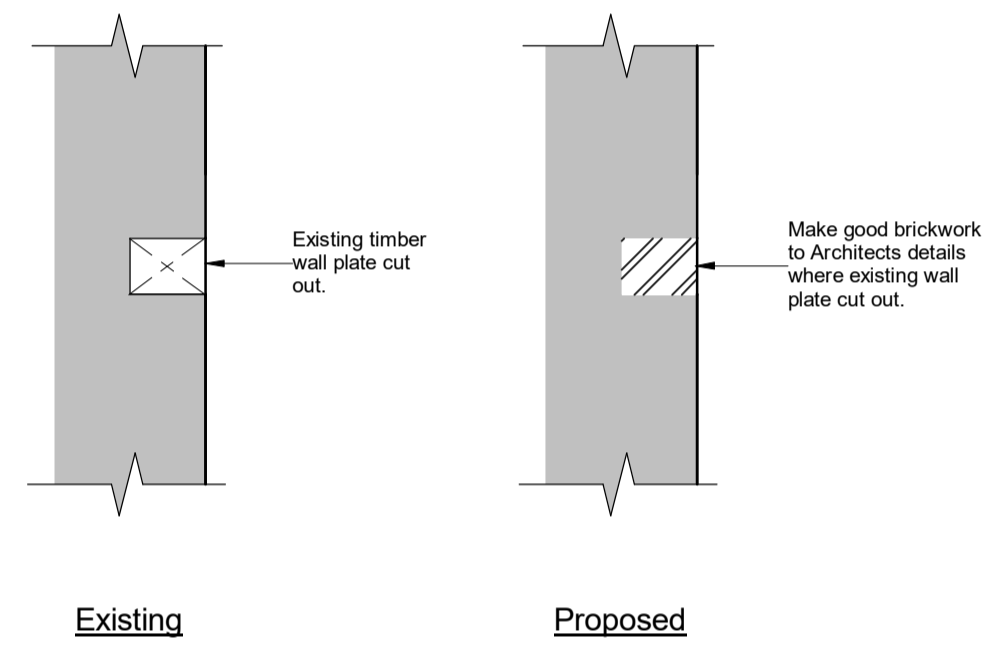

Detail 3: Decayed Wall Plate Where Joists Supported: Existing & Proposed Detail
scale 1 : 10

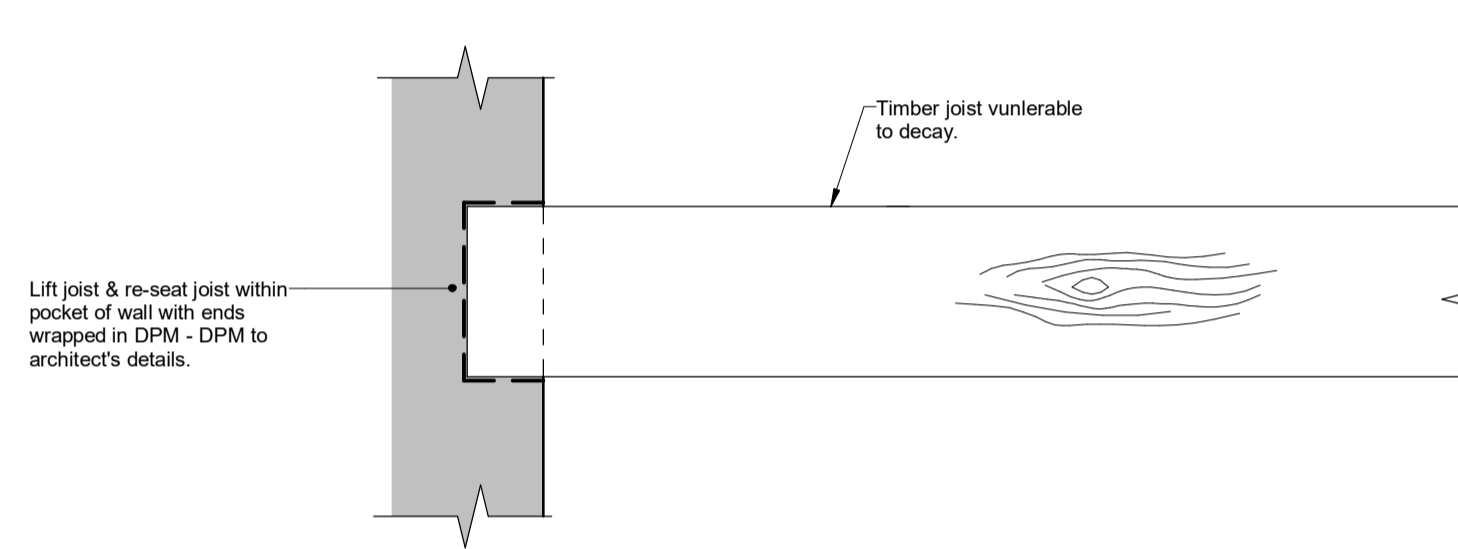

Detail 4: Protection to End of Timber Joist Where Vulnerable to Decay: Option 1
scale 1 : 10

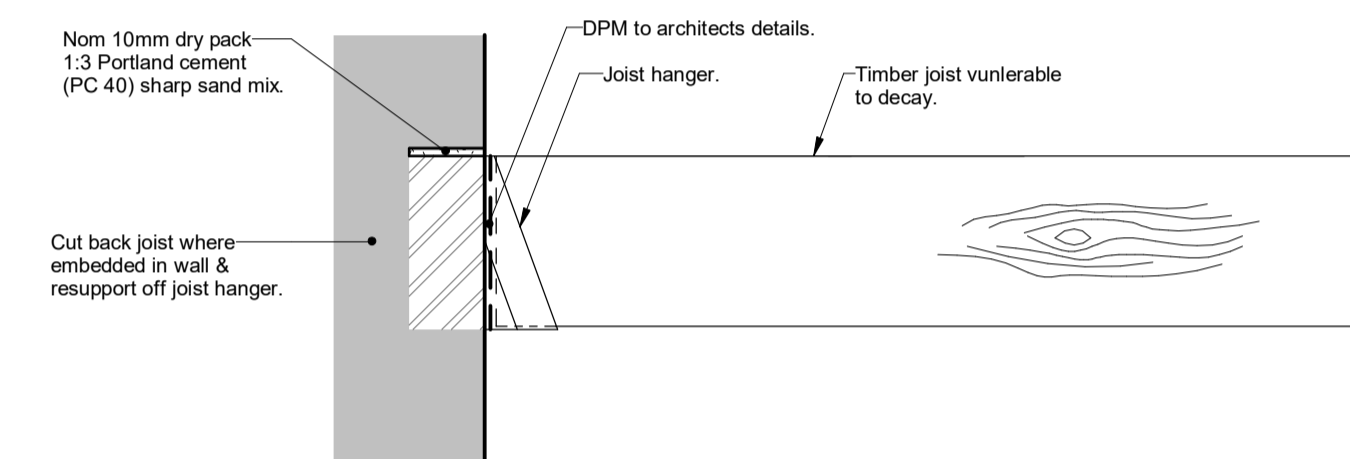

Detail 5: Protection to End of Timber Joist Where Vulnerable to Decay: Option 2
scale 1 : 10

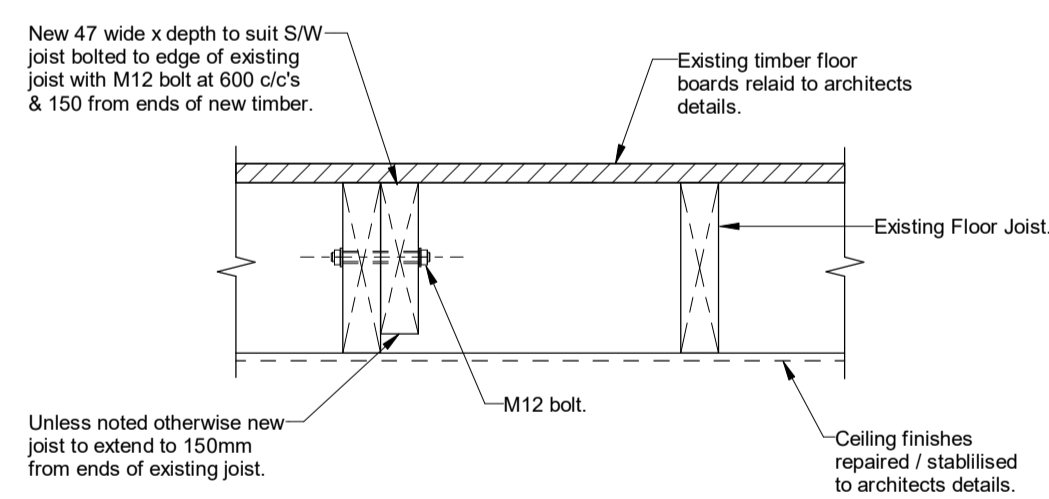

Detail 6: Double Up Floor Joists
scale 1 : 10

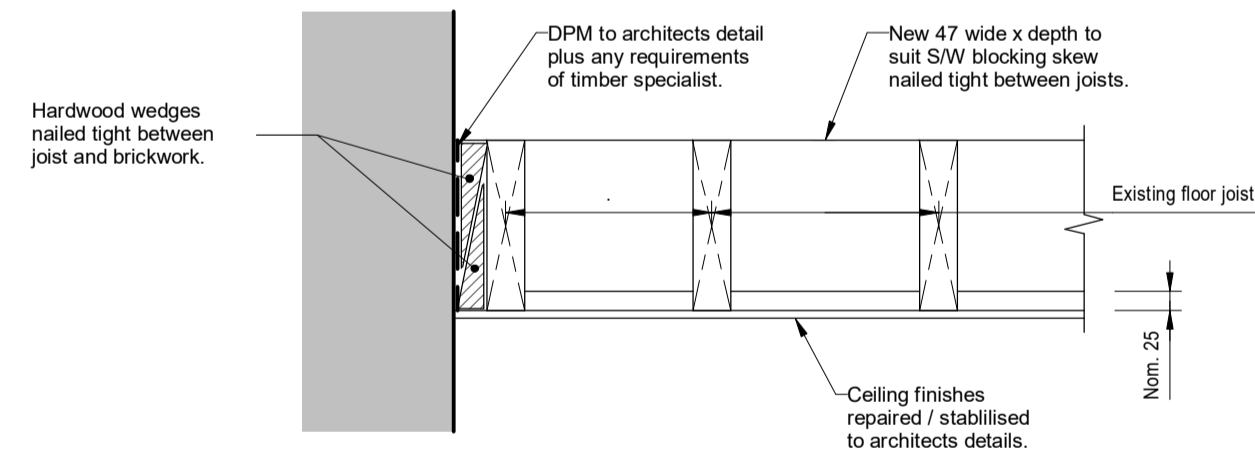

Detail 7: Blocking Between Existing Floor Joist (At Bearing and Mid Span).
scale 1 : 10

REV	DATE	DESCRIPTION	BY	CHKD
B	12.09.16	Issued for Construction.	DA	TP
A	28.07.16	Timber details 2, 4, 5, 6 and 7 updated.	DA	TP
-	15.07.16	First Issue	DA	TP

CONSTRUCTION



TITLE:
Generic Details for Timber Joists Vulnerable/Subject to Decay

PROJECT:
**Project No:11581
Kidderpore Avenue**

SCALE: A1@ 1:10 DATE: July 16 DRAWN: SK CHKD: TP

DRG NO. REV.

9100-DRG-00YY-DE004 B

