

All dimensions to be checked onsite
DO NOT SCALE THIS DRAWING

NOTES

© Copyright CHARLES BRICE LTD

This confidential drawing and the copyright is the property of Charles Brice Ltd and is not to be copied in any way nor disclosed to any third party without the written consent of Charles Brice Ltd.

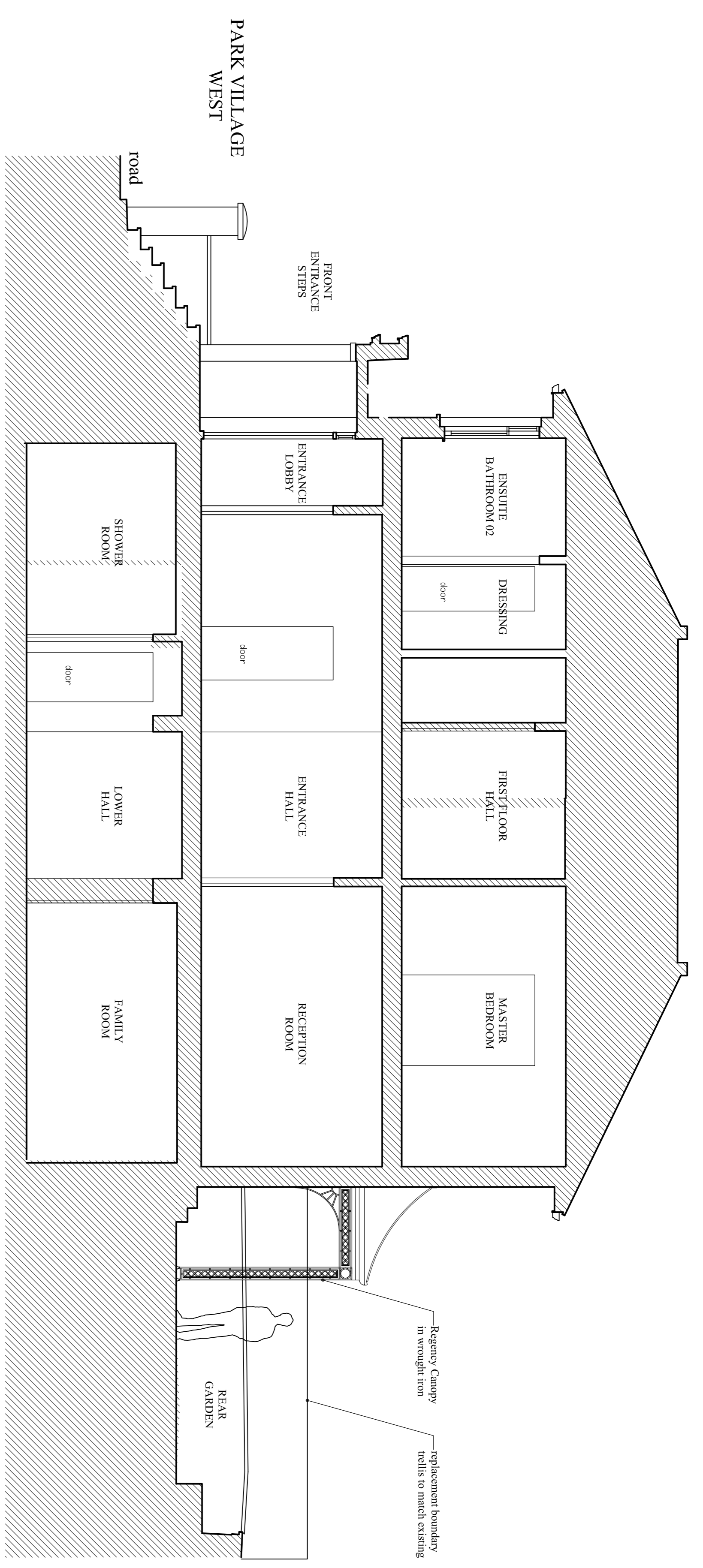

SECTION AA - As Proposed

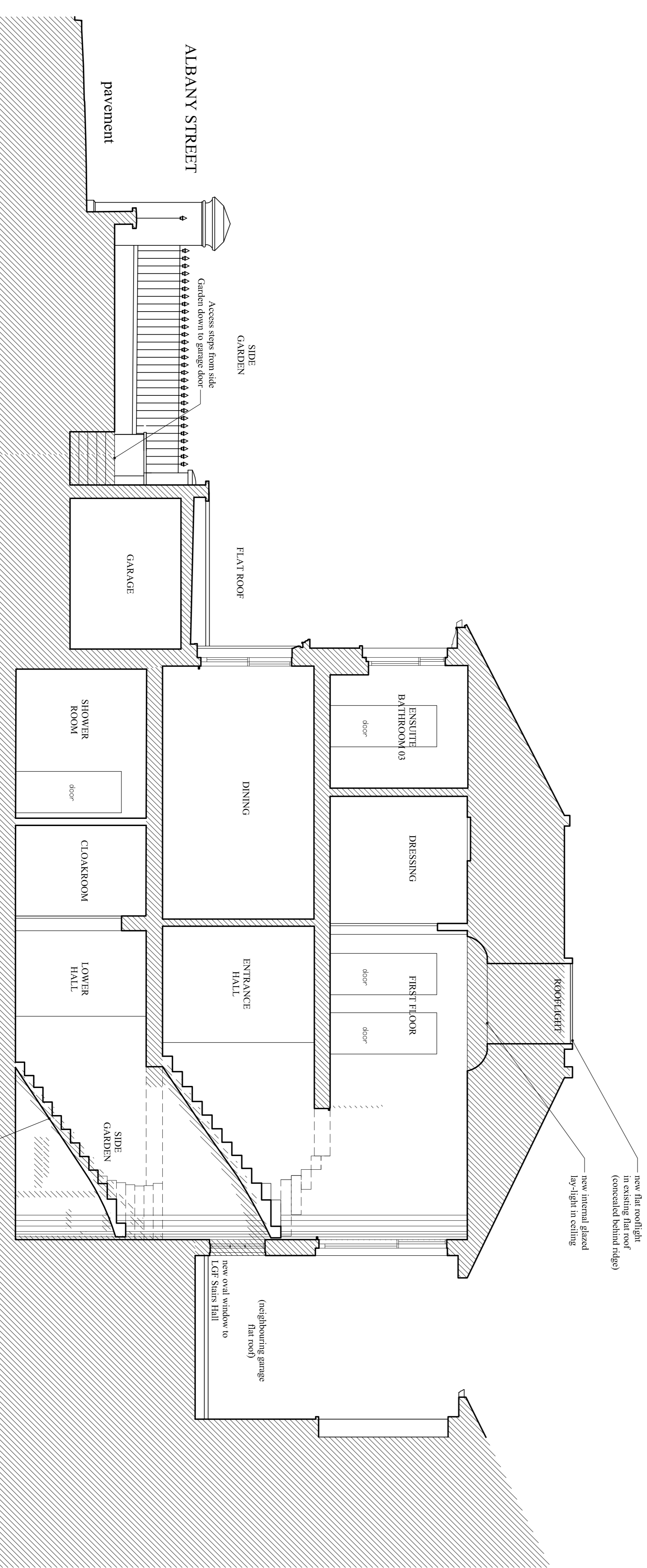
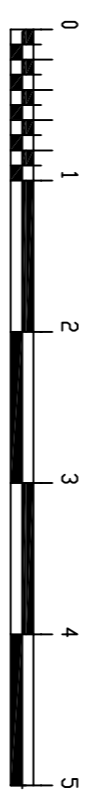

SECTION BB - As Proposed

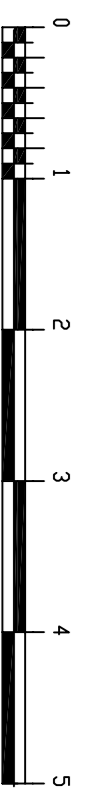

Reference for Section Lines

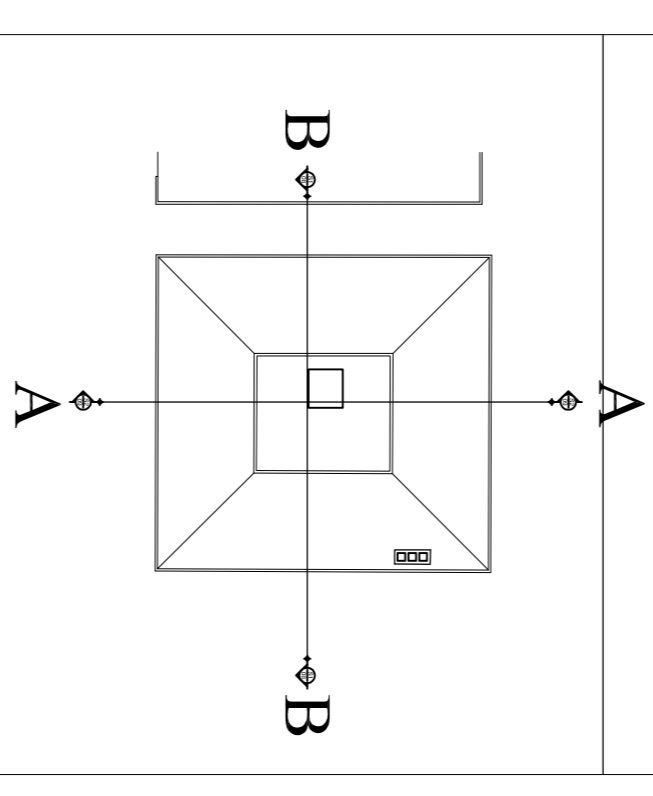

PLANNING

REVISIONS		
B	existing garage width retained & door with external steps added	04.01.17
A	regency-style canopy added	23.05.16

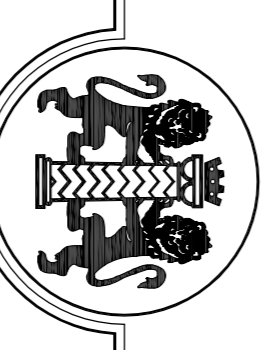

CHARLES BRICE LTD
95 YORK STREET
MARXTLEBONE
LONDON W1H 4QG
Tel: 020 7491 1932 Fax: 020 7491 1952
Email: office@charlesbrice.co.uk
www.charlesbrice.co.uk

Title: Sections AA & BB - As Proposed
Project: 15 Park Village West London NW1 4AE
Client: Mr & Mrs Gurbanov

Scale	Date	Drawn By
1:50@A1	Mar 2016	db
Job Number	Drawing Number	Revision
885	PL07	B