

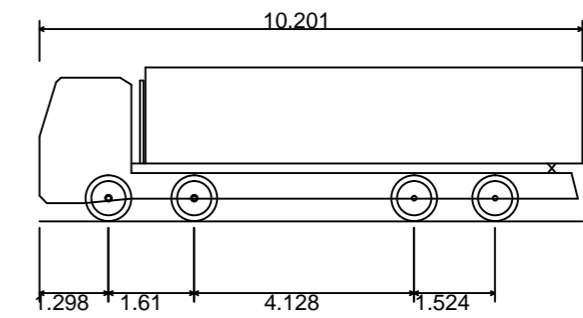

NOTES

1. Do not scale from this drawing.
2. This drawing to be read & printed in colour.
3. This drawing is for illustrative purposes only.

LARGE TIPPER



Overall Length	10.201m
Overall Width	2.495m
Overall Body Height	2.890m
Min Body Ground Clearance	0.341m
Track Width	2.471m
Lock to Lock Time	6.00s
Kerb to Kerb Turning Radius	11.550m

- FORWARD MOVEMENTS ARE SHOWN IN BLACK
(design speed for all forward movements - 5kph)
- REVERSE MOVEMENTS ARE SHOWN IN BLUE
(design speed for all reverse movements - 2.5kph)

Client: **Pegasuslife**

Project: **79 Fitzjohn's Avenue, London**

Drawing Title: **Swept Path Analysis using a Large Tipper - Phase 2 (Wider Road Network)**

Scale: **NTS** Size: **A3**



Woodmace Ltd
 21-23 Willis Way
 Willis Way Ind. Estate
 Poole, Dorset BH15 3SS
 Telephone 01202 667785
 e-mail post@woodmace.co.uk

Rev	Date	Comments