

TYPICAL NEW TRADITIONAL DOOR PLAN SECTION

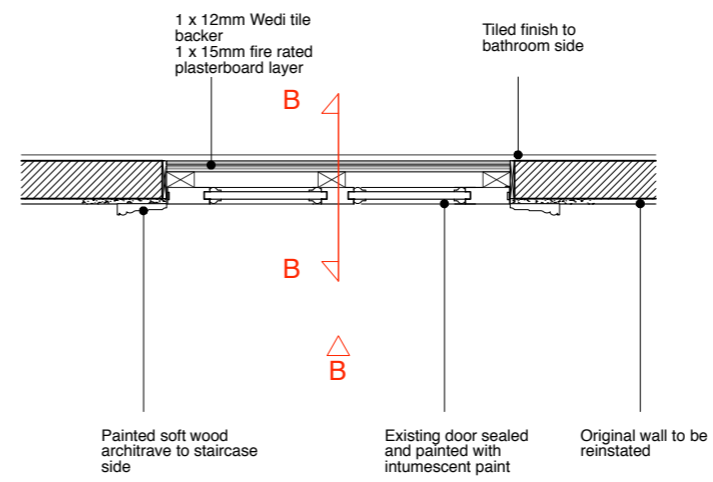

TYPICAL SEALED DOOR PLAN SECTION

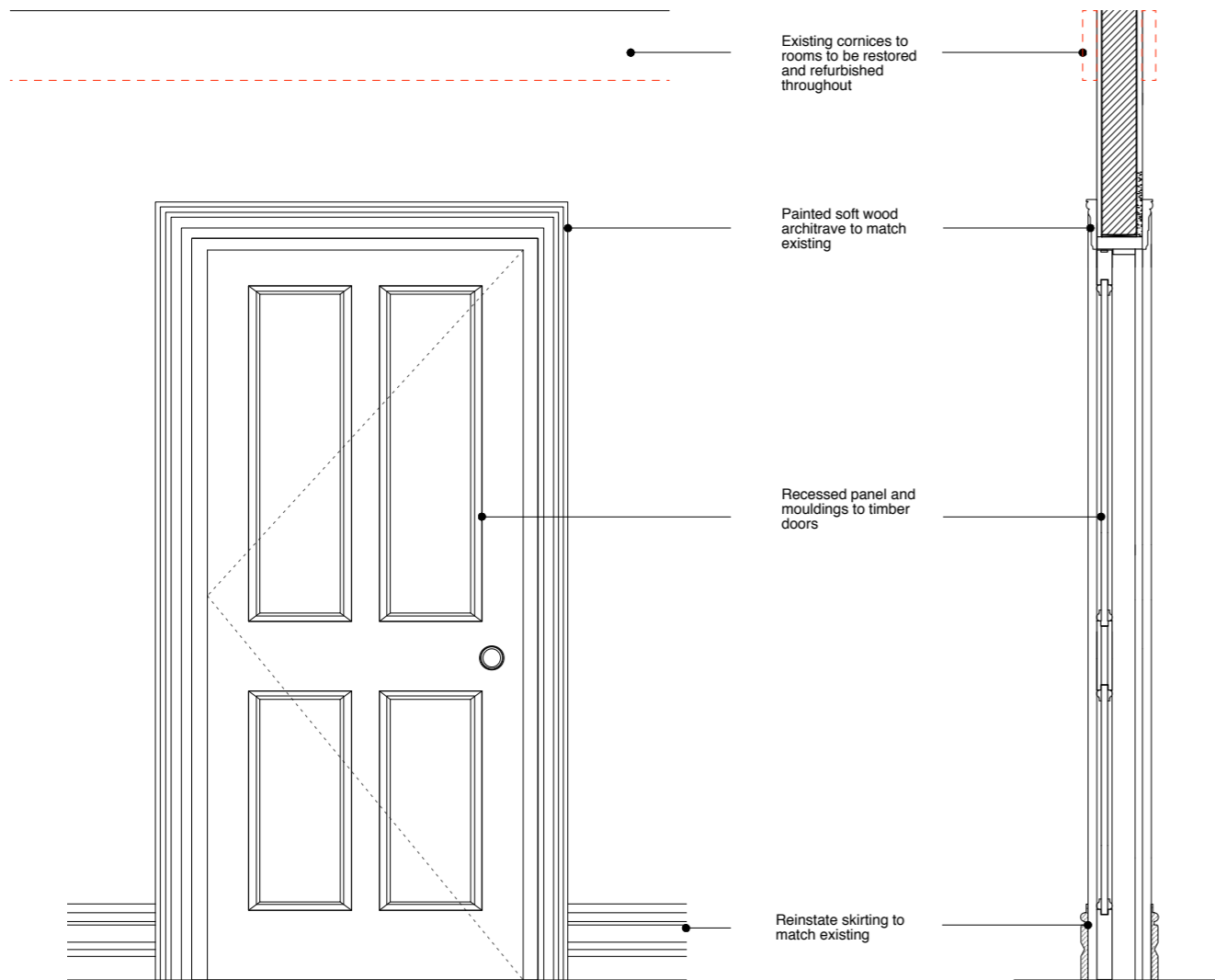

ELEVATION A

SECTION A

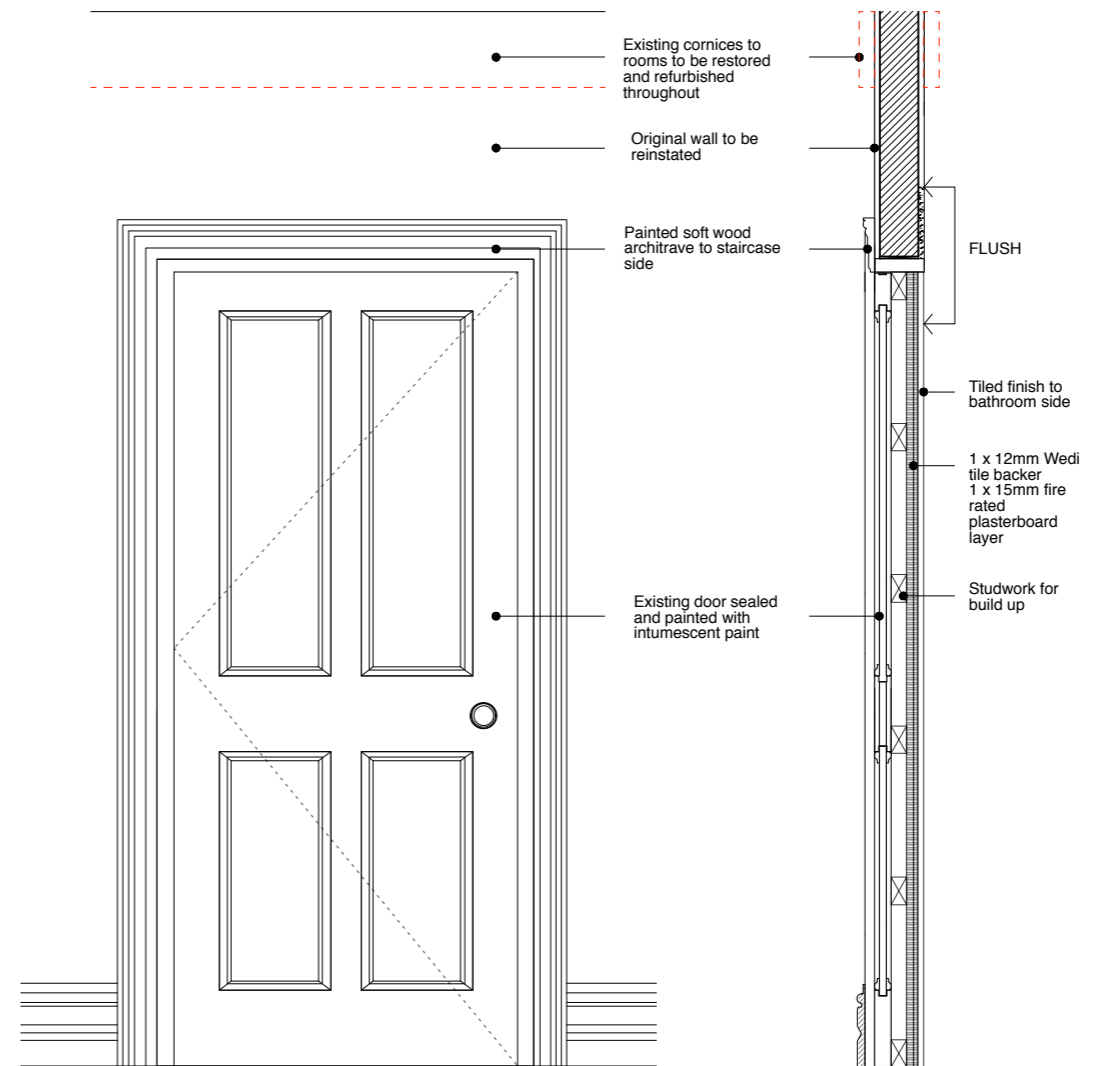

ELEVATION B

SECTION B

GENERAL NOTES:
DO NOT SCALE FROM THIS DRAWING.
ALL DIMENSIONS MUST BE CHECKED ON SITE AND ANY DISCREPANCIES VERIFIED WITH THE ARCHITECT.

P1
20.12.16 - Planning Issue

CLIENT
THE BEDFORD ESTATES

JOB TITLE
27 MONTAGUE STREET LONDON WC1B 5BH

DRAWING TITLE
PROPOSED TYPICAL NEW TRADITIONAL DOOR DETAIL AND EXISTING SEALED DOOR DETAIL

SCALE
1:20 @ A3

DATE
12.16

FT ARCHITECTS LTD

Hamilton House
Mabledon Place
Bloomsbury
WC1H 9BB
020 7953 0388
www.ftarchitects.co.uk

DRAWING No. **319_50_02** REVISION **P1**