

Elevations (External face, 1:20@A3)

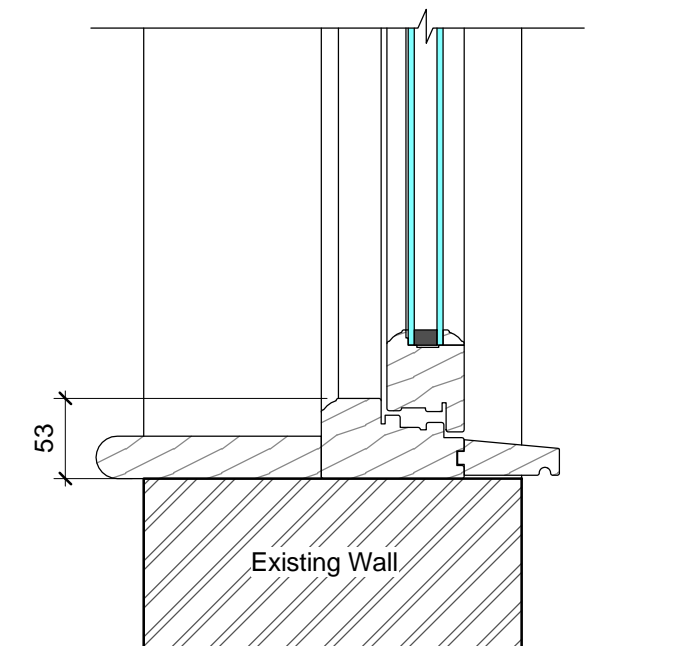
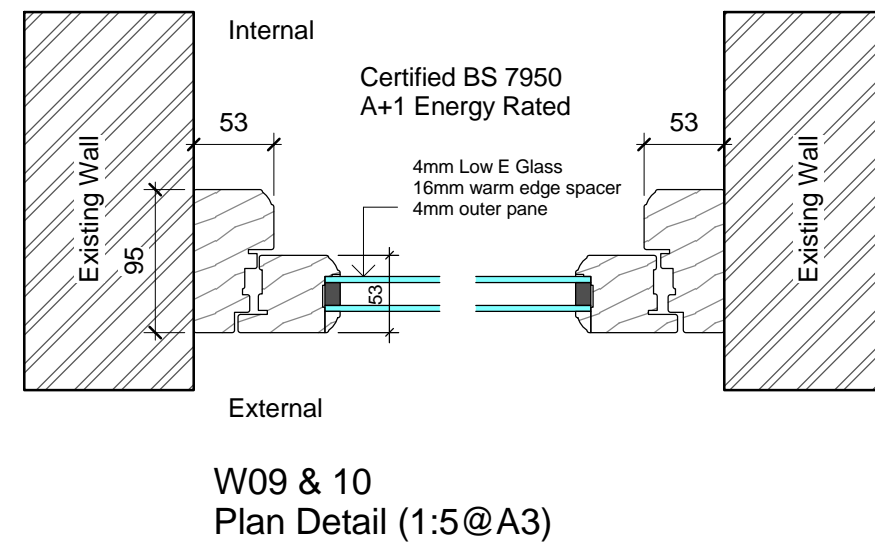

W06, 07, 09 & 10
Section Detail (1:5@A3)

Note

- White painted timber casement windows
- U-value to achieve 1.4 W/m²K or better
- All glazing is double glazed unit
- All windows to have Trickle Vents
- External appearance to match existing
- W09 & 10 to be "Toughened Glass" to both panes of double glazing

Client

MR & MRS COOK

Project title

Ground Floor Flat, 12
Frogna Lane, NW3 7DU

Sheet name

Proposed W06, 07, 09 & 10 -
Elevation, Plan & Section Detail

Ground Floor Flat, 12 Frogna
Lane, Hampstead, NW3 7DU

Planning

Project number 161108

Date 19/DEC/2016

Drawn by LG

Checked by JB

PD-004

Scale

As indicated @

A3

© JAIA
www.jai-a.com