

rbmp_landscape

DESIGN + PLANNING

studio@rbmp.co.uk / www.rbmp.co.uk / +44 (0)1206 515194

Arboricultural Method Statement

2 Hurdwick Place

London NW1 2JE

22nd November 2016

Executive Summary

This report describes the extent and effect of the proposed development at 2 Hurdwick Place London NW1 2JE on 2no. trees adjacent to the site.

The tree was surveyed; using a methodology guided by British Standard 5837:2012 'Trees in relation to design, demolition and construction – Recommendations'.

Subsequently, this report has been produced, balancing the layout of the proposed development against the competing needs of trees. This report comprises all the requisite elements of an arboricultural implications assessment, method statement and supporting plans.

It is the conclusion of this report that the overall quality and longevity of the amenity contribution provided for by the tree on the adjacent site will not be adversely affected as a result of the local planning authority consenting to the proposed development.

General Information

Client: Mr Mark Shooter

Site: 2 Hurdwick Place, London NW1 2JE

Brief proposal description: Excavation of rear garden area to extend existing lower ground floor level, ground floor rear extension with rear balcony, internal alterations to change the layout in association with use as a Hostel.

Tree Survey An arboricultural survey to BS5837 was undertaken by Richard Bennett DipLA CMLI on 16th November 2016.

Limitations: The survey was made at ground level using visual observation only. Detailed examinations, such as climbing inspections and decay detection equipment were not employed.
Scope: Pre-development tree surveys make arboricultural management recommendations based exclusively upon the individual tree or group of trees condition relative to their present context (i.e. not in relation to the proposed development).

Arboricultural Impact Assessment

There are a number of issues that may need to be addressed in an arboricultural impact assessment between the trees and the proposed development, these are as follows:

- The effect and extent of the proposed development within the root protection areas (RPAs) of the tree
- The potential conflicts of the proposed development with the canopy of the tree

These impacts can be seen on the Arboricultural Impact Assessment drawing no. RBMP24-02

Arboricultural Method Statement

Details of key site personnel, including site / project manager will be submitted to the Council's Tree Officer prior to the commencement of site works.

This method statement is to be approved and agreed to in writing by all key personnel prior to the commencement of site works.

Protective measures should be in accordance with this method statement and the Tree Protection Plan; drawing no. RBMP24-03 will remain unaltered and in situ, unless otherwise specified, for the entire duration of the construction.

Phasing of tree protection measures

The tree protection measures shall be phased as follows:

- a) Undertake tree works
- b) Install the protective measures in accordance with the approved protection plans and this method statement
- c) Undertake any demolition works
- d) Undertake and complete construction works
- e) Undertake external landscape works to areas outside of construction exclusion zones
- f) Remove protective measures
- g) Undertake external landscaping works within the construction exclusion zones
- h) Sign off from the company as no further involvement required

Tree Works

For reasons of public safety, all tree works referred to must be carried out prior to any site personnel commencing works or any building materials being delivered.

Summary of Tree Works

No.	Species	Works	Category
1	Ash	Crown reduce/raise to give 2m clearance from proposal.	B2
2	Ash	Crown reduce/raise to give 2m clearance from proposal.	B2

Notes

All tree work is to be undertaken in accordance with British Standard BS 3998:2010, Recommendations for tree work. All arising's are to be removed and the site is to be left as found.

Care is to be taken of the ground around retained trees to make sure that it does not become compacted as a result of tree surgery operations. No equipment or vehicles shall be parked or driven beneath the crowns of any retained trees, to prevent subsequent compaction and root death.

Common Birds

All common wild birds are protected under The Wildlife and Countryside Act 1981. This legislation makes it an offence to:

- Kill, injure or take wild birds.
- Take damage or destroy the nest of wild birds while it is in use or being built.
- Take or destroy the eggs of wild birds.

Certain rare breeding birds are listed on Schedule I of The Wildlife and Countryside Act 1981. Under this legislation they are afforded the same protection as common wild birds and are also protected against disturbance whilst building a nest or on or near a nest containing eggs and or unfledged young e.g. Barn Owl *Tyto alba*.

Bats

Bats species are afforded further protection by the Countryside and Rights of Way Act 2000; and the Natural Environment and Rural Communities Act 2006.

This legislation makes it an offence to:

- Intentionally or deliberately kill, injure or capture bats.
- Deliberately disturb bats, whether at roost or not.

- Damage, destroy or obstruct access to bat roosts.
- Possess or transport bats, unless acquired legally.
- Sell, barter or exchange bats.

A bat roost is defined by the Bat Conservation Trust publication Bat Surveys—Good Practice Guidelines as “the resting place of a bat” (BCT 2007). Generally however, the word roost is interpreted as “any structure or place, which any wild bat uses for shelter or protection.”

Bats tend to re-use the same roosts; therefore legal opinion is guided by recent case law precedents¹, that a roost is protected whether or not the bats are present at the time. This can include for summer roosts, used for breeding; or winter roosts, used for hibernating.

Protective Measures

Protective measures are to be installed immediately following the completion of the tree works, and are to be sited and aligned in accordance with the tree protection plan (RBMP24-03).

Protective Barrier Fencing – See Drawing RBMP24-03

Protective barrier fencing should be appropriate for the intensity and proximity of the development to protect trees where development activity is in close proximity.

Default specification: To comprise either 2.4m wooden site hoarding; or a 2.3m high scaffold framework, well braced to resist impacts, with uprights to be spaced at a maximum of 3.0m intervals and driven into the ground by a minimum of 600mm. Onto this, standard anti-climb welded mesh panels are to be securely fixed to each other with at least two scaffold clamps and to the scaffold frame work with wire.

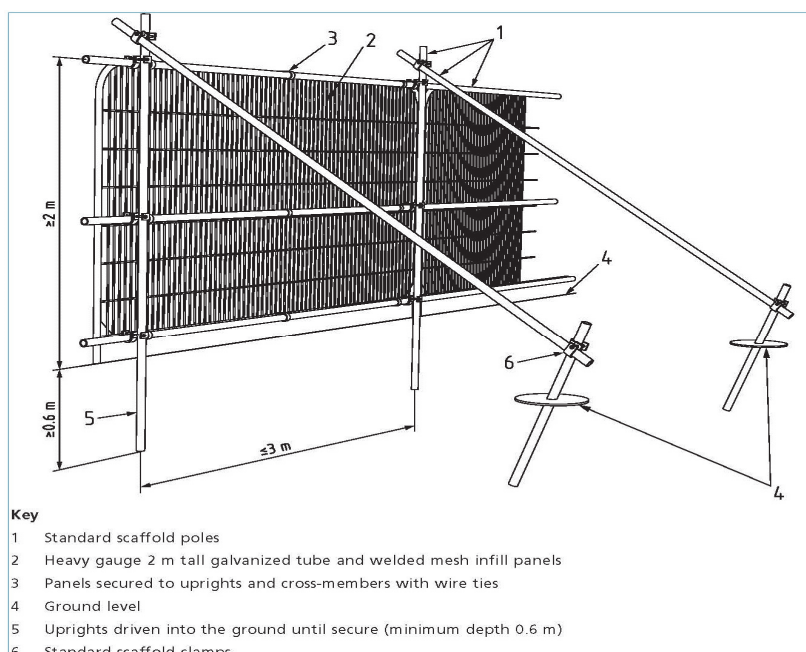

Signage denoting the words “*tree protection area*” at 5.0m intervals should be fixed to the protective barrier fencing (See Appendix 1).

Protective fencing is to be removed ONLY with the written permission of the arboricultural consultant and approval of the local planning authority (LPA).

Site management

The site manager will be responsible for briefing all personnel who will be working within or adjacent to canopies or RPA of the tree and provide or make available to them a copy of this method statement and tree protection plan drawing no. RBMP24-03; this is to include but not exclusively of the movement / operation of plant, excavations, unloading deliveries, mixing / pouring cement and concrete.

The site manager shall designate another person to be in charge of briefing new site personnel or visitors in his absence.

No equipment, vehicles or plant shall operate beyond the tree protection fencing. Booms, hoists and rigs should be kept as far away from the canopies of retained trees at all times. Where it is necessary to operate within 5m of a tree canopy, it will be done with the utmost caution. Damage to trees will be considered a breach of this tree protection plan, which in turn could be a breach of planning permission.

Prohibition

- Mechanical digging or scraping is not permitted within a defined root protection area or within areas cordoned off by protective barrier fencing.
- No access will be permitted within the protected areas;
- No materials, equipment or debris will be stored within any of the fenced areas, or against the fencing;
- Fires are not permitted within 5.0m of any vegetation.
- Leaning objects against or attaching of objects to a tree is not permitted.
- Machinery, plant and vehicles are not permitted to be washed down within 10.0m of vegetation.
- Chemicals and materials are not to be transported, stored, used or mixed within a root protection area or within areas cordoned off by protective barrier fencing.
- Cement silos, mixing site to be situated within a bunded area to prevent pillage/leaking of chemicals harmful to trees. These areas are to be sited well clear of protected trees.
- Refuelling of plant or machinery is prohibited within 10m of the construction exclusion zones.
- It is essential that allowance should be made for the slope of the ground so that damaging materials such as concrete washings, mortar or diesel oil cannot run towards trees.

- Where machinery is to be used within 5m of retained tree canopies a banks man will be required at all times whilst setting up, moving or operating within this area.

Demolition

Prior to the demolition of the existing site features, all tree works are to have been completed, tree protection measures are to be in place as and have been signed off.

Construction

All excavations and construction work within or immediately adjacent to RPAs or canopies of retained trees is to be undertaken under the direct on-site supervision of an arboriculturist.

Existing foundations within the RPA of tree no. 1.

If any new foundations for buildings, structures and hard surfacing are to be situated within the RPA of tree no.1, they are to be designed in conjunction with arboricultural advice to accommodate the likely loading of the structure. The foundations will be designed to limit the amount of excavation required within RPAs to retain roots that are important to the trees stability as identified during the site investigations.

The use of strip foundations within RPAs of retained trees can cause extensive root loss and as such are to be avoided.

Design of foundations for the new dwelling and retaining wall within the RPAs of trees no. 1 are to be designed to minimise the adverse impact upon trees and should pay particular attention to the existing ground levels and proposed finished floor level. Foundation design should be undertaken using site specific information in conjunction with the project arboriculturist and engineer.

Root damage can be minimised using:

- Piles, with a site investigation it is possible to determine their optimal location whilst avoiding damage to roots important for the stability of the tree. Investigative excavations are to be undertaken with the use of hand tools or compressed air displacement to a minimum depth of 600mm;
- Beams laid at or above ground level and or cantilevered as necessary to avoid tree roots identified by the site investigation.

Where piling is to be installed near to trees, the smallest practical pile diameter should be used, as this reduces the possibility of striking major tree roots, and reduces the size of the rig requires to sink the piles. If a piling mat is required, this should conform to the specification for ground boarding. All and any excavations that may be required for foundations within the RPAs of retained trees will initially be undertaken manually under arboricultural supervision (see Manual excavation).

Extension

The foundations should be designed in conjunction with arboricultural advice following site investigations to find suitable depths and locations for the proposed foundations. If piles are to be used the smallest suitable pile size and minimum number are to be used.

Any piling rig should be situated outside of any RPAs of the retained trees or on top of ground boarding designed by the project engineer capable of dealing with the likely loading.

Patio

New hard surfacing for the patio is partially situated within the RPA of tree no. 1 & 2 and due to the incursion the proposed will be excavated manually where it enters within the RPAs (see Manual excavation).

Manual excavation technique

Excavation within RPAs will be undertaken by hand under direct on-site arboricultural supervision of the required depth of the foundation; Or to a minimum of 600mm deep of any excavation, whether for proposed foundations, hard surfacing or underground services. The total depth of the manual excavation will be determined by the arboriculturist whilst on site.

The soil is to be loosened with the aid of a fork or pick axe and then cleared with the aid of an Air-spade, Air-vac and or shovel. Any roots found will be cleanly severed with either a hand saw or secateurs.

Any roots found with a diameter of less than 25mm shall be cleanly severed by the arboricultural consultant. Any roots of 25mm and above shall be excavated around without damaging them; the arboricultural consultant shall decide if it's feasible or necessary to retain the root, if not it shall be severed.

The edge of the excavation closest to the trees will be covered with damp hessian to prevent soil collapse or contamination by concrete.

Soil beneath the depth may be sheet piled, regular piled or excavated deeper. Machinery may be used for this providing that it is situated outside of the RPA or has appropriate ground protection in place to move around on and work upon.

Broken Trench – Hand Dug

This technique combines both trenchless techniques and manual excavation where excavation is unavoidable. Excavations should be limited to where there is clear access around and below the roots. All trenches are to shall be excavated by hand with the same precautions taken as for manual excavation. Open section of trench should only be large enough to allow access for linking to the next section.

Concrete foundations

Prior to concrete being poured to form the foundations within or immediately adjacent to the RPAs of retained trees the excavation is to be lined and sealed to prevent any leaching of the concrete into the soil and causing desiccation of retained roots by concrete run off.

Limitations

RBMP Ltd has prepared this Report for the sole use of the above named Client/Agent in accordance with our terms of business, under which our services were performed. No other warranty, expressed or implied, is made as to the professional advice included in this Report or any other services provided by us. This Report may not be relied upon by any other party without the prior and express written agreement of RBMP Ltd. The assessments made assume that the sites and facilities will continue to be used for their current purpose without significant change. The conclusions and recommendations contained in this Report are based upon information provided by others and upon the assumption that all relevant information has been provided by those parties from whom it has been requested. Information obtained from third parties has not been independently verified by RBMP Ltd.

Copyright

© This Report is the copyright of RBMP Ltd.

APPENDIX ONE
Tree Survey Schedule

Tree Survey Schedule, 22nd November 2016

Tree Number	Species	Height	Stems		Crown		Age	RP (area/radius)m ²	Condition	Preliminary Recommendations	Category ERC
			No	Ø (mm)	Spread (m)	Clear (m)					
T1	Ash (Fraxinus excelsior)	20	2	800	N - 5	4	EM	40/varies	C - Fair S - Fair B - Fair	Tree in neighbouring property, close to building with crown spread over site	B2
				600	E - 3	4					
					S - 4	4					
					W - 5	4					
T2	Ash (Fraxinus excelsior)	20	1	600	N - 2	4	EM	27/2.5	C - Fair S - Fair B - Fair	Tree in neighbouring property, close to building with crown spread over site	B2
					E - 6	4					
					S - 3	4					
					W - 1	4					

APPENDIX TWO

Associated Drawings:

- **RBMP24-01, TREE SURVEY**
- **RBMP24-02, ARBORICULTURAL IMPACT ASSESSMENT**
- **RBMP24-03, TREE PROTECTION PLAN**

All dimensions should be checked on site. No dimensions are to be scaled from this drawing. Please notify rbmp Ltd. of any discrepancies found. rbmp Ltd. cannot be held responsible for inaccuracies in the base drawing in which this plan is based. This drawing is designed to reflect the principles of the layout or design only, and relates only to the protection of retained trees.

This drawing was produced in colour - a monochrome copy should not be relied upon.

rbmp ltd. 2016

Tree Number	Species	Height	Stems		Crown		Age
			No	Ø (mm)	Spread (m)	Clear (m)	
T1	Ash (Fraxinus excelsior)	20	2	800	N - 5	4	EM
					E - 3	4	
					S - 4	4	
					W - 5	4	
T2	Ash (Fraxinus excelsior)	20	1	600	N - 2	4	EM
					E - 6	4	
					S - 3	4	
					W - 1	4	

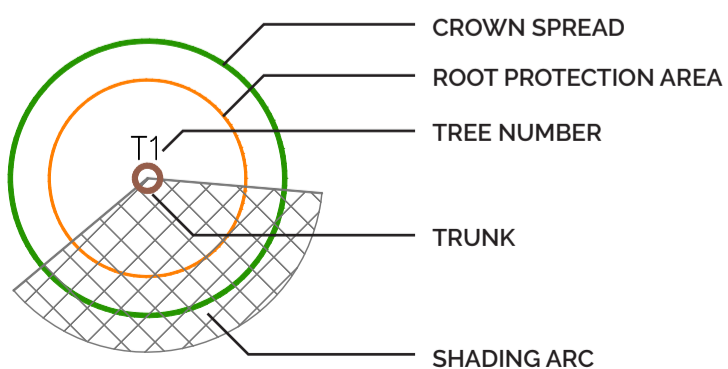
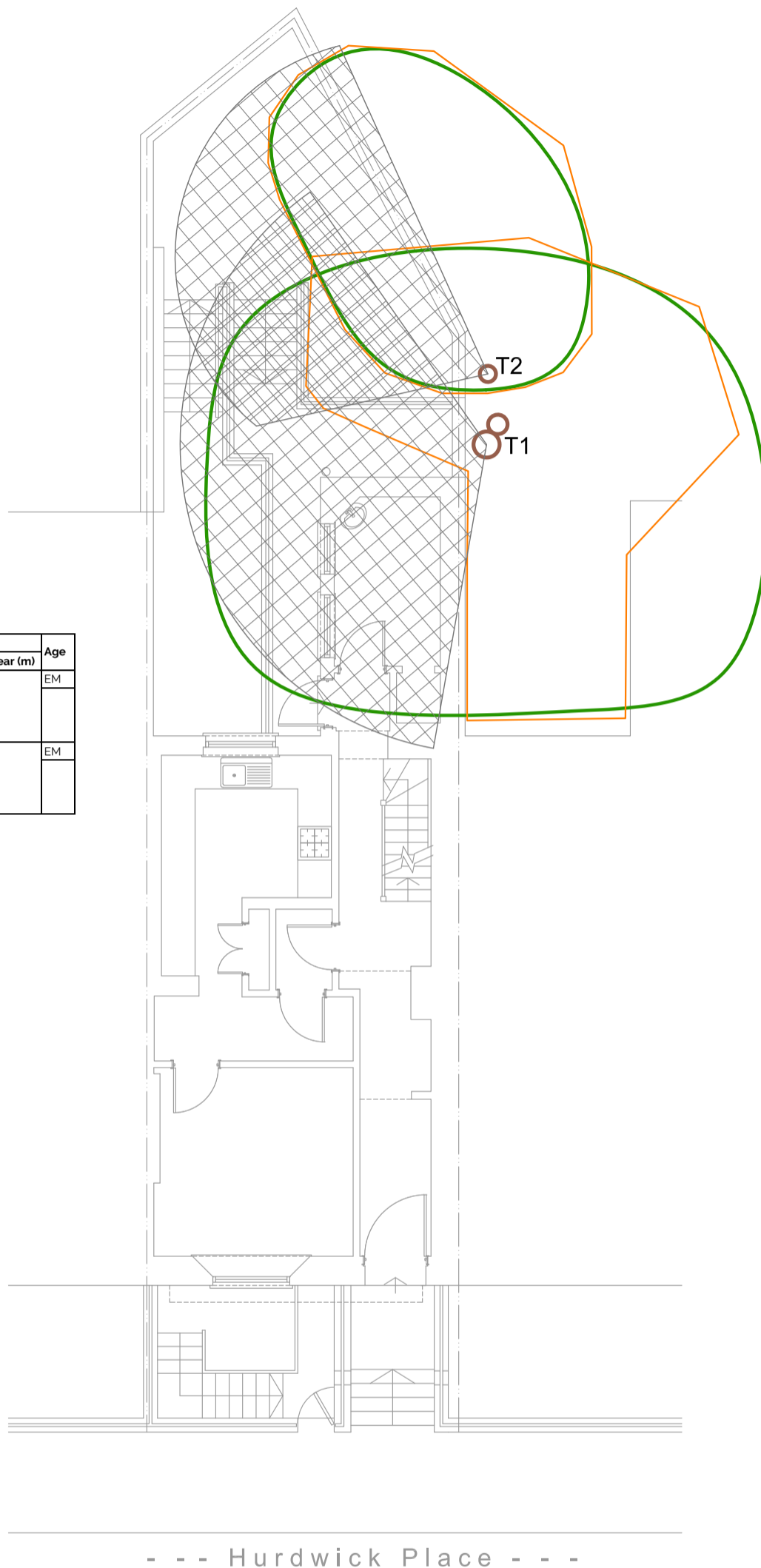

TREE SURVEY
2 HURDWICK PLACE
 RBMP24-01 22nd November 2016

rbmplandscape

DESIGN + PLANNING
 studio@rbmp.co.uk / www.rbmp.co.uk / +44 (0)1206 515194

© rbmp ltd.

All dimensions should be checked on site. No dimensions are to be scaled from this drawing. Please notify rbmp Ltd. of any discrepancies found. rbmp Ltd. cannot be held responsible for inaccuracies in the base drawing in which this plan is based. This drawing is designed to reflect the principles of the layout or design only, and relates only to the protection of retained trees.

This drawing was produced in colour - a monochrome copy should not be relied upon.

rbmp Ltd. 2016

NOTES

TREE CATEGORIES

Trees are categorised in accordance with the cascade chart in Table 1 of the British Standard BS 5837:2005 'Trees in relation to construction - Recommendations'

T1 - Category 'B'

T2 - Category 'B'

'B' - Trees of moderate quality with an estimated remaining life expectancy of at least 20 years.

ROOT PROTECTION AREA

The RPA is calculated using the British Standard BS 5837:2012 'Trees in relation to design, demolition and construction - Recommendations.'

TREE WORKS

All tree work is to be undertaken in accordance with British Standard BS 3998:2010 Tree work - Recommendations.

All arisings are to be removed and the site is to be left as found. Care is to be taken of the ground around retained trees to make sure that it does not become compacted as a result of tree surgery operations. No equipment or vehicles such as timber lorries, tractors, excavators or cranes shall be parked or driven beneath the crowns of any retained trees, to prevent subsequent compaction and root death.

ARBORICULTURAL METHOD STATEMENT

All tree work is to be undertaken in accordance with British Standard Please refer to Arbtech Consulting Ltd. Tree Schedule, Arboricultural Method Statement and Tree Protection Plan, for full details on all surveyed trees and how all aspects of the development maybe implemented without detriment to retained trees.

FOUNDATIONS WITHIN RPAs

The use of traditional strip foundations can result in excessive root loss and as such should be avoided.

Designs for foundations that would minimize the adverse impact upon trees should include particular attention to the existing levels, proposed finished levels and cross sectional details. Site specific and specialist advice should be sought from the project engineers and arboriculturist.

Root damage can be minimized by using:

- Piles with site investigation used to be determined their optimal location whilst avoiding damage to roots important for the stability of the tree, by means of hand tools or compressed air soil displacement, to a minimum depth of 600mm;
- Beams, laid at or above ground level, and cantilevered as necessary to avoid tree roots identified by site investigation.

Where a slab for minor structures (e.g. shed base) is to be formed within the RPA, it should bear on the existing ground level, and should not exceed an area greater than 20% of the existing unsurfaced ground.

HARD SURFACING WITHIN RPAs

Existing vegetation may be removed with hand tools or sprayed with an approved non residual herbicide such as 'Glyphosate'. The new hard surfacing will be constructed using a 'No Dig' surfacing situated entirely above the existing soil surface and where needed using a proprietary cellular confinement system (GeoWeb or similar) laid over a bi-axel geo-grid (tensar TriAx or similar). Prior to this any small hollows on the surface may be filled with clean sharp sand (not builders sand) to a maximum depth of 150mm. The 'GeoWeb' is to be back filled by hand with a no-fines aggregate of 20mm - 30mm. The area of 'GeoWeb' will be covered with a permeable geotextile fabric and the finished wearing course laid on top. Edge supports of an appropriate size and strength should be set above ground level and secured with haunching or steel pins driven into the ground. the outer edge of the supports may be banked up with clean top soil.

This information is compliant with British Standard BS5837:2012 Trees in relation to design demolition and construction - Recommendations, section 7.5 Special engineering for foundations within the RPA.

ISSUE: Proposed patio is partially situated within the RPA.

SOLUTION: Proposed patio is to be designed with the aid of arboricultural advice and trial excavations to determine the presence and location of any tree roots.

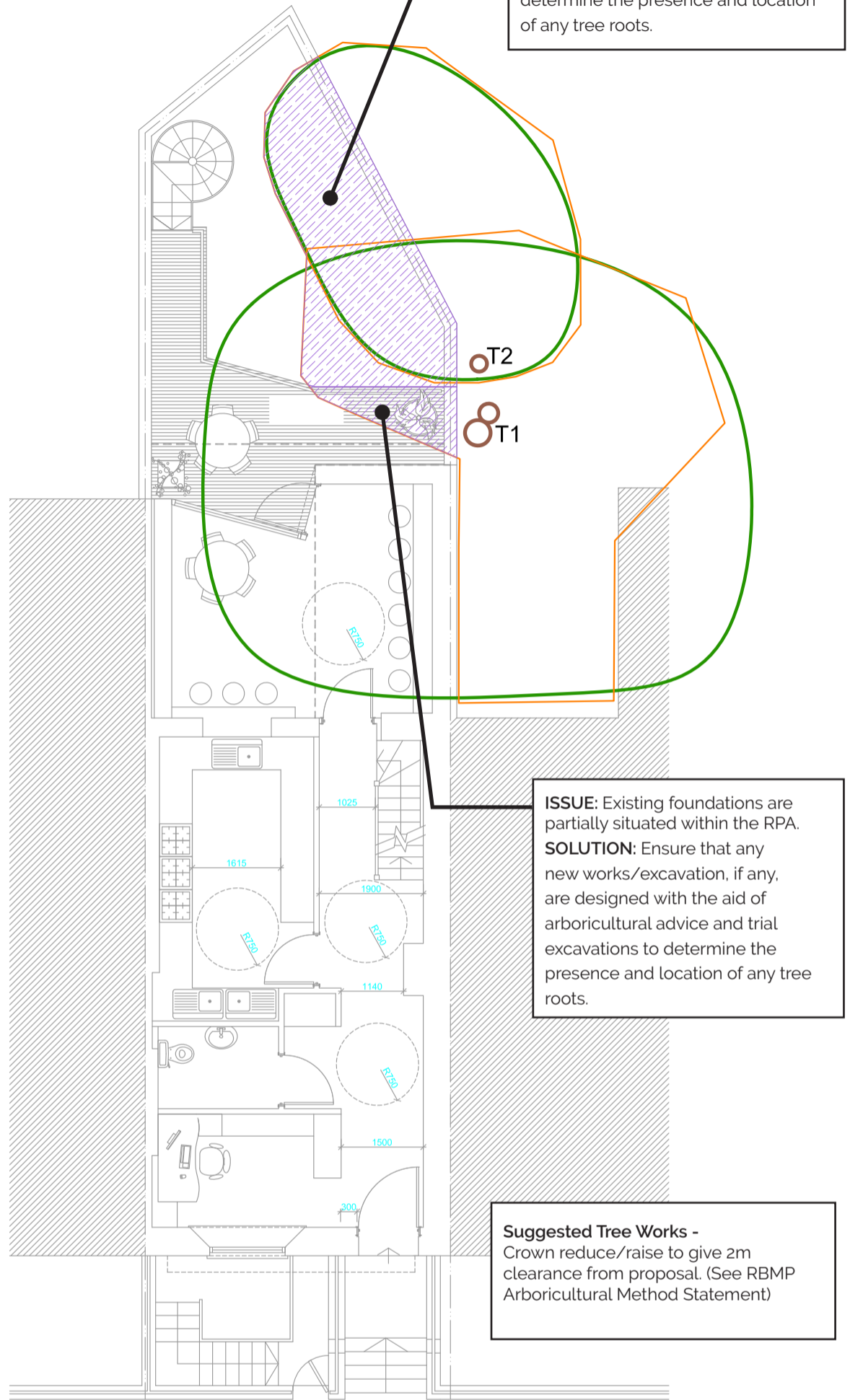

ISSUE: Existing foundations are partially situated within the RPA.

SOLUTION: Ensure that any new works/excavation, if any, are designed with the aid of arboricultural advice and trial excavations to determine the presence and location of any tree roots.

Suggested Tree Works -
Crown reduce/raise to give 2m clearance from proposal. (See RBMP Arboricultural Method Statement)

- - - Hurdwick Place - - -

KEY

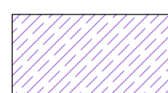

INCURSION

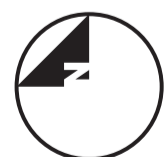

1.100@A3

ARBORICULTURAL IMPACT ASSESSMENT

2 HURDWICK PLACE

RBMP24-02 22nd November 2016

rbmplandscape

DESIGN + PLANNING

studio@rbmp.co.uk / www.rbmp.co.uk / +44 (0)1206 515194

© rbmp Ltd.

All dimensions should be checked on site. No dimensions are to be scaled from this drawing. Please notify rbmp ltd. of any discrepancies found. rbmp Ltd. cannot be held responsible for inaccuracies in the base drawing in which this plan is based. This drawing is designed to reflect the principles of the layout or design only, and relates only to the protection of retained trees.

This drawing was produced in colour - a monochrome copy should not be relied upon.

rbmp ltd. 2016

SUPERVISED EXCAVATION

Excavation adjacent to RPAs are to be undertaken under direct on-site arboricultural supervision. Excavation will consist of a mixture of mechanical and manual excavation.

Initial excavation will be undertaken by hand under to a minimum of 200mm deep of any excavation, the soil is to be loosened with the use of a fork or pick and then cleared with the aid of an air-spade, air-vac or shovel. There after excavation can be undertaken using an excavator with a suitably sized toothless grading bucket using a grading motion rather than digging and taking no more than 10 - 20mm deep swipes at any time, if any roots are discovered mechanical excavation will be stopped immediately and manual excavation will resume to expose the root. All roots to be cut will be cleanly severed with the use of a hand saw or secateurs. The edge of the excavation closest to the retained trees will be covered over with damp hessian to prevent drying out, and where necessary be shuttered to prevent soil collapse or contamination by concrete. If appropriate soil beneath the depth 750mm may be sheet piled, regular piled or individual piles. Any deeper excavations may be undertaken by a machine provided it works form outside of the RPA or has appropriate ground protection in place to move and work upon.

GROUND BOARDING

New temporary ground protection should be capable of supporting any traffic entering or using the site without being distorted or causing compaction of underlying soil.

Note The ground protection might comprise one of the following:

- for pedestrian movements only, a single thickness of scaffold boards placed either on top of a driven scaffold frame, as to form a suspended walkway, or on top of a compression-resistant layer (e.g. 100mm depth of woodchip), laid onto a geotextile membrane;
- for pedestrian-operated plant up to a gross weight of 2t, proprietary inter-linked ground protection boards placed on top of a compression-resistant layer (e.g. 150mm depth of woodchip), laid onto a geotextile membrane;
- for wheeled or tracked construction traffic exceeding 2 t gross weight, an alternative system (e.g. proprietary system or pre-cast reinforced concrete slabs) to an engineering specification designed in conjunction with arboricultural advice, to accommodate the likely loading to which it will be subjected.

PROTECTIVE FENCING

To be erected prior to the commencement of all works on site, and retained in place throughout construction. (see image)

Default specification: To comprise either 2.4m wooden site hoarding; or a 2.3m high scaffolding framework comprising of vertical and horizontal framework, well braced to resist impacts, with uprights to be spaced at a maximum of 3.0m intervals and driven into the ground by a minimum of 600mm. On to this, standard anti-climb welded mesh panels are to be securely fixed to each other with at least two scaffold clamps and to the scaffold framework with wire. Secondary Specification: To comprise of 2m tall welded mesh panels on rubber or concrete feet. Panels are to be joined together using a minimum of two anti-tamper couplers, installed so that they can only be removed from inside the fence. The panels should be supported on the inner side by stabilizer struts, which should be attached to a base plate and secured with ground pins. All weather notices should be erected at regular intervals on the weld mesh panels with words such as "Construction exclusion zone - Keep out".

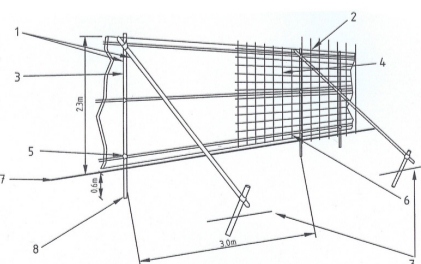

Please refer to RBMP Ltd. Tree Schedule and Arboricultural Method Statement, for full details on all surveyed trees and how all aspects of the the development maybe implemented without detriment to retained trees.

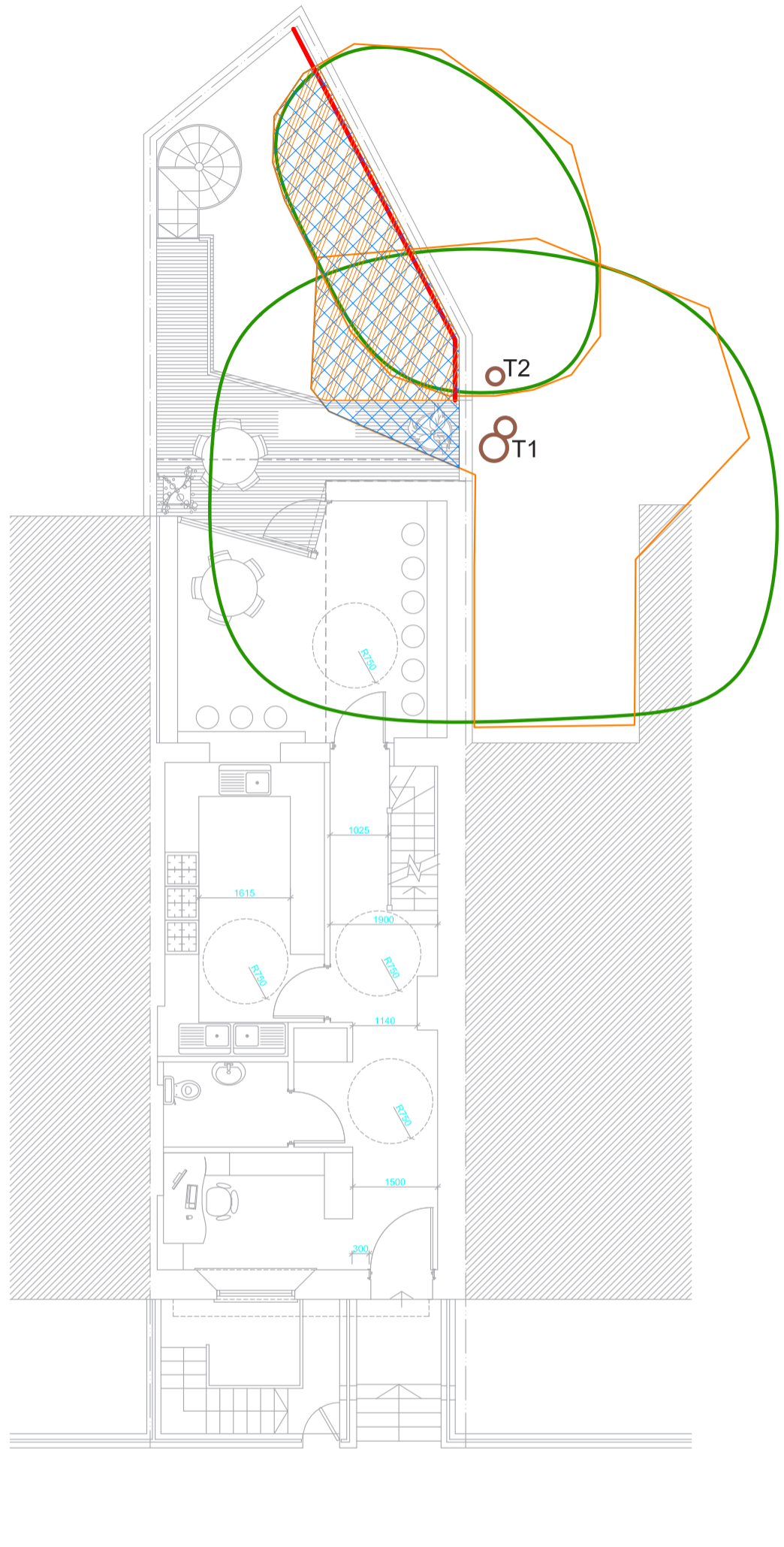

An arboricultural consultant will be required to attend site to supervise:

- Location of protective measures.
- Manual excavation for foundations

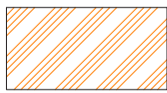

- - - Hurdwick Place - - -

KEY (see notes)

-  SUPERVISED EXCAVATION
-  GROUND BOARDING
-  PROTECTIVE FENCING

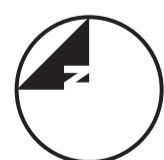

1.100@A3

TREE PROTECTION PLAN

2 HURDWICK PLACE

RBMP24-03 22nd November 2016

rbmplandscape

DESIGN + PLANNING

studio@rbmp.co.uk / www.rbmp.co.uk / +44 (0)1206 515194

© rbmp ltd.