

The contractor is responsible to ensure that no products are to be utilised that do not comply with relevant British and/or European Standards and/or Codes of Practice, Codes of Regulation, construction regulations, or which are known or suspected at the time of product selection, to be in compliance with the relevant building regulations and to be suitable for the work or not in accordance with good building practices.

The contractor is responsible for checking dimensions, tolerances, levels and references. The contractor is responsible for ensuring that the drawings are in accordance with the drawings on site or shop drawings.

Where an item is covered by drawings to different scales, the larger scale drawing is to be worked to.

Do not scale drawings. Figured dimensions to be worked to in all cases.

This drawing and the copyright and patents therein are the property of Bally Garner LLP and may not be used or reproduced without consent or attribution.

Notes.

- System:**
 Dualframe 75Si casement window
 Outer frame = DF1409
 Vent profile = DF1412
 Mullion = DF1403
 Transom = DF1409
 Sill = UF513
 Trickle vent profile = UF508

For Further information contact:
 Sapa Building System on
 01684 853500

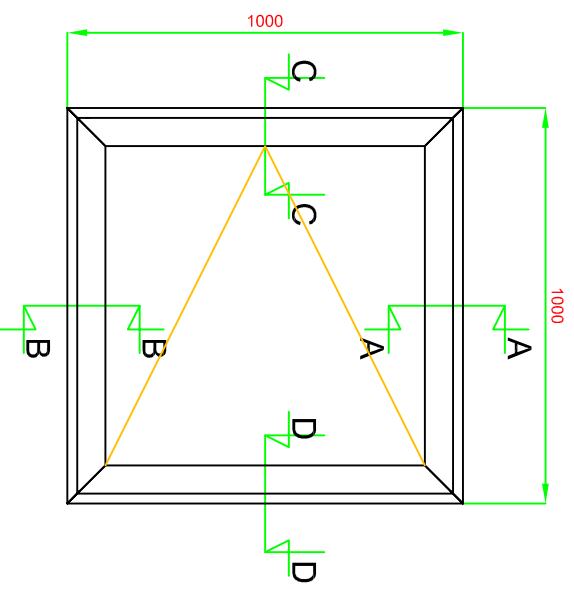

External Elevation

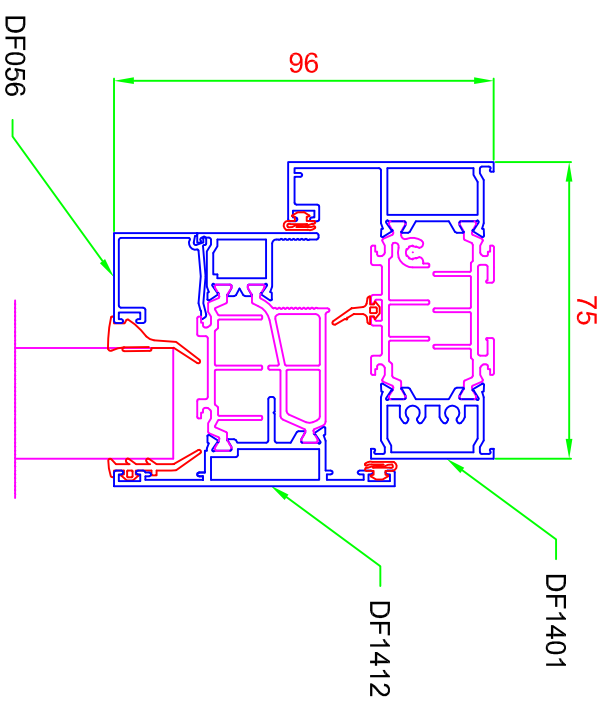

Section AA

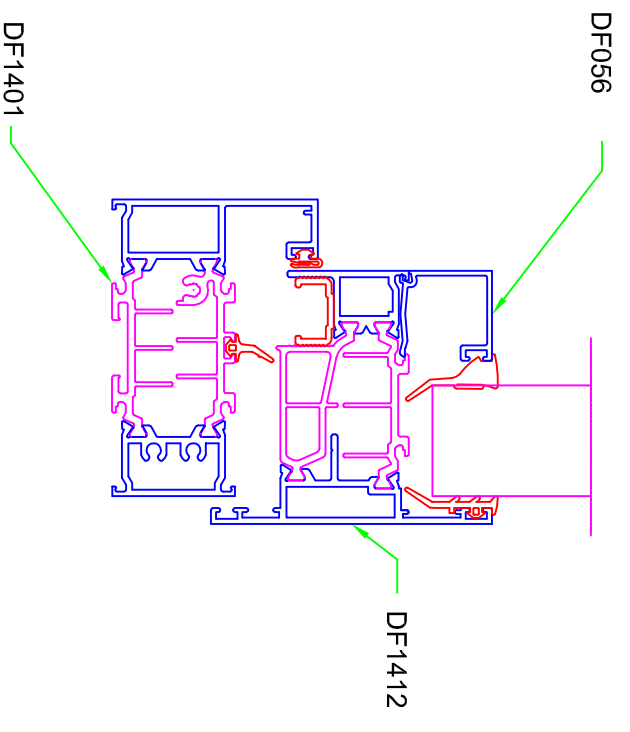

Section BB

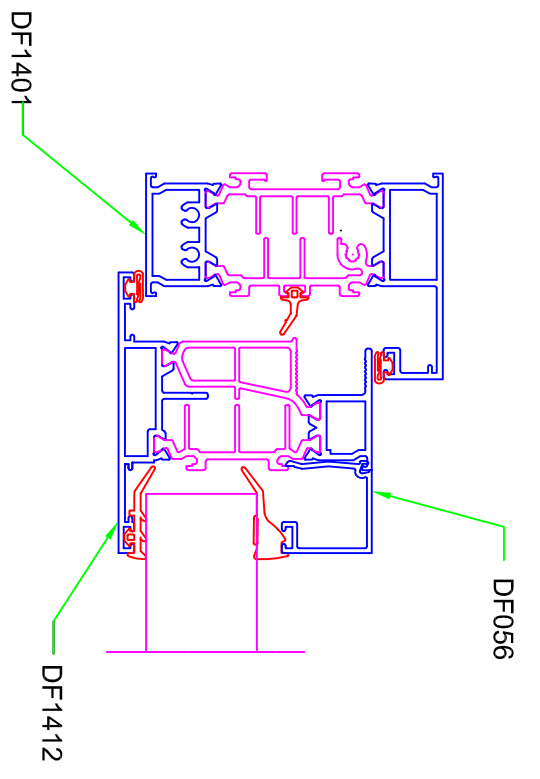

Section CC

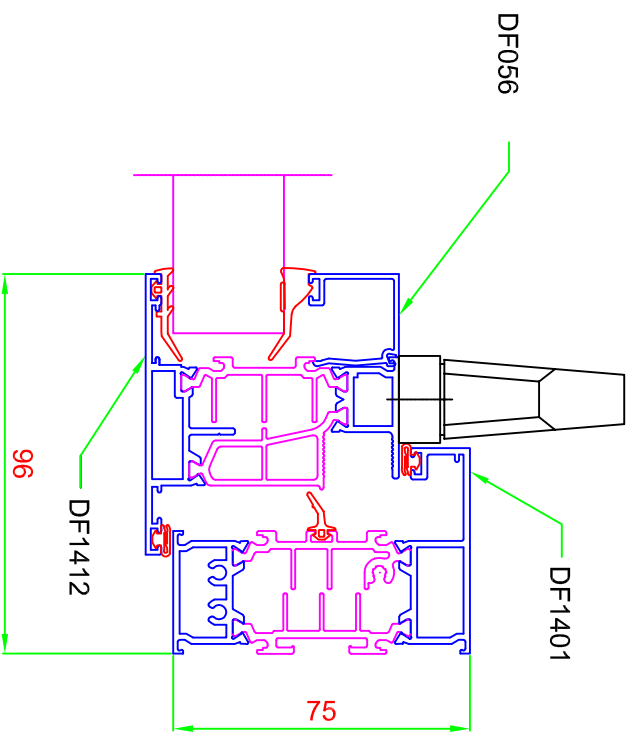

Section DD

26893- Bourne Estate: Gooch Buildings

Proposed Elevation & Cross Sections

CLIENT: London Borough of Camden	PROJECT: 26893- Bourne Estate
ADDRESS: Gooch Buildings London EC1N 7SE	TITLE: Dualframe - Type 4
SCALE: 1:20 & 1:2	PURPOSE OF ISSUE: Planning
JOB NO.: 26893	DATE: 26/11/2016
REVISION: P P04	REVISION:

