

- NOTES**
1. THIS DRAWING IS TO BE READ IN CONJUNCTION WITH ALL OTHER ENGINEERS AND ARCHITECTS DRAWINGS AND SPECIFICATIONS.
 2. FOR GENERAL NOTES REFER TO 2201-S-001/003.
 3. ALL DIMENSIONS SHOWN ARE IN MILLIMETRES UNLESS NOTED OTHERWISE.
 4. DO NOT SCALE FROM THIS DRAWING.

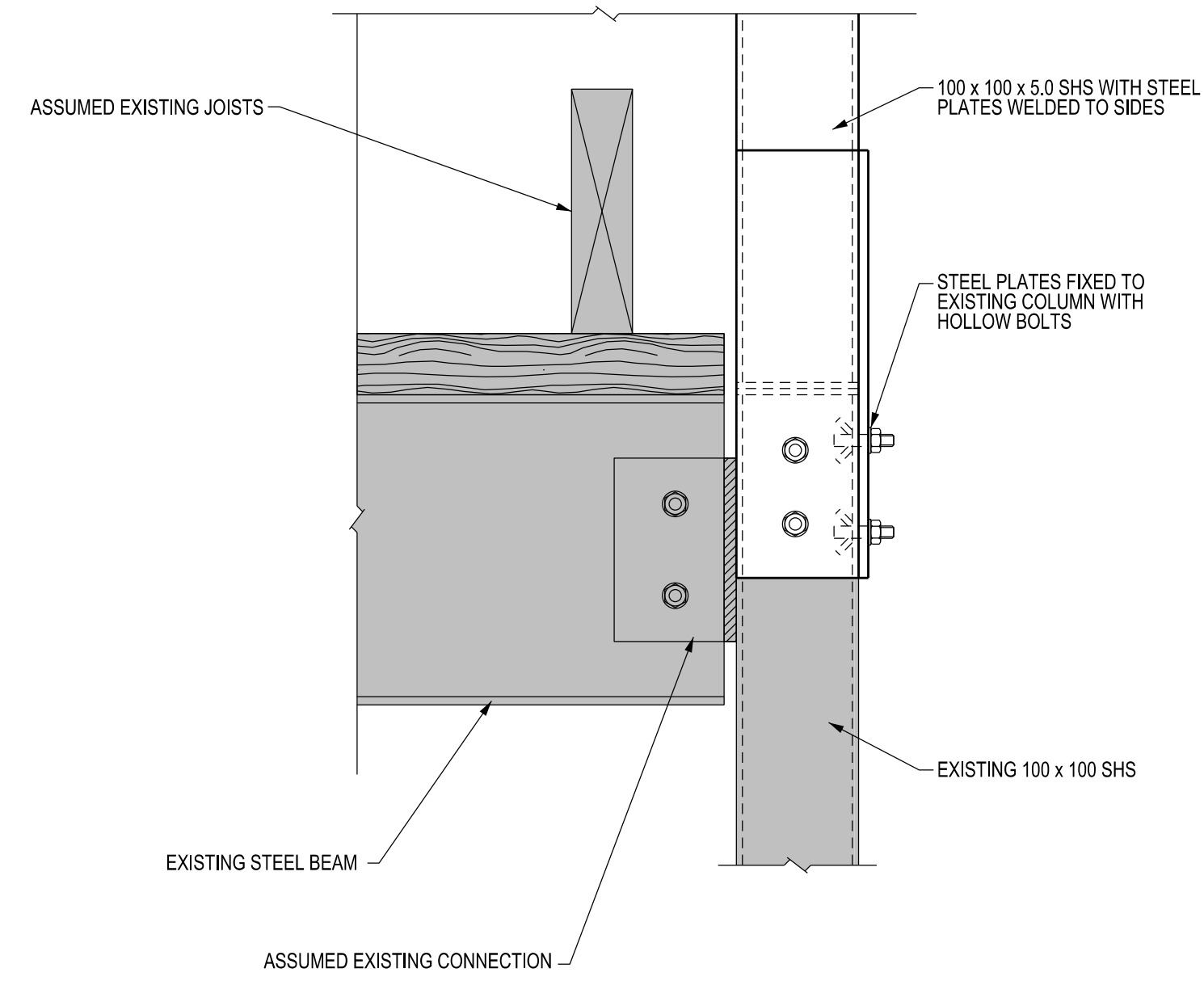

SECTION **F1**
S-100

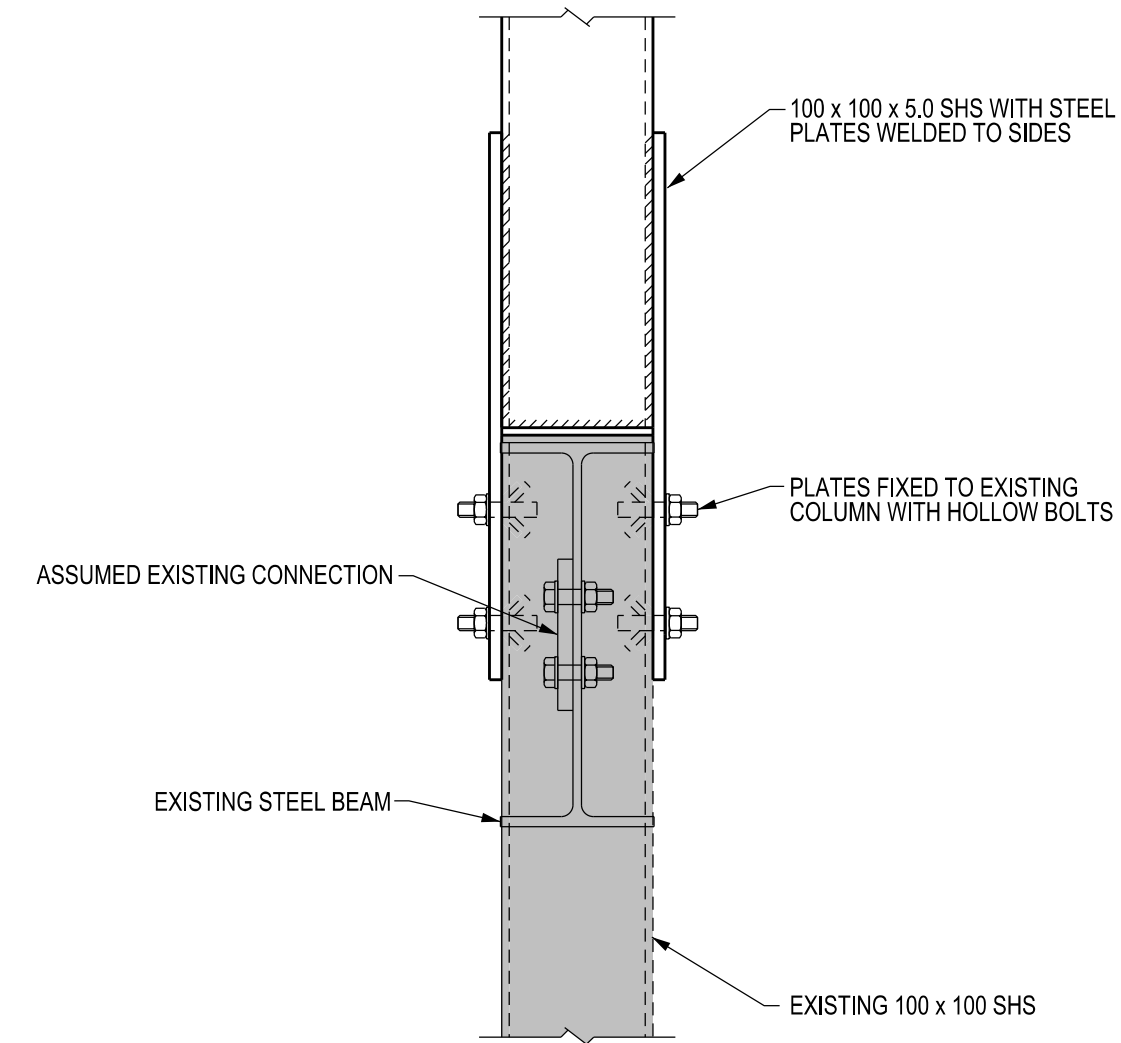

SECTION **F2**
S-100

REV.	DATE	DESCRIPTION	BY	CHECKED
T1	06.06.16	ISSUED FOR TENDER	JK	HB

TENDER

morphstructures
consulting structural & civil engineers

48 BOWLING GREEN LANE
LONDON
EC7R 0NE

T +44(0)20 7415 7032
F +44(0)20 7837 7812
W www.morphstructures.com
E info@morphstructures.com

HAVERSTOCK HILL LTD

CLIENT

94 HAVERSTOCK HILL

PROJECT

PROPOSED FIRST FLOOR
SECTIONS AND DETAILS
SHEET 1

TITLE

DATE MAY 16 DRAWN JK CHECKED CLC

SCALE 1:5 @ A1 FILENAME 2201-S-700

2201 S-700 T1

PROJECT No. DRAWING No. REVISION