

1W-06, 1W-07 & 1W-08  
(BEDROOM 5)

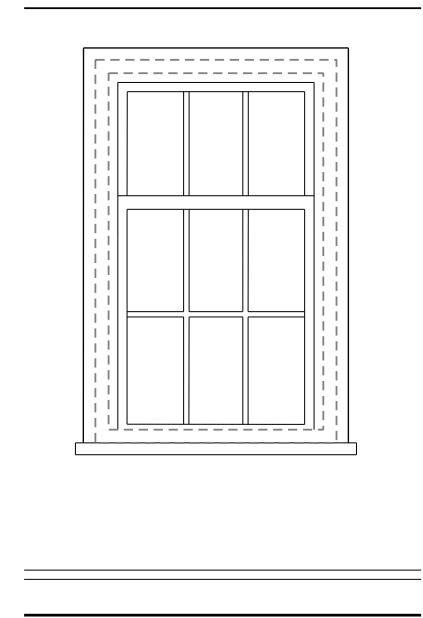
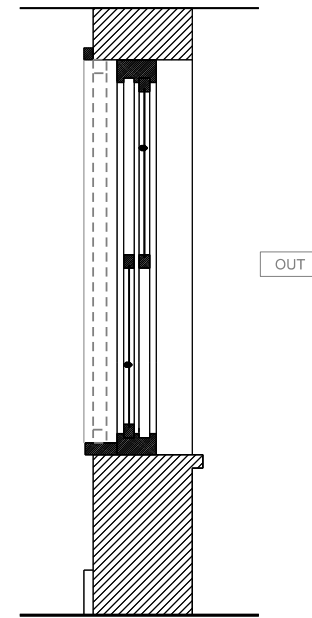

1W-06, 1W-07 & 1W-08  
(BEDROOM 5)

1 EXISTING WINDOWS  
1W-06, 1W-07 & 1W-08 (TYPE C)

2 PROPOSED WINDOWS  
1W-06, 1W-07 & 1W-08 (TYPE C)

REVISION	DATE	DESCRIPTION
-	04.03.2016	ISSUED FOR PRE-PLANNING APPLICATION ADVICE (2016)

NOTES:  
 - THIS IS A "SCHEME LEVEL DRAWING" AND IS INTENDED TO ILLUSTRATE THE GENERAL ARRANGEMENT OF THE PROJECT PROPOSALS, FOR THE PURPOSE OF PLANNING APPLICATION  
 - THIS DRAWING MUST NOT BE USED FOR CONSTRUCTION  
 - DO NOT SCALE FROM THIS DRAWING  
 - ALL DIMENSIONS MUST BE VERIFIED FROM SITE



CLIENT  
MR RON PASCALOVICI

PROJECT  
26 CHRISTCHURCH HILL  
LONDON NW3 1LG

TITLE  
EXISTING & PROPOSED SECONDARY GLAZING  
TYPE C

DWG No  
0036.P.20.204\_-

SCALE 1:20 @ A3

**ERICA JONG ARCHITECTS**  
ARCHITECTURE DESIGN MANAGEMENT

48 Falthazel Gardens London NW6 3SJ  
 T 0207 372 5768  
 E info@ericajongarchitects.com  
 www.ericajongarchitects.com

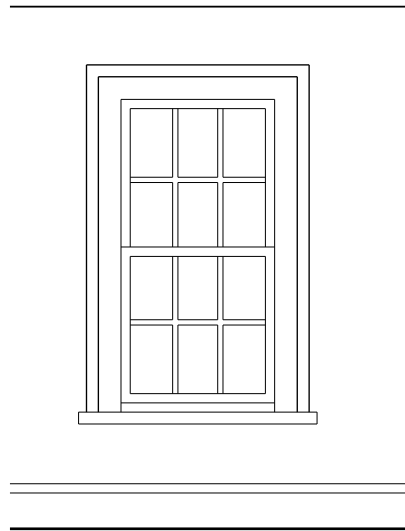
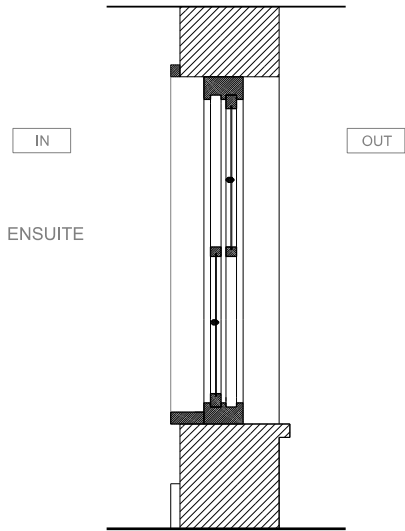
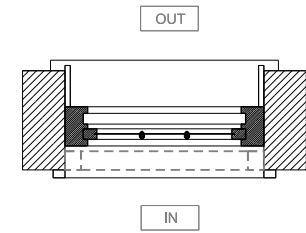
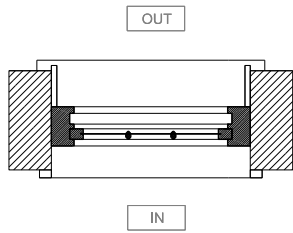

1W-09 (BEDROOM 1 ENSUITE)

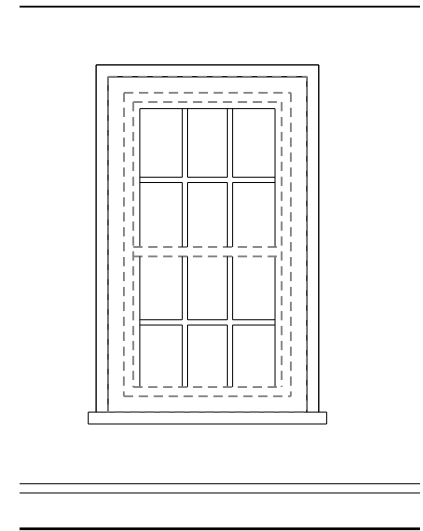
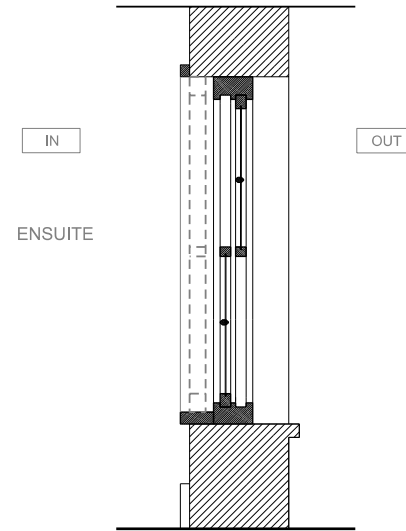

1W-09 (BEDROOM 1 ENSUITE)

1 EXISTING WINDOWS  
1W-09 (TYPE D)

2 PROPOSED WINDOWS  
1W-09 (TYPE D)

REVISION	DATE	DESCRIPTION
-	04.03.2016	ISSUED FOR PRE-PLANNING APPLICATION ADVICE (2016)

NOTES:  
 - THIS IS A "SCHEME LEVEL DRAWING" AND IS INTENDED TO ILLUSTRATE THE GENERAL ARRANGEMENT OF THE PROJECT PROPOSALS FOR THE PURPOSE OF PLANNING APPLICATION  
 - THIS DRAWING MUST NOT BE USED FOR CONSTRUCTION  
 - DO NOT SCALE FROM THIS DRAWING  
 - ALL DIMENSIONS MUST BE VERIFIED FROM SITE



CLIENT  
MR RON PASCALOVICI

PROJECT  
26 CHRISTCHURCH HILL  
LONDON NW3 1LG

TITLE  
EXISTING & PROPOSED SECONDARY GLAZING  
TYPE D

DWG No  
0036.P.20.205\_-

SCALE 1:20 @ A3

ERICA JONG ARCHITECTS  
ARCHITECTURE DESIGN MANAGEMENT

48 Fairhazel Gardens London NW6 3SJ  
 T 0207 372 5768  
 E Info@ericajongarchitects.com  
 www.ericajongarchitects.com

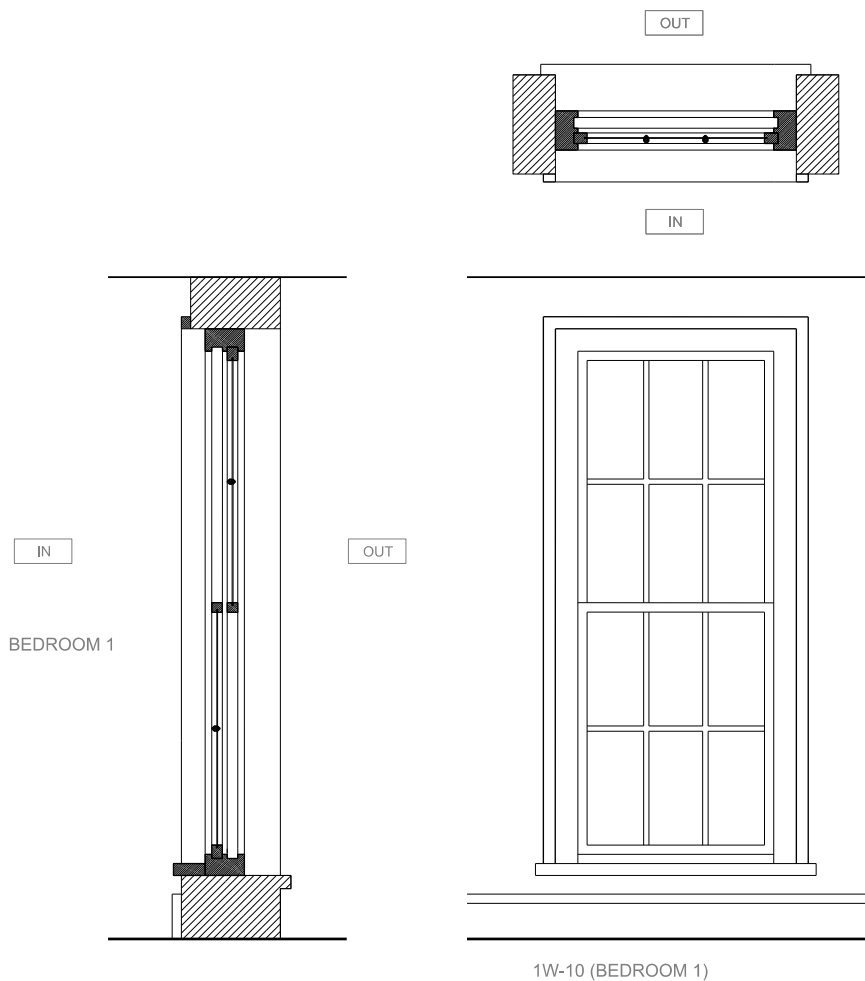

1 EXISTING WINDOWS  
1W-10 (TYPE E)

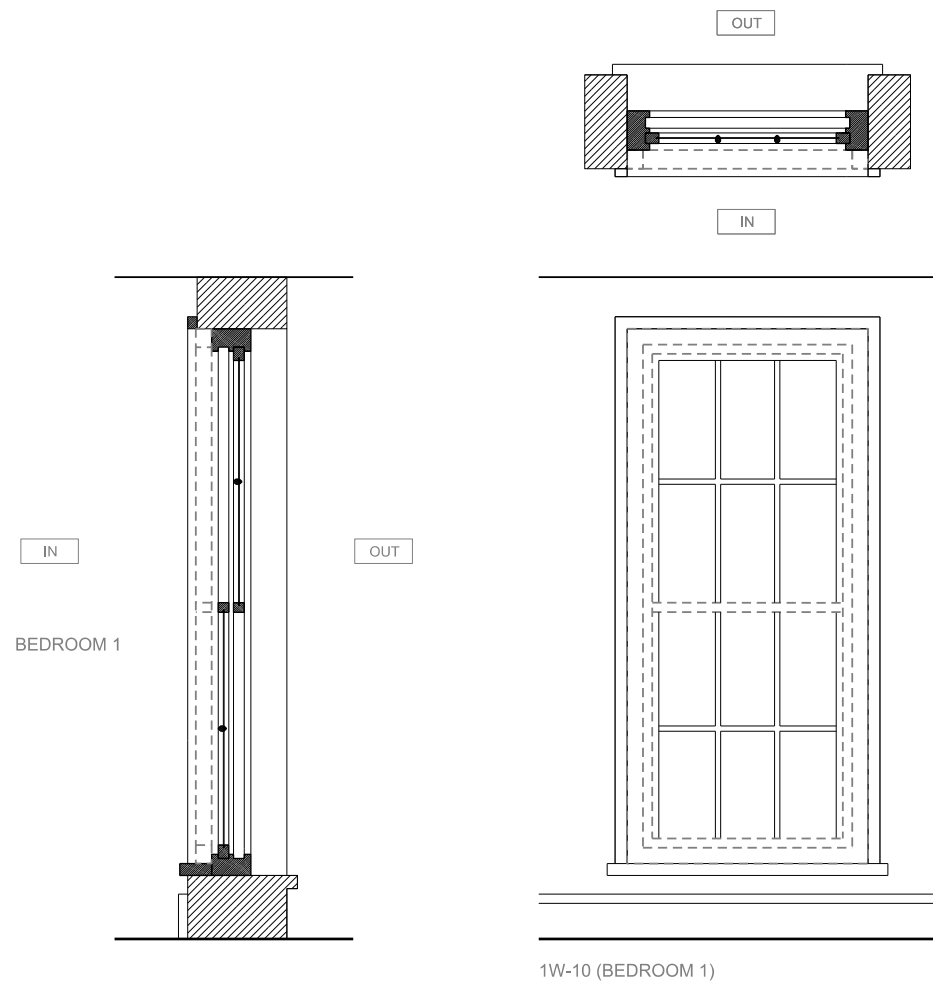

2 PROPOSED WINDOWS  
1W-10 (TYPE E)

REVISION	DATE	DESCRIPTION
-	04.03.2016	ISSUED FOR PRE-PLANNING APPLICATION ADVICE (2016)

NOTES:  
 - THIS IS A 'SCHEME LEVEL DRAWING' AND IS INTENDED TO ILLUSTRATE THE GENERAL ARRANGEMENT OF THE PROJECT PROPOSALS FOR THE PURPOSE OF PLANNING APPLICATION  
 - THIS DRAWING MUST NOT BE USED FOR CONSTRUCTION  
 - DO NOT SCALE FROM THIS DRAWING  
 - ALL DIMENSIONS MUST BE VERIFIED FROM SITE



CLIENT  
MR RON PASCALOVICI

PROJECT  
26 CHRISTCHURCH HILL  
LONDON NW3 1LG

TITLE  
EXISTING & PROPOSED SECONDARY GLAZING  
TYPE D

DWG No  
0036.P.20.206\_-

**ERICA JONG ARCHITECTS**  
 ARCHITECTURE DESIGN MANAGEMENT

48 Falhazel Gardens London NW6 3SJ  
 T 0207 372 5768  
 E info@ericajongarchitects.com  
 www.ericajongarchitects.com

SCALE 1:20 @ A3

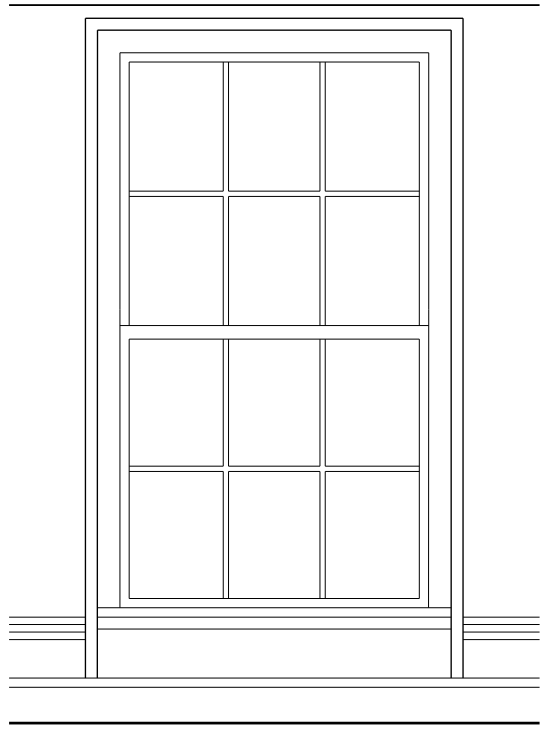
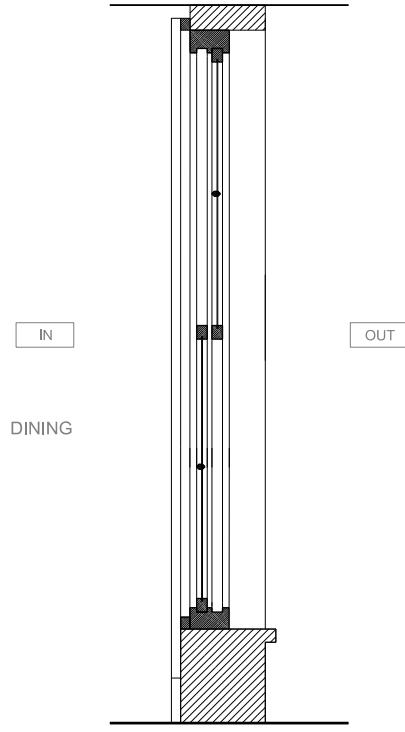
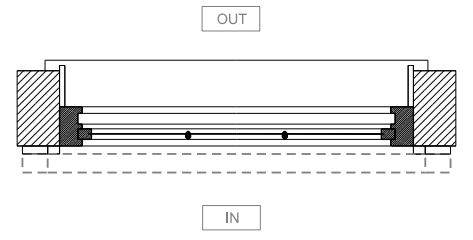
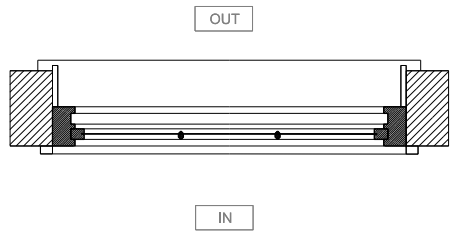

GW-01 (DINING)  
GW-11 (RECEPTION 1) - SIM

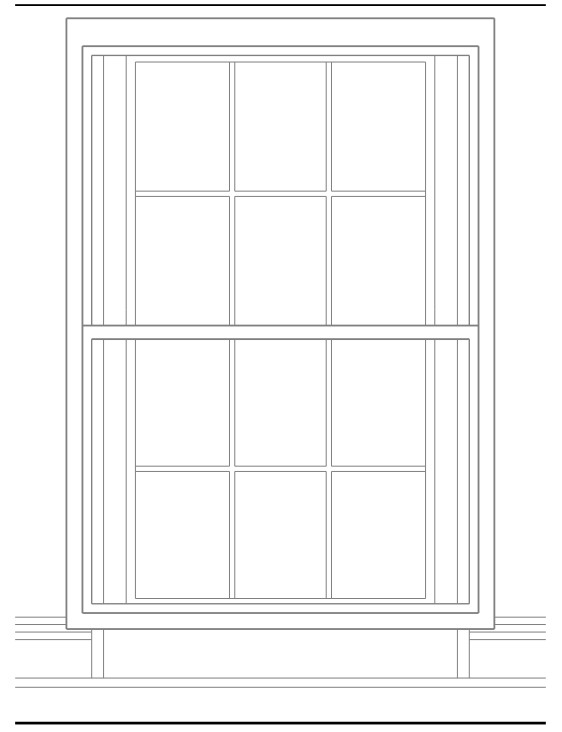
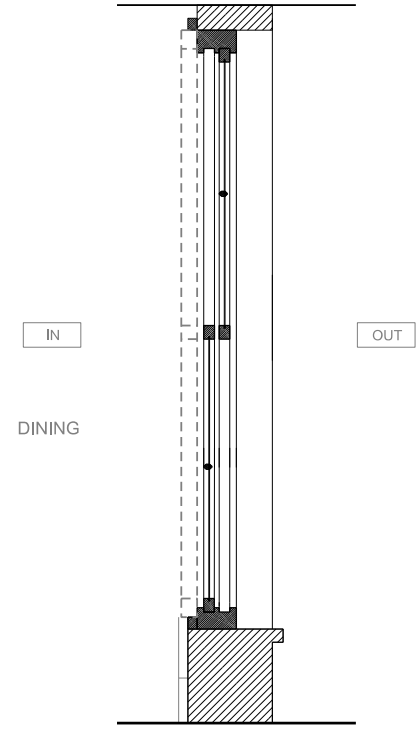

GW-01 (DINING)  
GW-11 (RECEPTION 1) - SIM

1 EXISTING WINDOWS  
GW-01, GW-11 (TYPE F)

2 PROPOSED WINDOWS  
GW-01, GW-11 (TYPE F)

REVISION	DATE	DESCRIPTION
-	04.03.2016	ISSUED FOR PRE-PLANNING APPLICATION ADVICE (2016)

NOTES:  
 - THIS IS A "SCHEME LEVEL DRAWING" AND IS INTENDED TO ILLUSTRATE THE GENERAL ARRANGEMENT OF THE PROJECT PROPOSALS FOR THE PURPOSE OF PLANNING APPLICATION  
 - THIS DRAWING MUST NOT BE USED FOR CONSTRUCTION  
 - DO NOT SCALE FROM THIS DRAWING  
 - ALL DIMENSIONS MUST BE VERIFIED FROM SITE



CLIENT  
MR RON PASCALOVICI

PROJECT  
26 CHRISTCHURCH HILL  
LONDON NW3 1LG

TITLE  
EXISTING & PROPOSED SECONDARY GLAZING  
TYPE F

DWG No  
0036.P.20.207\_-

SCALE 1:20 @ A3

**ERICA JONG ARCHITECTS**  
 ARCHITECTURE DESIGN MANAGEMENT

48 Fairhazel Gardens London NW6 3SJ  
 T 0207 372 5768  
 E Info@ericajongarchitects.com  
 www.ericajongarchitects.com

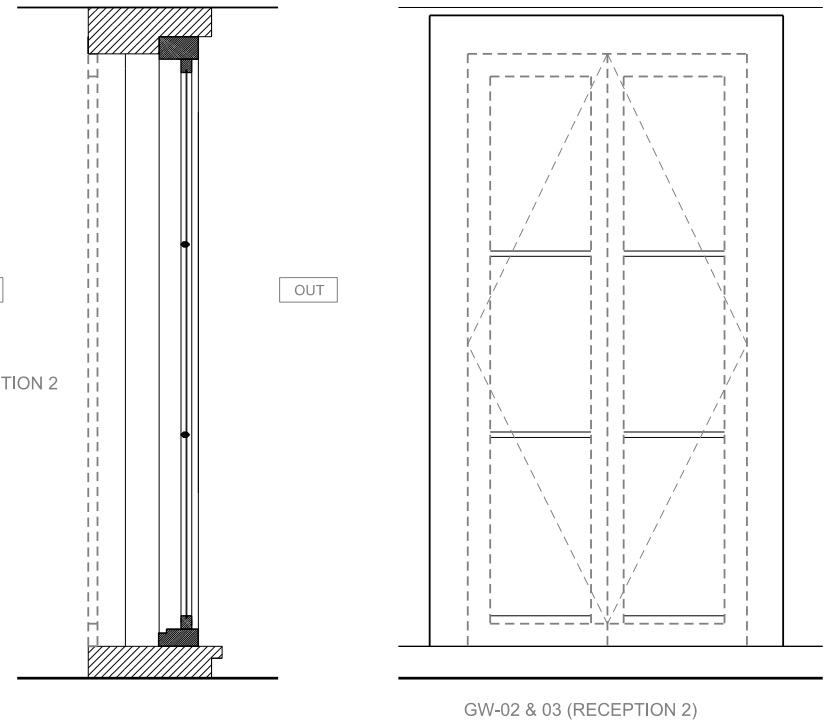
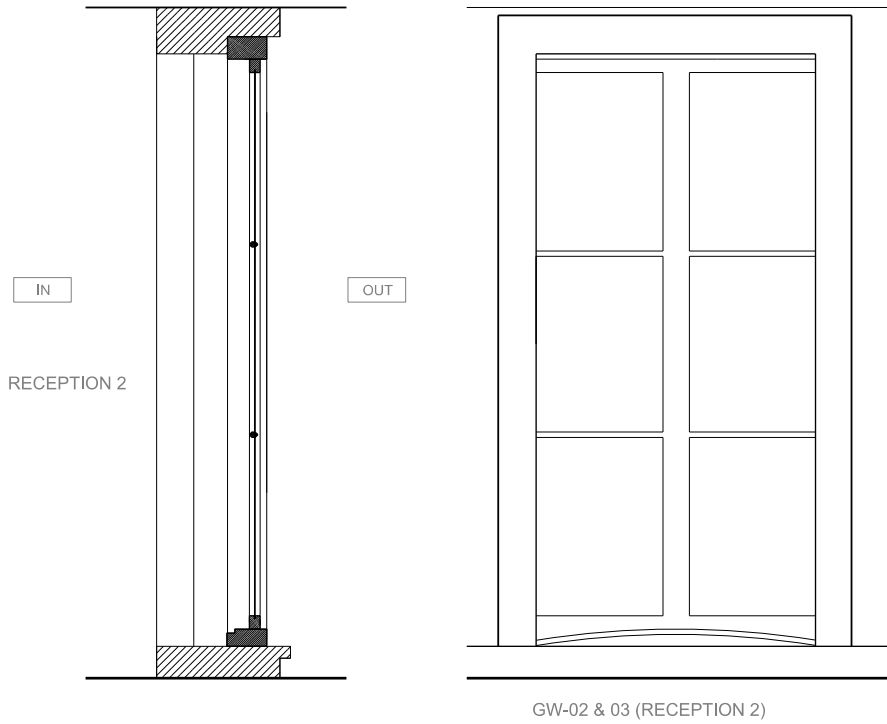
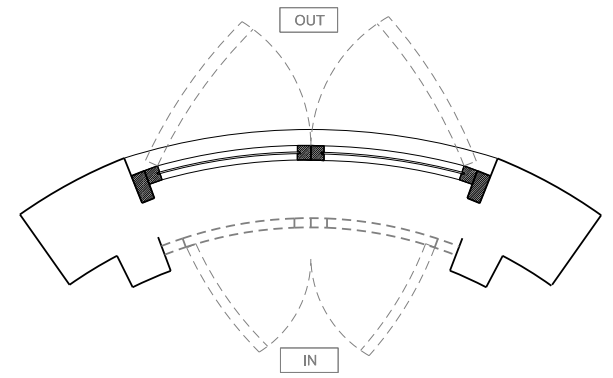
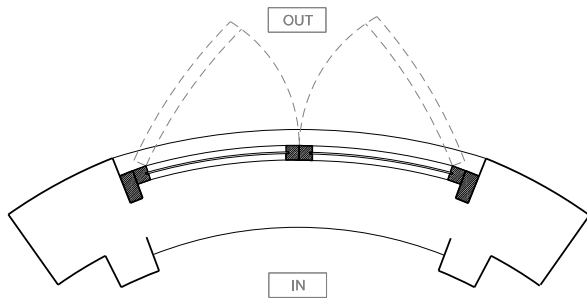

1 EXISTING GLAZED DOORS  
GW-02 & 03 (TYPE G)

2 PROPOSED GLAZED DOORS  
GW-02 & 03 (TYPE G)

REVISION

04.03.2016 ISSUED FOR PRE-PLANNING APPLICATION ADVICE (2016)

NOTES:

- THIS IS A "SCHEME LEVEL DRAWING" AND IS INTENDED TO ILLUSTRATE THE GENERAL ARRANGEMENT OF THE PROJECT PROPOSALS FOR THE PURPOSE OF PLANNING APPLICATION
- THIS DRAWING MUST NOT BE USED FOR CONSTRUCTION
- DO NOT SCALE FROM THIS DRAWING
- ALL DIMENSIONS MUST BE VERIFIED FROM SITE



CLIENT

MR RON PASCALOVICI

PROJECT

26 CHRISTCHURCH HILL  
LONDON NW3 1LG

TITLE

EXISTING & PROPOSED SECONDARY GLAZING  
TYPE G

DWG No

0036.P.20.208\_-

SCALE 1:20 @ A3

ERICA JONG ARCHITECTS  
ARCHITECTURE DESIGN MANAGEMENT

48 Falhazel Gardens London NW6 3SJ  
T 0207 372 5768  
E info@ericajongarchitects.com  
www.ericajongarchitects.com

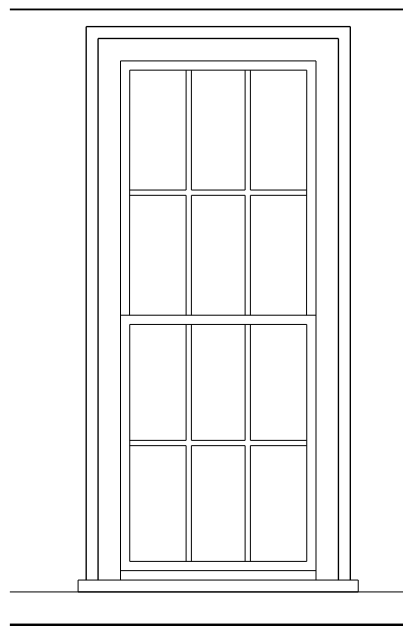
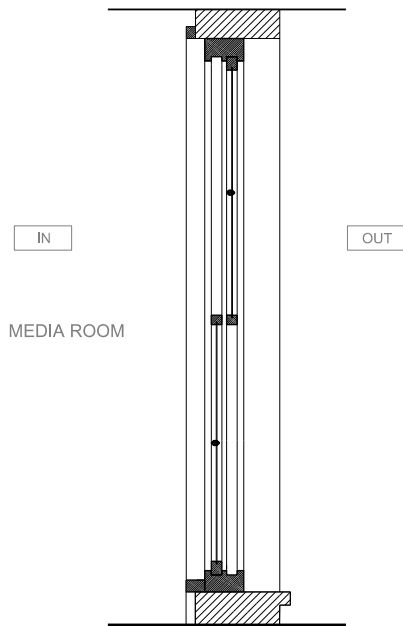
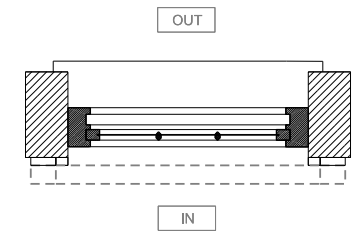
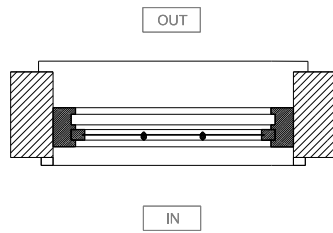

GW-04 & 06 (MEDIA ROOM)

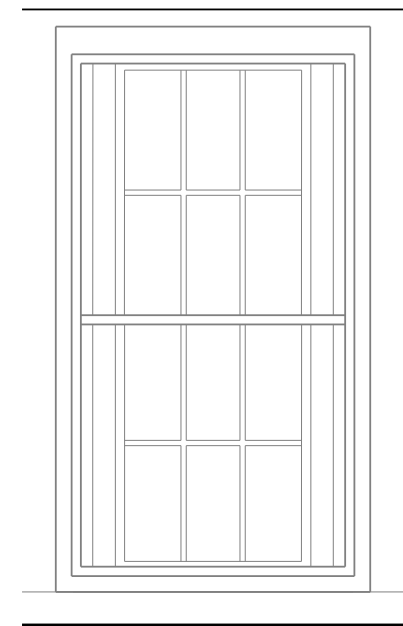
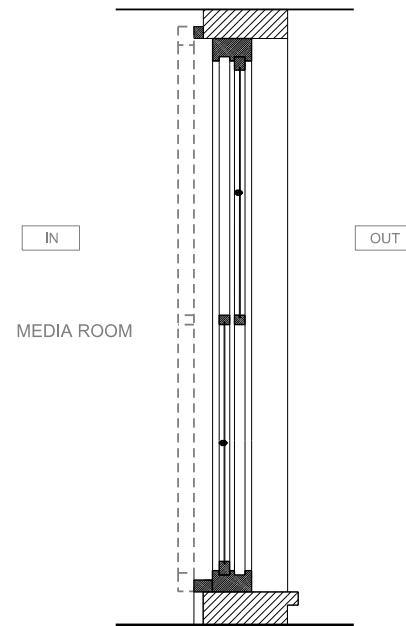

GW-04 & 06 (MEDIA ROOM)

1 EXISTING WINDOWS  
GW-04 & 06 (TYPE H)

2 PROPOSED WINDOWS  
GW-04 & 06 (TYPE H)

REVISION

04.03.2016 ISSUED FOR PRE-PLANNING APPLICATION ADVICE (2016)

NOTES:  
 - THIS IS A 'SCHEME LEVEL DRAWING' AND IS INTENDED TO ILLUSTRATE THE GENERAL ARRANGEMENT OF THE PROJECT PROPOSALS FOR THE PURPOSE OF PLANNING APPLICATION  
 - THIS DRAWING MUST NOT BE USED FOR CONSTRUCTION  
 - DO NOT SCALE FROM THIS DRAWING  
 - ALL DIMENSIONS MUST BE VERIFIED FROM SITE



CLIENT MR RON PASCALOVICI

PROJECT 26 CHRISTCHURCH HILL  
LONDON NW3 1LG

TITLE EXISTING & PROPOSED SECONDARY GLAZING  
TYPE H

DWG No 0036.P.20.209\_-

SCALE 1:20 @ A3

ERICA JONG ARCHITECTS  
ARCHITECTURE DESIGN MANAGEMENT

48 Falthazel Gardens London NW6 3SJ  
 T 0207 372 5768  
 E info@ericajongarchitects.com  
 www.ericajongarchitects.com

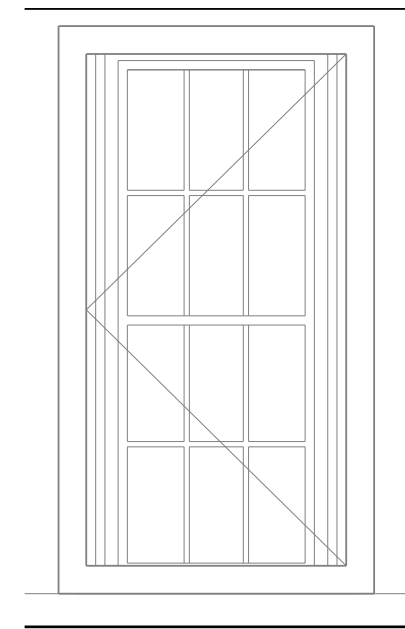
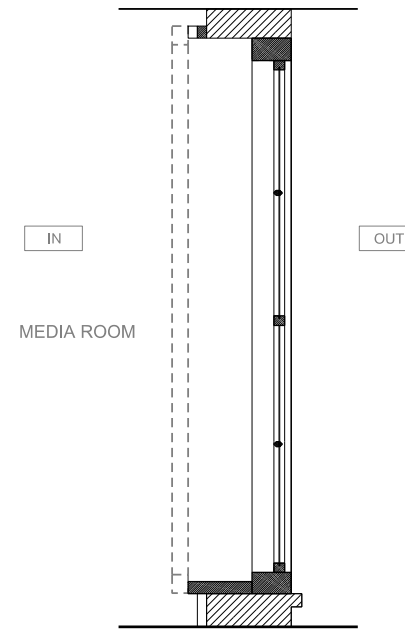
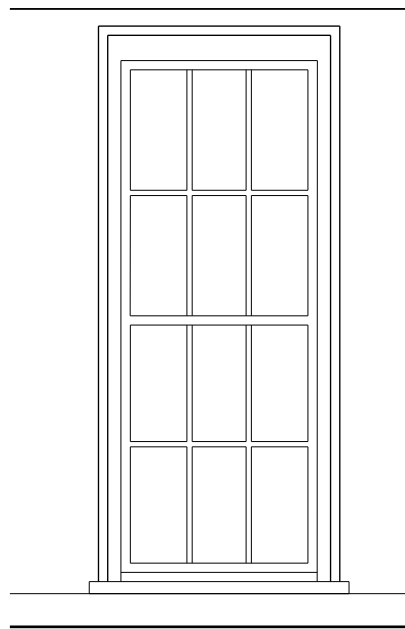
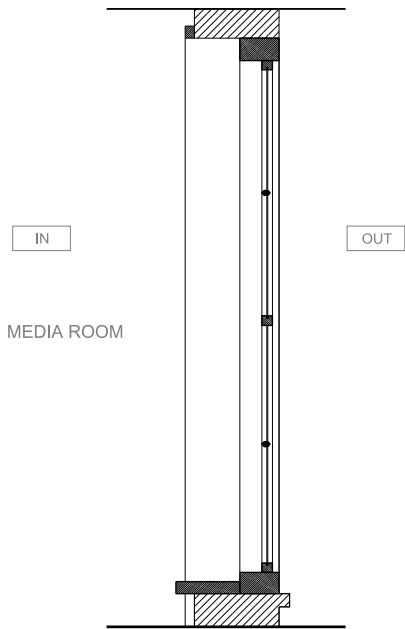
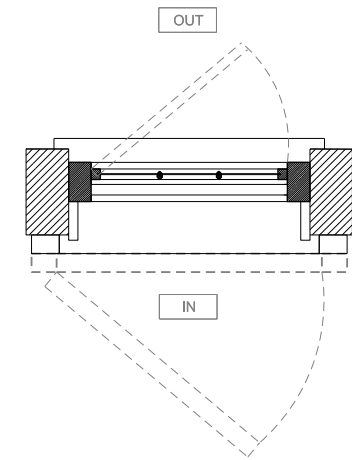
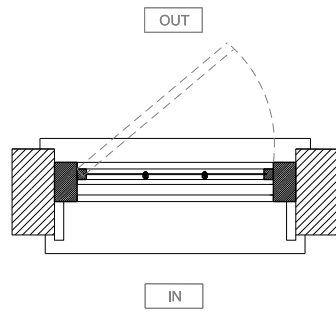

1 EXISTING GLAZED DOOR  
GW-05 (TYPE I)

2 PROPOSED GLAZED DOOR  
GW-05 (TYPE I)

REVISION	DATE	DESCRIPTION
-	04.03.2016	ISSUED FOR PRE-PLANNING APPLICATION ADVICE (2016)

NOTES:  
 - THIS IS A "SCHEME LEVEL DRAWING" AND IS INTENDED TO ILLUSTRATE THE GENERAL ARRANGEMENT OF THE PROJECT PROPOSALS FOR THE PURPOSE OF PLANNING APPLICATION  
 - THIS DRAWING MUST NOT BE USED FOR CONSTRUCTION  
 - DO NOT SCALE FROM THIS DRAWING  
 - ALL DIMENSIONS MUST BE VERIFIED FROM SITE



CLIENT  
MR RON PASCALOVICI

PROJECT  
26 CHRISTCHURCH HILL  
LONDON NW3 1LG

TITLE  
EXISTING & PROPOSED SECONDARY GLAZING  
TYPE I

DWG No  
0036.P.20.210\_-

SCALE 1:20 @ A3

**ERICA JONG ARCHITECTS**  
ARCHITECTURE DESIGN MANAGEMENT

48 Fairhazel Gardens London NW6 3SJ  
 T [0]207 372 5768  
 E info@ericajongarchitects.com  
 www.ericajongarchitects.com

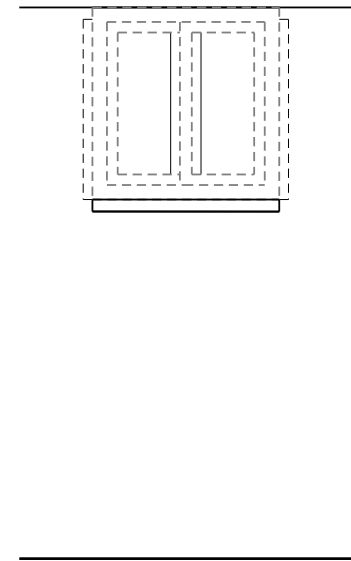
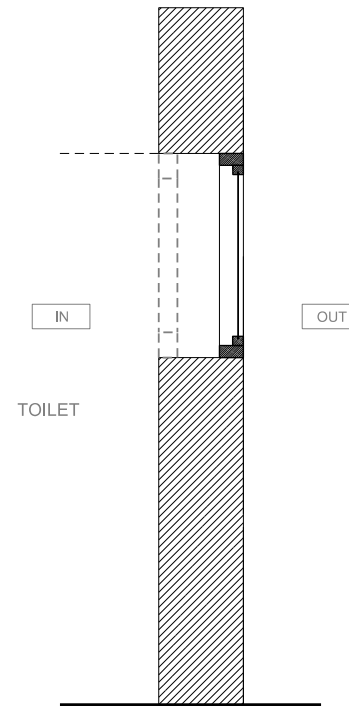
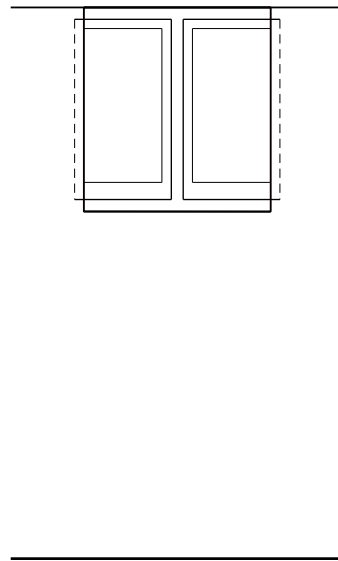
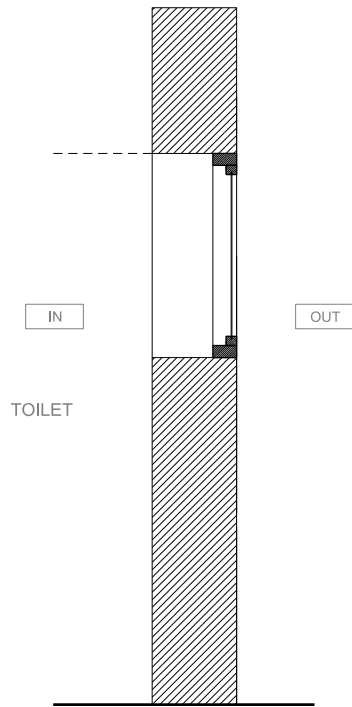
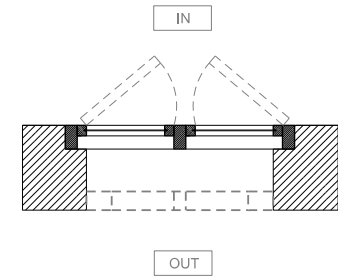
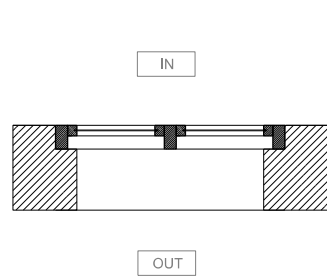

GW-07

GW-07

1 EXISTING TOILET WINDOW  
GW-07 (TYPE J)

2 PROPOSED TOILET WINDOW  
GW-07 (TYPE J)

REVISION

04.03.2016 ISSUED FOR PRE-PLANNING APPLICATION ADVICE (2016)

NOTES:  
- THIS IS A "SCHEME LEVEL DRAWING" AND IS INTENDED TO ILLUSTRATE THE GENERAL ARRANGEMENT OF THE PROJECT PROPOSALS FOR THE PURPOSE OF PLANNING APPLICATION  
- THIS DRAWING MUST NOT BE USED FOR CONSTRUCTION  
- DO NOT SCALE FROM THIS DRAWING  
- ALL DIMENSIONS MUST BE VERIFIED FROM SITE



CLIENT MR RON PASCALOVICI

PROJECT 26 CHRISTCHURCH HILL  
LONDON NW3 1LG

TITLE EXISTING & PROPOSED SECONDARY GLAZING  
TYPE M

DWG No 0036.P.20.211\_- | SCALE 1:20 @ A3

ERICA JONG ARCHITECTS  
ARCHITECTURE DESIGN MANAGEMENT

48 Fairhazel Gardens London NW6 3SJ  
T 0207 372 5768  
E info@ericajongarchitects.com  
www.ericajongarchitects.com



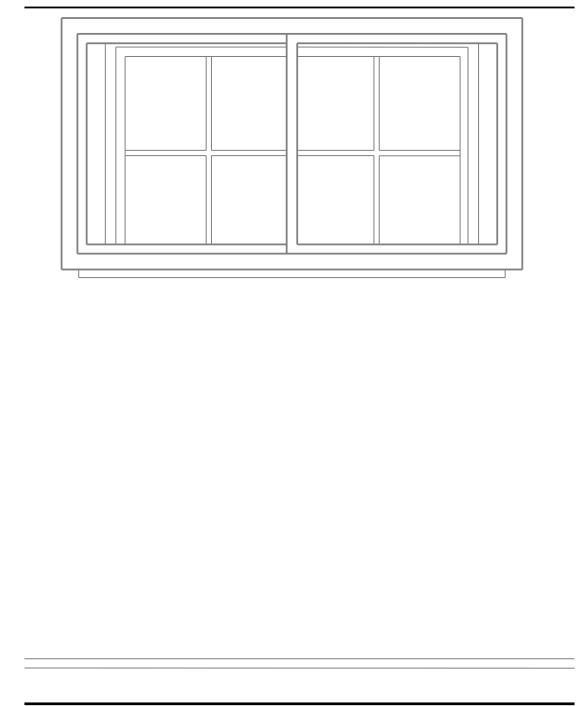
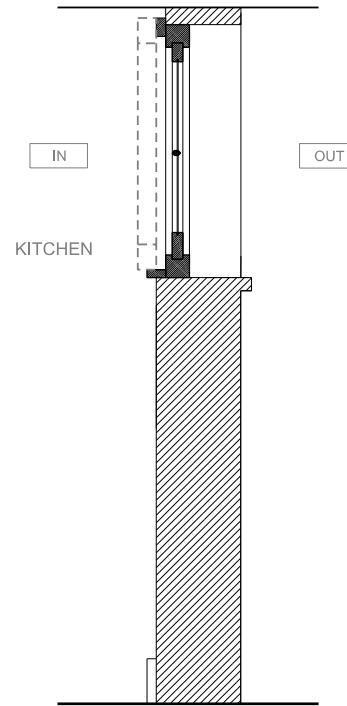
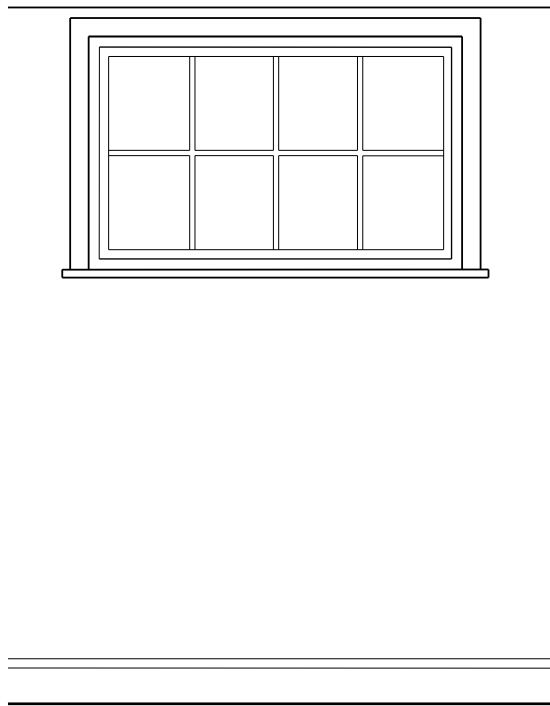
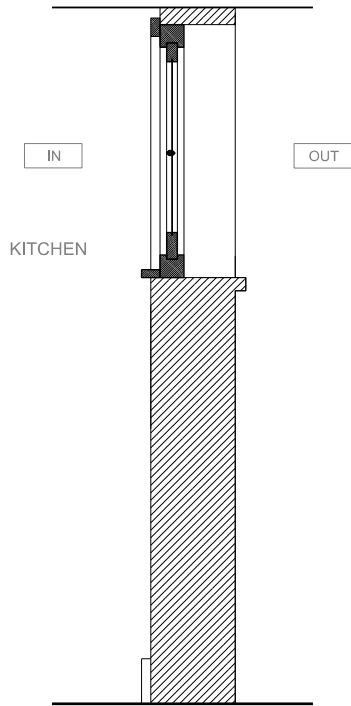
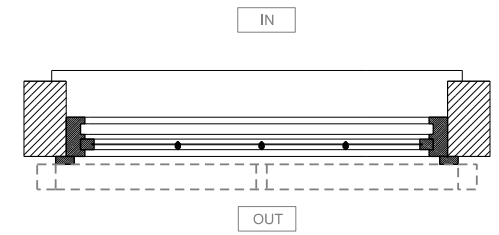
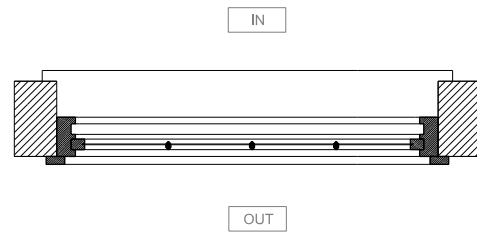

1 EXISTING WINDOW TO KITCHEN  
GW-08 (TYPE K)

2 PROPOSED WINDOW TO KITCHEN  
GW-08 (TYPE K)

REVISION	DATE	DESCRIPTION
-	04.03.2016	ISSUED FOR PRE-PLANNING APPLICATION ADVICE (2016)

NOTES:  
 - THIS IS A "SCHEME LEVEL DRAWING" AND IS INTENDED TO ILLUSTRATE THE GENERAL ARRANGEMENT OF THE PROJECT PROPOSALS FOR THE PURPOSE OF PLANNING APPLICATION  
 - THIS DRAWING MUST NOT BE USED FOR CONSTRUCTION  
 - DO NOT SCALE FROM THIS DRAWING  
 - ALL DIMENSIONS MUST BE VERIFIED FROM SITE



CLIENT  
MR RON PASCALOVICI

PROJECT  
26 CHRISTCHURCH HILL  
LONDON NW3 1LG

TITLE  
EXISTING & PROPOSED SECONDARY GLAZING  
TYPE K

DWG No  
0036.P.20.212\_- | SCALE 1:20 @ A3

**ERICA JONG ARCHITECTS**  
ARCHITECTURE DESIGN MANAGEMENT

48 Falhazel Gardens London NW6 3SJ  
 T 0207 372 5768  
 E info@ericajongarchitects.com  
 www.ericajongarchitects.com

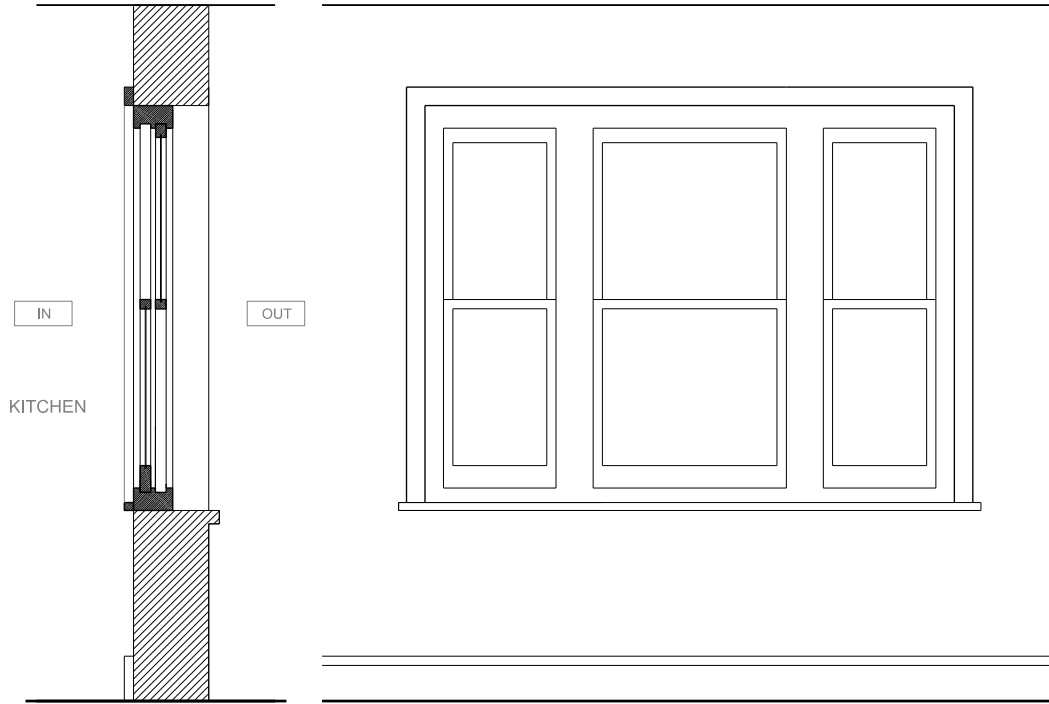
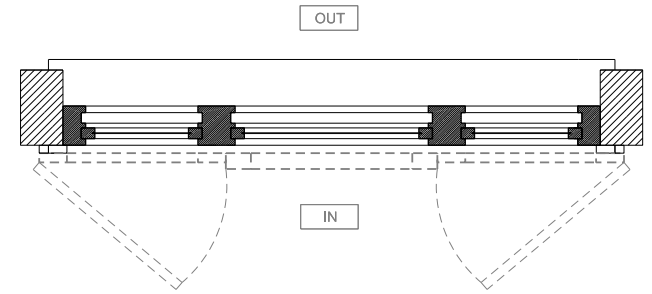
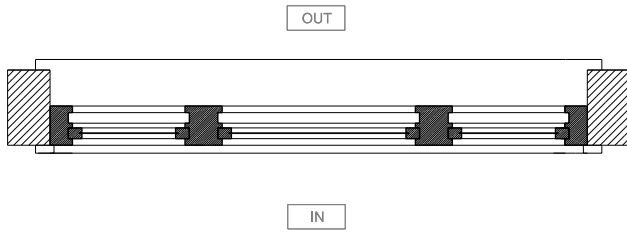

GW-09 (KITCHEN)

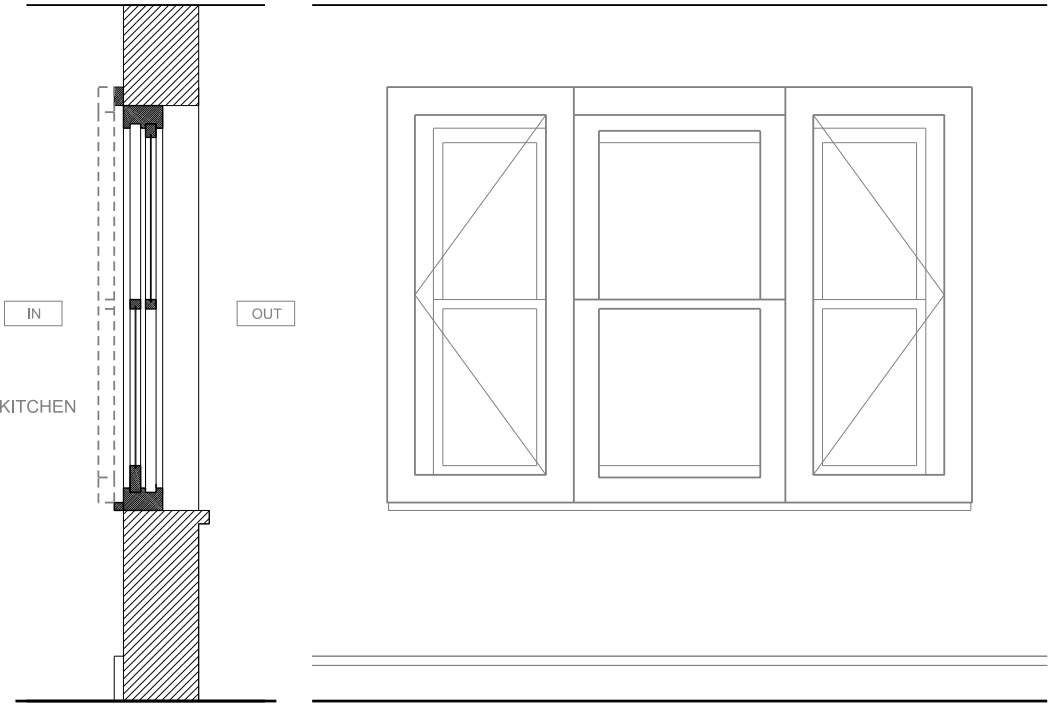

GW-09 (KITCHEN)

1 EXISITNG WINDOW  
GW-09 (TYPE L)

2 PROPOSED WINDOW  
GW-08 (TYPE L)

REVISION

04.03.2016 ISSUED FOR PRE-PLANNING APPLICATION ADVICE (2016)

NOTES:  
 - THIS IS A "SCHEME LEVEL DRAWING" AND IS INTENDED TO ILLUSTRATE THE GENERAL ARRANGEMENT OF THE PROJECT PROPOSALS FOR THE PURPOSE OF PLANNING APPLICATION  
 - THIS DRAWING MUST NOT BE USED FOR CONSTRUCTION  
 - DO NOT SCALE FROM THIS DRAWING  
 - ALL DIMENSIONS MUST BE VERIFIED FROM SITE



CLIENT MR RON PASCALOVICI

PROJECT 26 CHRISTCHURCH HILL  
LONDON NW3 1LG

TITLE EXISTING & PROPOSED SECONDARY GLAZING  
TYPE L

DWG No 0036.P.20.213\_-

SCALE 1:20 @ A3

ERICA JONG ARCHITECTS  
ARCHITECTURE DESIGN MANAGEMENT

48 Falrhazel Gardens London NW6 3SJ  
 T 01207 372 5768  
 E info@ericajongarchitects.com  
 www.ericajongarchitects.com

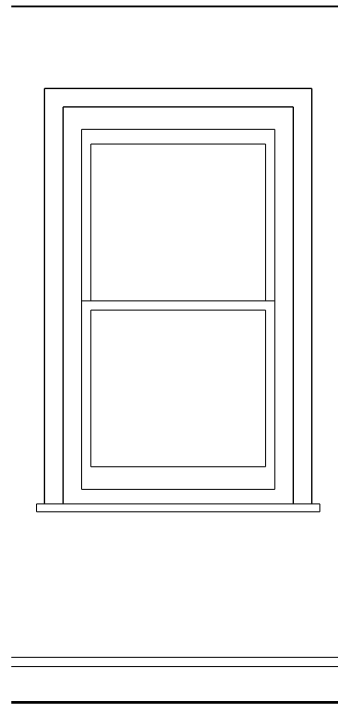
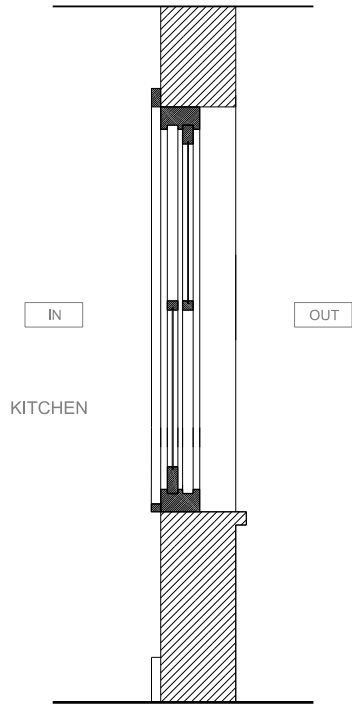
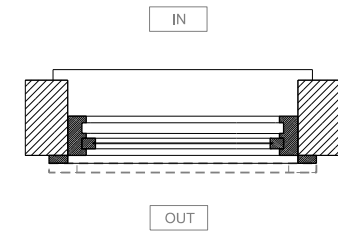
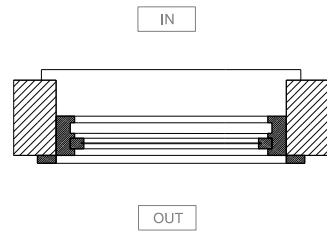

GW-10

1 EXISTING KITCHEN WINDOW  
GW-10 (TYPE M)

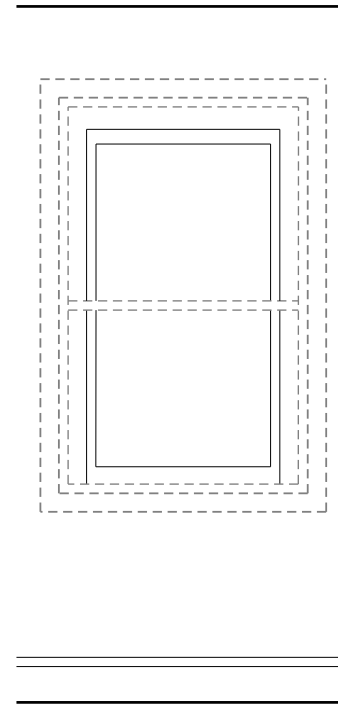
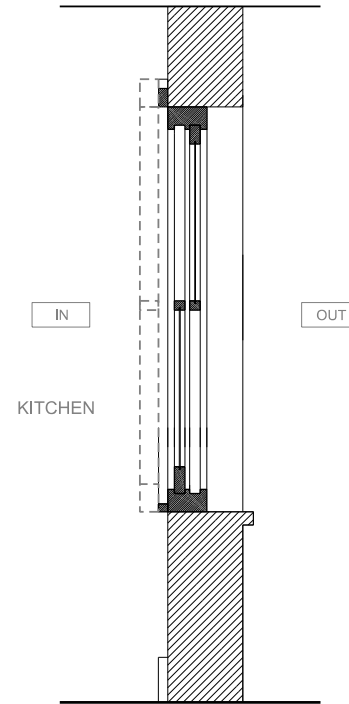

GW-10

2 PROPOSED KITCHEN WINDOW  
GW-10 (TYPE M)

REVISION

04.03.2016 ISSUED FOR PRE-PLANNING APPLICATION ADVICE (2016)

NOTES:  
- THIS IS A "SCHEME LEVEL DRAWING" AND IS INTENDED TO ILLUSTRATE THE GENERAL ARRANGEMENT OF THE PROJECT PROPOSALS FOR THE PURPOSE OF PLANNING APPLICATION  
- THIS DRAWING MUST NOT BE USED FOR CONSTRUCTION  
- DO NOT SCALE FROM THIS DRAWING  
- ALL DIMENSIONS MUST BE VERIFIED FROM SITE



CLIENT MR RON PASCALOVICI

PROJECT 26 CHRISTCHURCH HILL  
LONDON NW3 1LG

TITLE EXISTING & PROPOSED SECONDARY GLAZING  
TYPE M

DWG No 0036.P.20.214\_-

SCALE 1:20 @ A3

ERICA JONG ARCHITECTS  
ARCHITECTURE DESIGN MANAGEMENT

48 Fairhazel Gardens London NW6 3SJ  
T 0207 372 5768  
E info@ericajongarchitects.com  
www.ericajongarchitects.com