

ENLARGED PART ELEVATION ON WEST FACE
SCALE 1:20

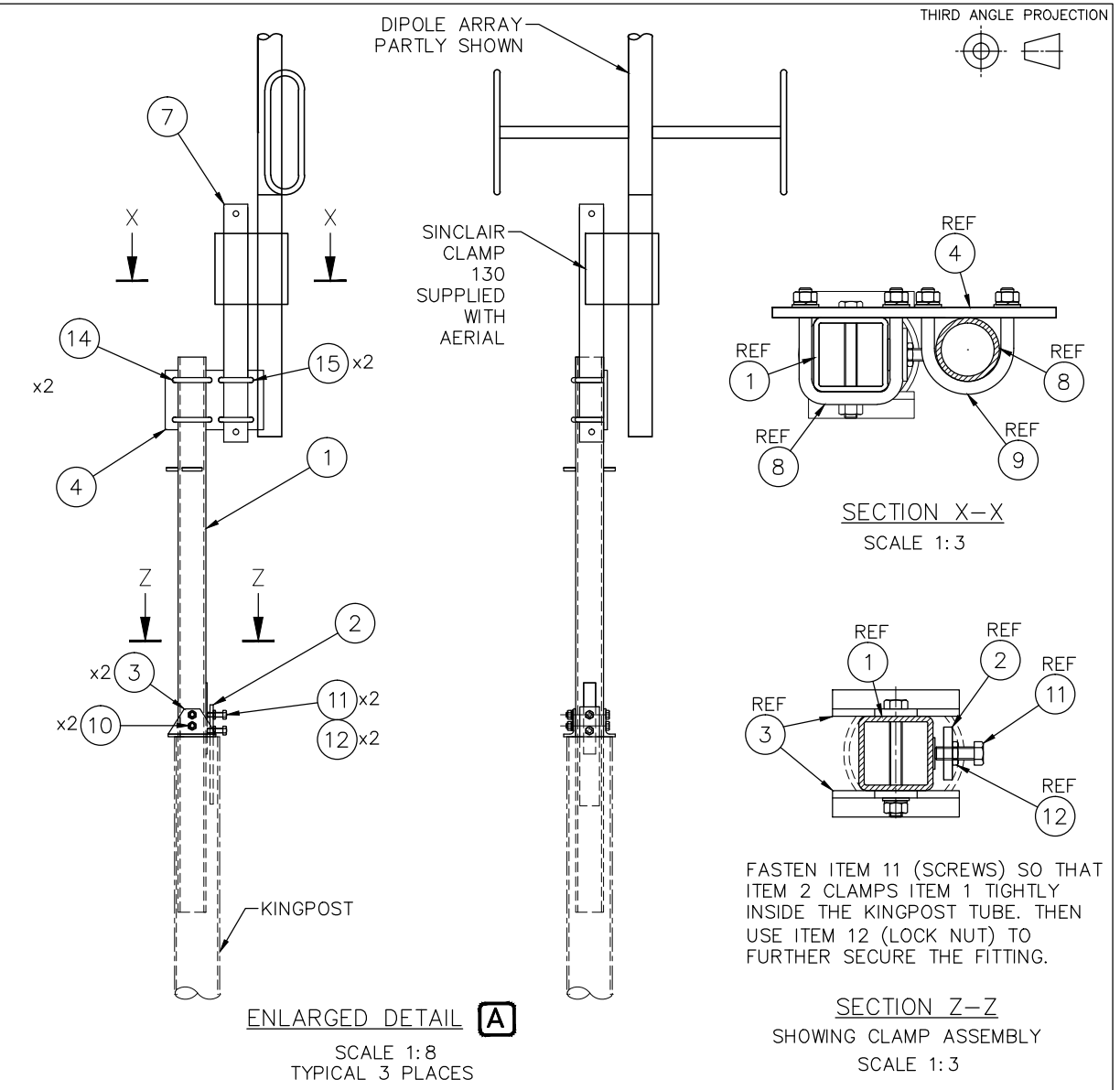

SCHEDULE				
ITEM	DESCRIPTION	WT/ITEM (kg)	QTY	WL DRG No.
1	S.H.S 70x70x5 1400 LG FABRICATED.	12.0	3	SHEET 3
2	PLATE 250x50x8 FABRICATED.	0.8	3	SHEET 3
3	ANGLE 70x70x6 120 LG FABRICATED.	0.6	6	SHEET 3
4	CROSSOVER PLATE 245x150x10 FABRICATED.	2.9	1	SHEET 3
5	STANDARD CROSSOVER PLATE (Ø114 X Ø114)	4.7	2	WL221691/WL4004005
6	C.H.S Ø114x5 3500 LG WITH T BARS	48.7	1	WL4004527 SH 5
7	C.H.S Ø60x5 600 LG WITH T BARS	4.1	3	WL4004527 SH 2
8	SQ U-BOLT SQB/M12/70 PITCH = 86	0.4	6	WL4004008
9	U-BOLT UB/M12/60 PITCH = 75	0.3	6	WL4004005
10	M12 HEX HD BOLT 100 LG		6	SEE NOTE 2
11	M12 HEX HD SCREW 40 LONG		6	
12	M12 LOCK NUT		6	

- NOTES
1. ALL ITEMS BUNDLING AND DELIVERY MUST CONFORM TO SPECIFICATION RC 8832
 2. ITEM 10 TO BE SUPPLIED WITH HEX NUT, S/C SPRING WASHER & PLAIN WASHER.
 3. TOTAL WEIGHT (EXCLUDING AERIALS) = 117.7kg.

DIMENSIONS IN mm UNLESS OTHERWISE STATED © British Telecommunications plc 2016 DO NOT SCALE ORIGINAL SCALE AS SHOWN

A1
A2
DRN S.A.D
CKD BCJ
CERTIFICATION
DESIGNER
B. JOHNSON
CLIENT
A. MILLER
DATE 27 09 16

ANY MODIFICATION TO THE DRAWING OR THE USE OF ALTERNATIVE ITEMS TO THOSE SPECIFIED MUST BE AGREED WITH THE DESIGNER.

MATERIAL
SEE BT SPEC RC8832

FINISH
SEE BT SPEC RC8832

A
LONDON TELECOM TOWER
1 x 0.8m DISH AND
3 x 2.9m DIPOLE ARRAYS
ON LEVEL T37 AT 167m ATD
MOUNT ASSEMBLY DETAILS
REFERENCES
BT SPEC RC8832
SEE SCHEDULE
S/A 2016/0592-0585
DISH SIZE 2x0.6m
AMENDMENT ISSUE BT TSO UK RSDO WL 4005106 SHT 02 OF 03

WL4005106sh01.DWG