

| METHOD STATEMENT |
|---|
| <p>Contract SP4101</p> <p>Steel Sheet Pile installation – Greenwood Place</p> <p>Keltbray Sheet Piling</p> |

| | | | |
|----------------------|--------------------------------|--------------|---------|
| Company | Keltbray – Sheet Piling | | |
| Method statement No. | KSP-SP4101-MS-001 | Revision No. | 00 |
| Title | Steel Sheet Pile installation | | |
| Start Date of Works | 19 th December 2016 | Duration | 5 weeks |

| Revision History | | | | |
|------------------|--------------|------------|--------|------------------------------|
| Document No. | Revision No. | Issue Date | Author | Description of Modifications |
| | | | | |

| This Revision | | | | |
|---------------|--------------|-----------|-------------------|------------|
| | Print Name | Signature | Position | Issued to: |
| | Tim Davidson | | Contracts Manager | Kier |

| Status of This Revision |
|-------------------------|
|-------------------------|

| Overall Approval Status | Yes | No | Date |
|---|-----|----|------|
| Cat A Accepted for implementation. Work may proceed as planned. | | | |
| Cat B Not accepted for implementation. Resubmission required. | | | |
| Date Returned to Contractor | | | |

| | Print Name | Signature | Date |
|-----------------------------|------------|-----------|------|
| Sign off by Project Manager | | | |
| | | | |

Table of Contents

1. Scope of Works
2. Enabling Works
3. Resources
4. Training
5. Method of Works
6. Logistics
7. Hazards & Risks
8. Control Measures
9. Emergency Arrangements
10. Contractor Monitoring & Compliance

Appendix A - Method Statement briefing sheet

Appendix B - Typical Plant Layout for Tosa works.

Appendix C - Plant Details

Appendix D - Site Constraints.

Appendix E - Basement Plan and sections.

Appendix F – Outline Tender Program.

Health and Safety Factors

| Piling Works | Key Factors |
|---------------------|---|
| Design | <ul style="list-style-type: none"> ▪ Knowledge of ground conditions ▪ Structural knowledge of any existing foundations ▪ Knowledge of loads and factors applied to new steel sheet piles |
| Planning | <ul style="list-style-type: none"> ▪ Site knowledge ▪ Health and Safety risk assessment ▪ Equipment and methodology and sequence of works |
| Execution | <ul style="list-style-type: none"> ▪ Workforce Supervision ▪ Control of method statements implementation ▪ Communication of unplanned discoveries ▪ Safety information and training selection |

1. Scope of Works

This method statement covers the installation of a permanent sheet pile cofferdam to provide a temporary earth retaining and a permanent basement structure.

Sheet pile layout see Appendix E

Pre – Auger (soil loosening) will be carried out by an EM400 or similar

The sheet piles will be installed by use of the Tosa WP150 silent pile press system complete with Water Jetting.

The sheet piles will be handled by 50T capacity crawler crane.

2. Enabling Works

- Probe and remove obstructions (by others) Subsurface Infrastructures
- The probing for the sheet piling and the subsequent installation of the sheet piles is unlikely to have any effect on the sub surface infrastructures because they are in Greenwood Place. See Appendix D for plan of the works although exact details of sewer are unknown. Proposed basement structure over 3m away from Thames Water sewer.
- Design, installation & testing of the piling platform (by others)

3. Resources

Management / Supervision

1no Operations Director – Pat Fisher - 07880007869 (visiting)
 1no Contracts Manager – Tim Davidson 07557 284916 (Visiting)
 1no Senior Supervisor – Andy Beddoes 08724816677 (Visiting)
 1no working foreman – TBA

Labour

1 No Pile press operator / Working Foreman
 1 No Piling operative
 1 No Piling Welder
 1 No Crawler Crane operator
 1 No Pre auger operatives

Plant & Equipment

1 No 50T Crawler Crane
 1 No Tosa WP150 Pile press (or similar) complete with power pack
 1 No Water Jetting unit c/w water storage skip
 1 No Diesel Bowser
 1 No weld set
 1 No storage container unit
 Oxy propane Burning Gear
 1No Biguma boiler

Materials

To be confirmed after design completed. 159no piles between 8 and 12m long.
 Diesel – to be stored in 110% bunded bowser

| 4. Training | | | | | |
|--------------------------------|-----|----|-------------------|---------|----|
| Training Certificates Required | | | | | |
| | Yes | No | | Yes | No |
| Pile Press | ✓ | | Slinger/signaller | ✓ | |
| Mobile crane | ✓ | | SSSTS | Foreman | |
| Pre Auger rig | ✓ | | Banksman | ✓ | |
| | | | | | |

| 5. Method of Works |
|--|
| <p><u>Environmental</u></p> <p>Environmental aspects specifically considered while undertaking the works are as follows:</p> <p>Contamination of Ground/watercourse by Diesel – Drip Trays and Spill kits to be available within vehicles around site and within the site compounds.</p> <p>All refuelling to be carried out in accordance with Kier site fuelling procedures.</p> <p>Contamination of Ground/watercourse by hydraulic oils – Bio degradable oil to be used, all hoses inspected daily before use.</p> <p>Noise and vibration – Use of vibration-free steel pile installation equipment.</p> <p>All equipment to be in good condition and well maintained.</p> <p>All plant equipment turned off when not in use.</p> <p>All bunded systems for the storage of oils & fuels and chemicals must have a 110% storage capacity in regards to the container.</p> <p>All spills however minor are to be reported through the Project/ Site Manager.</p> <p><u>Subsurface Infrastructures</u></p> <p>The probing for the sheet piling and the subsequent installation of the sheet piles is unlikely to have any effect on the sub surface infrastructures because they are in Greenwood Place.. See Appendix D for plans of the works. Proposed basement structure over 3m away from Thames Water sewer.</p> <p><u>Waste Management</u></p> <p>There will be no hazardous waste produced during the normal sheet pile installation process.</p> <p>In the event of a diesel spill, or any other incident relating to diesel / oils, then the spill kits will be utilised as described above. The used spill kits will be disposed of as Hazardous Waste. In this event, a specialist waste contractor will be employed by KSP.</p> <p>Other general waste (such as paper/packets/wrappers, etc) will be disposed of in the site waste recycling facilities provided by Erith.</p> <p><u>PPE</u></p> <p>All site personnel will be provided by KSP with all necessary PPE to carry out their duties.</p> <p><u>Minimum standards:</u></p> <p>Safety Helmets, Safety Footwear, High Vis Vests, Flame Retardant Overalls, Gloves (Polycy). High Vis Trousers. Welding and burning mask depending upon task</p> <p>All KSP Operatives will wear eye protection at all times on site (Uvex).</p> <p>All High Viz PPE will be branded in accordance with the approved logo only.</p> <p>The use of non-approved PPE is not permitted at any time.</p> |

Permits (to be obtained just prior to working on site)

Prior to commencing works on site, the following permits will be obtained by the KSP Foreman:

All operatives to attend a Kier site induction prior to commencing works.

1. Permit to Load Crane platform (Working Platform Certificate)
2. Permit to Work / break ground / location of services
3. Hot Works Permit

No works are to commence on site until all necessary permits/ permissions are in place and understood by all personnel involved with the works.

Unloading

1. Prior to work commencing Kier must issue the permit to load the crane platform, the permit to work and hot works permit.
2. All lifts and vehicle movements and offloading will supervised by the Piling Foreman / slinger banksman, Traffic marshal to escort the vehicle at all times from the access gate to the place of work.
3. Tag lines will be used to control the sheet piles during lifting if required.
4. Due care will be taken with regard to the crawler crane operating in close proximity to other operations on site. A Banksman will be with the crane during movements and all so during piling he will ensure that no un-authorised personal enter the work area.
5. An exclusion zone, formed by pedestrian/crowd barriers or similar, will be erected by KSP for use during unloading of KSP deliveries only.
6. The crawler crane will be set up immediately in front of the work area, on the crane platform. The piling equipment and piles will be delivered and off-loaded adjacent to the works.
7. The piles and equipment will be stored in the designated stockpile area of the works.
8. Piles are delivered to site and stored in bundles, (approx 5T per bundle).
9. The KSP Slinger will ensure the bundles of piles are slung correctly and lifted using the correct 2 leg chains.
10. All lifts will be under the supervision of the KSP Slinger Signaller and will be carried out in accordance with the lifting duties of the crawler crane.
11. A rigid handrail system is to be used during unloading of all delivery wagons.
12. All delivery wagons will be fitted with a fall arrest / handrail system prior to arrival on site.
13. In addition, a handrails system will be stored on site, and fitted to each delivery wagon upon arrival if required.
14. The handrail uprights will be fitted from ground level.
15. When complete, the handrail system offers full edge protection, and therefore does not require operatives to wear harnesses, etc.

Sheet pile installation works - Tosa Silent Pile Press

Note, During Sheet pile installation works there may be a requirement to work at height, if a sheet pile need to be cut down above the chuck of the machine or for any access issues. A MEWP/Cheery picker will be provides and only trained and competent personal can operate.(Item covered on Risk Assessment)

1. The steel sheet piles will be installed from a platform prepared by others and maintained by Kier. All pile locations will be cleared of obstructions and suitably backfilled by others in advance of the piling works.
2. The sheet pile lines will be set out by Keltbray KSP by means of steel pins driven into the ground.
3. Prior to rigging the mobile crane a signed Working Platform Certificate (WPC) will be in place for the piling platform and the haul roads to be utilised around the piling area.
4. Prior to penetrating the ground a permit to dig must be issued to Keltbray Piling (sheet piling).
5. On commencement of sheet pile installation , the ground conditions in the first pile position will be checked against the site investigation information. Any discrepancy will be reported immediately by the Site Foreman to our Contract Management.
6. Spill kits must be positioned close to the works at all times.
7. All refuelling must be undertaken in the areas designated by Kier.
8. All fuel storage is to be in suitably bunded and secure bowsters, Complete with drip trays and fire extinguishers with in the vicinity.
9. All lifts will supervised by a slinger banksman, and tag lines will be used to control the sheet piles during lifting at all times.
10. Pile installation records will be kept and a copy given to Kier weekly, any standing time will be issued at the end of the day for approval.
11. Factors that may affect the work sequence are considered to be limited to the presence of obstructions or other unforeseen factors. Otherwise, works are programmed to continue in a linear fashion without interruption in the programmed sequence. Any change in drivability of the sheet piles will be reported to KSP Contracts Manager and then reported to Kier. If for any reason a change in sequence is require this must be issued to KSP Contracts Manager.
12. In the event of sheet pile refusal, it may be considered necessary to re-auger the proposed sheet pile position by use of the auger rig to verify any obstructions or to re-loosen ground should this be required. This will be carried out in accordance with the methodology described above.
13. The sheet piles are to be driven to the required level as set out by Keltbray KSP site engineer. The Tosa Pile Press requires 500mm clearance at the top of each sheet pile for the installation process.
14. It should be noted that if there are any of live services close to the proposed pile line, KSP site staff will expose and mark these services, and discuss all with the KSP Piling Foreman prior to the issue of a Permit to work/dig and works commencing.
15. Once the plant has arrived on site the Tosa and power pack will be offloaded, once at ground level the operative will put on his harness and using the step on the machine he will step up and clip on (Drop of 1.0m) once in position the hoses will installed to back of the machine and back to the power pack.
16. The crane will be set up immediately in front of the work area, on the crane platform. The piling equipment and piles will be delivered and off-loaded and stored adjacent to the works or even with-in the cofferdam.
17. The piles and equipment will be stored in the provided works area.

18. A firm and level platform, measuring 5.0m x 5.0m, will be provided for KSP, this will either be directly on the pile line or at 90 degrees to the line. This reaction stand platform will be sited as close to the mobile crane as A Raised platform of 5.0m x 5.0m to be provided by Kier at first corner, 500mm below finished level of sheet piles
19. The Tosa silent pile press reaction stand will be positioned close to the end of the pile line and made ready for use, then weighted down with approx. 24 tonnes of kentledge each block weighing approximately 4t. (see attached picture for set up)





20. The first pile will be pitched into the pile press and driven to level by a sequence of hydraulic pressing for the length of each ram stroke.
21. During sheet pile installation works, each sheet pile being pitched into the hydraulic chuck of the Tosa pile press the mobile crane will only be released from the mobile crane lifting shackle once the sheet pile is fully clutched into the previously installed sheet pile and is fully clamped into the hydraulic clamp of the Tosa pile press.
22. The second pile will then be driven. Before reaching final penetration the self-moving procedure will be instigated. Once the pile press has moved forward one pile, the second pile will be driven to final level.



23. Once the first three 'dummy' piles have been installed from the reaction stand, the stand will be dismantled, the kentledge blocks will be lifted off the reaction stand and stored in the middle of site prior to loading away

24. The reaction stand will then be lifted away from the work area.



25. After each pile is installed, a length of temporary weld approximately 75mm is used to weld each installed sheet pile to the previously installed sheet pile. Welding screens will be used at all times during these temporary welding works to ensure that other site operatives and trades do not have a line of sight to the welding process.
26. Welding curtains are made from a PVC Vinyl. Certain curtains will come equipped with steel rails or KSP will install to a crowd barrier.
27. Welding screens will be used at all times, and moved as the works progress.
28. The sheet piles will be installed in the direction which will be detailed on the site sketch, sheet piles will be lifted to the Tosa by use of the crawler crane working on the crane platforms.

Lifting Piles

1. Piles are delivered to site and stored in bundles of 5t
2. Ensure the bundles of piles are slung correctly and lifted using the 2 leg chains 7.5t.
3. Single horizontal piles should be lifted using two pile slippers, one positioned on each end of the pile to be lifted. The slippers are attached to the lifting gear using safety bow shackles, ensure that the R clips are serviceable and in position.
4. Take care to ensure hands and fingers are away from the pile / slipper as the pile is lifted.
5. There will be one designated Slinger Signaller in charge of all lifts. (CPCS Slinger)
6. The Slinger Signaller duties will be as designated by Lift Supervisor.
7. All lifts will be sighted, there is no requirement for blind lifts. If clear sight lines are not available then no work to proceed, and Appointed Person and Lift Supervisor will assess the further requirement for lifting, with Lift Plan amended as required prior to further works.
8. All lifts will be controlled by use of hand signals carried out by trained Slinger Signaller. There will be no requirement for a radio system due to the relative close proximity of all lifting operations throughout the unloading and sheet pile installation works.
9. The qualified Slinger Signaller will sling the bundle, check the bundle, and monitor the lift at all times as per Slinger Signaller procedure.
10. If in doubt, no lifting will be undertaken without consulting the Lift Supervisor in the first instance.

Pitching Piles

1. If shackle holes have to be burned in the pile, sharp burrs should be removed to prevent damage to shackle pins.
2. Remote release pitching shackles must be used to lift the piles. The pitching shackle is attached to the lifting gear using a safety bow shackle, ensure that the R clip is in good condition and in position.
3. The pitching shackle is manually positioned on the top of the pile, and the pin is engaged through the pitching hole using a hammer.
4. When using a Euro Ground Release Shackle, prior to lifting the pile, ensure the following;
 - a. the pin has been correctly fired through the pile-pitching hole
 - b. the rope attachment is as short as possible, free from knots and affixed to the pile to prevent snagging
 - c. the safety ring (the largest diameter ring) is placed over the barrel assembly. This should ensure that no pull on the release wire can be achieved without removing the ring from the barrel first.
5. The sheet pile must not be lifted vertically without first checking that the pin is properly engaged through the pitching hole of the sheet pile.
6. If windy conditions make the handling of the sheet piles difficult, work must stop until the responsible person has been consulted and a safe method of continuing the work has been devised.
7. The guidance for upper wind speeds for pitching piles is 11 m/s (approx. 26mph).
8. The pile is then lifted vertically by the crane and offered into the chuck of the Tosa.
9. A Piling Operative, working from the working platform will guide the sheet pile into the chuck of the Tosa.

10. **NOTE if site conditions change:** If there is a risk of falling more than 1.2m when pitching the pile into the chuck then a risk assessment must be carried out for working at height. Access to the chuck can be by ladder, if the ladder hazard assessment is followed (properly footed etc – see above) or by the use of a MEWP to gain access to the chuck. (If a ladder is to be used then a ladder permit must be issued prior to use)
11. When the Tosa Operator has guided the pile into the clutch of the previously installed pile and the pile is secure in the Tosa chuck by closing the hydraulic jaw, the Piling Operative then pulls on the rope to release the pitching shackle from the pile which is vertical in the chuck of the Tosa.
12. The crane slews the pitching shackle away back to the pile stockpile in order to pitch another pile.

Corner piles

1. In order to turn corners dummy piles are installed, in the opposite direction to the direction of the turn. The Tosa uses the dummy pile to install the sheet piles at the corner.
2. When piles have been installed away from the corner the Tosa will be lifted by the crane, placed on the piles closest to the corner and the dummy piles will be extracted.

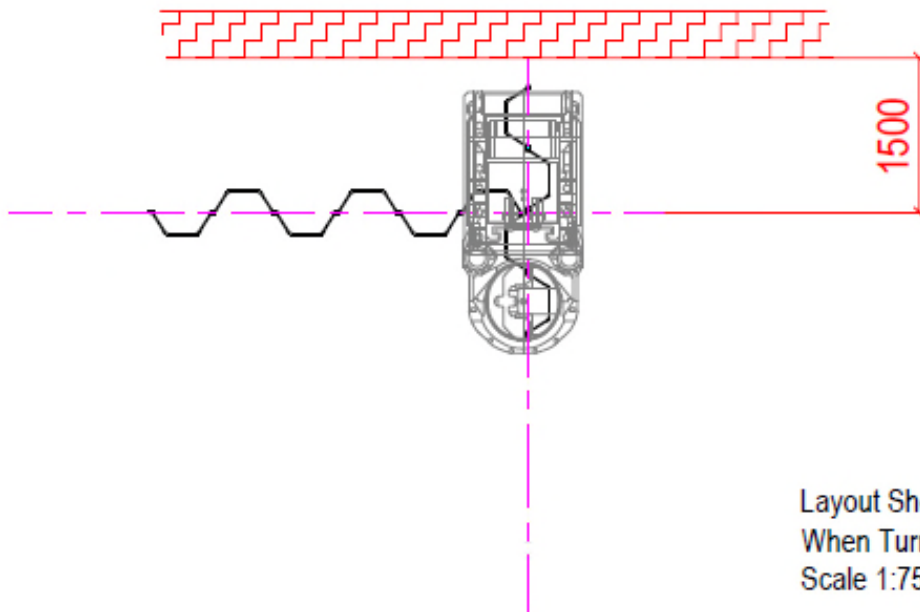

Layout Showing Tosa Clearance
When Turning Corner
Scale 1:75

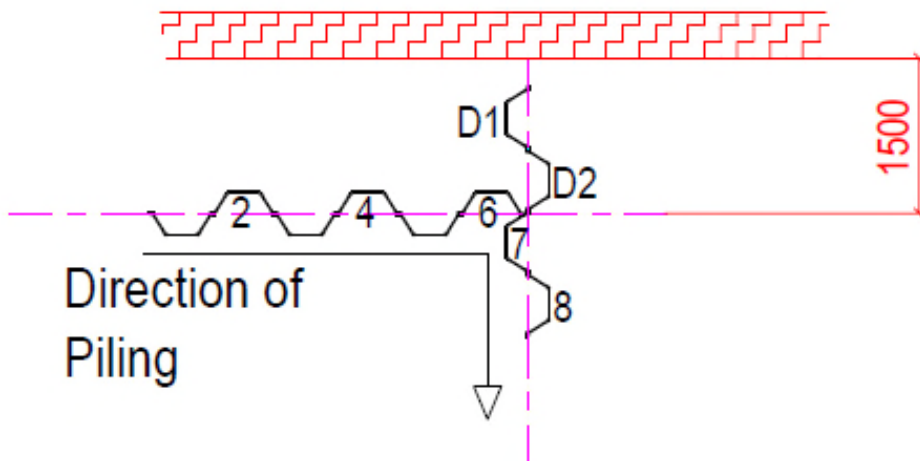

Fabrication of corner piles

1. Corner piles (lengths vary will be constructed using the piles on the stockpile area. The corner details are shown on the drawing, however site measurements will be taken to ensure correct fabrication.
2. The corner piles will be fabricated by welding a clutch piece along the length of the pile at the positions specified on the drawing.
3. The corner piles will be fully welded on the inside of the corner utilising a 6mm fillet weld. The outside of the corner pile will be welded with a 100mm long 6mm fillet weld every 300mm.
4. The corner piles will be fabricated using manual metallic arc procedures and experienced qualified welders.

Water Jetting.

1. When water jetting, a small diameter steel pipe (lance pipe) is fixed by the welding of several clips into the middle of the pan of each pile. This is done when the pile is horizontal in the storage area. The top plate is welded to the top of the pile.
2. The lance hose is then attached to the lance pipe and to the water jetting unit. The lance pipe safety wire is then attached from the lance hose to the lance pipe. If the hose comes free during operation, the safety wire will prevent the lance hose from whipping around until the jetting unit can be turned off.
3. The pile is lifted as above, using the pitching shackle. The pitching hole may have to be flame cut in the leg of the pile, due to the lance pipe being in the middle of the pile pan.
4. As the Tosa pushes the pile into the ground, water is drawn and jetted into the ground at the toe of the pile. This action loosens the strata in front of the pile enabling it to be pushed into the ground. The Pile Operator regulates the water supply.
5. When the water supply is turned off, the ground settles to its original state, as is evident from the reaction obtained from the previously driven piles. Once the pile is driven the pipe is recovered and re-used.
6. The Tosa Operator, clamps the hydraulic jaws onto the lance plate and by pulling the plate and lance pipe up breaks the weld which fixed the plate to the top of the pile.
7. A Piling Operative, working from ground level, will attach the pitching shackle to the lifting eye on the top of the lance by use of the hanging wire sling. The wire sling avoids the need for works at height.
8. **NOTE if site conditions change** If there is a risk of falling more than 1.2m when attaching the pitching shackle then a risk assessment must be carried out for working at height. Access to the chuck can be by ladder, if the ladder hazard assessment is followed (properly footed etc – see above) or by the use of a MEWP to gain access to the chuck. (If a ladder is to be used then a ladder permit must be issued prior to use)
9. The crane then pulls the lance out of the ground and lifts it clear of the chuck. The lance is then slewed round to the pile storage area to be attached to the next pile to be installed.
10. When water Jetting the head level in the water tank will be monitored during each sheet pile installation, the will then be recorded and the Contracts Manager will convert in to Litres used per pile over the duration.

Pre-Auger / Soil Loosening

The Proposed soil loosening will be carried out using an EM400 or similar. The EM400 will mobilise to site on a step frame low-loader.

1. The pile locations will be pre-augered by a EM400 auger rig working from a platform prepared by others and maintained by Kier. All pile locations will be cleared of obstructions and suitably backfilled by others in advance of the piling works.

2. Prior to installation of the sheet piles with the Tosa pile press, the proposed pile lines will be pre-augered by use of the EM400 using 400-450mm diameter auger flights.
3. The pile line will be augered at 600mm centres to correspond with the pile clutch positions.
4. The auger will be screwed into the ground to the ground in 1 or 2m sections of flights until the required level is reached and then back screwed to loosen the ground.
5. At all times the auger will be back screwed in such a manner that the minimum amount of material is removed from the auger position.
6. The Banksman will check the position of the auger tip over the setting out pin. Final adjustment of level and verticality of the rig mast will then be undertaken. The auger tip will be lowered to the ground by the Rig Operator and the Nominated Banksman, the rig instrumentation will be re-set and pre-augering of the ground will then commence.
7. The sheet pile lines will be set out by Kier by means of steel pins driven into the ground. All setting out will be to centreline of sheet piles.
8. Prior to rigging up a signed Working Platform Certificate (WPC) will be in place for the piling platform and the haul roads to be utilised around the piling area.
9. Prior to penetrating the ground a permit to dig must be issued to Keltbray –Sheet Piling (KSP).
10. On commencement of pre-augering , the ground conditions in the first pile position will be checked against the site investigation information. Any discrepancy will be reported immediately by the Site Foreman to our Contract Management.
11. Due care will be taken at all times with regard to any existing live services and structures immediately adjacent to the area of work.
12. The position of the auger rig will be under the supervision of the slinger banksman at all times.
13. During withdrawal of the auger flight, all operatives will take due care to avoid falling debris.
14. As augering proceeds, all operatives will take due care when working near to augered areas, as the augering process may leave open holes at ground level. Kier is to provide an excavator to level spoil material from the augering as required.
15. During the augering process, the auger flight may become subject to natural wear and tear, and may require period repairs by use of welding. When this is required, the above procedure for 'Flame Cutting and Welding' will be followed.
16. Upon completion of the augering works, the auger rig will be loaded onto a low loader and demobilised from site.

Welding works to steel sheet piles

Welding works – general

29. Prior to works commencing every day a Hot Works Permit must be issued to Keltbray Sheet Piling.
30. Spill kits must be positioned close to the works at all times.
31. All refuelling must be undertaken in the areas designated by Erith.
32. All fuel storage is to be in suitably bunded and secure bowsers.
33. All lifts will supervised by a slinger banksman, and tag lines will be used to control the sheet piles during lifting if required.

34. It should be noted that if there are any of live services close to the areas of welding, Keltbray site staff will expose and mark these services, and discuss all with the KSP Piling Foreman prior to works commencing.
35. Welding screens will be used at all times during these temporary welding works to ensure that other trades and site users do not have a line of sight to the welding process.
36. Welding screens will be used at all times, and moved as the works progress.

Flammable Liquids and Gases

Gases are supplied in pressurised cylinders (bottles) and should be handled with great care in accordance & guidance of the latest legalisation. Flammable liquids burn when mixed with the oxygen part of air, so keep them apart by keeping lids closed.

1. Most obvious risk is fire and/or explosion. Keep all flammable liquids and gases in proper containers clearly labelled.
2. Store fuel gases and liquids securely away from extremes of heat and sources of ignition. They should also be stored separately from other things that burn readily, and anything labelled as oxidising.
3. Take special care when transferring flammable liquids and connecting and disconnecting gas cylinders or fittings.
4. With flammable liquids the least exposure to air the better. When transferring use a pump, a pouring spout or a funnel. When using gases all appliances connected to the system must be turned off individually.
5. AVOID SOURCES OF IGNITION. There are the obvious ones : naked flames, lighted cigarette, cigar or pipe, and there are the not so obvious ones : electrical equipment, hot materials, heaters that do not show flames, sparks from cutting or grinding.
6. Most flammable gases that we use are heavier than air. When they escape, like water, they try to find the lowest level. Escaped gases will follow trenches, drains etc, and could become someone else's fire.
7. Flammable liquids usually evaporate. Without enough ventilation there could be enough vapour to start a fire some distance from the point of escape. Always make sure there is good ventilation.
8. Keep all flammable liquids and gases away from the working area when not being used.
9. Refuelling of equipment is to be in the dedicated refuelling area which will have absorbent drip trays (plant nappies) for refuelling over and spill kits to hand. Refuelling of tools and equipment is to be carried out over the plant nappies in the refuelling area only. Absorbent material in plant nappies are to be disposed of as hazardous waste as required.
10. When refuelling plant, an absorbent drip tray (plant nappy) will be placed on ground by the fuelling point to absorb any spilt fuel.
- 11. In the event any fuel is spilt outside of the plant nappy spill kits, refueling is to be stopped immediately spillage procedure on COSHH store is to be followed and the Kier team are to be notified.**

Controls & Monitoring

1. During the piling operations, should the methodology require to be altered an amendment will be made and issued. This can consist of a hand written alteration within the body of this document, so long as signed and dated by an appropriate person and re-briefed, to minimise any delays to the activities.
2. Each pile will be checked for verticality as work proceeds by KSP, by use of the levelling device on the rig and a hand help spirit level on the sheet pile during installation.

3. KSP shall ensure that the piles are installed in accordance with the pile schedule and relevant drawings.
4. Installation logs will be kept for every sheet pile installed,
5. Additional detail / records to be kept of any piles which fail to achieve the required drive depth as required.
6. KSP will produce a Daily Record sheet detailing the daily events and activities on site, this will be submitted to Kier on a daily basis.

6. Logistics

- All vehicle movements will be controlled by a KSP traffic marshal from the gate location to the point of work.
- All Delivery to be booked in with the logistics manager 24hrs prior to commencing works.
- All vehicle deliveries will adhere to the site access as below.
- Sheet piles and equipment will be delivered on ridged wagons.
- Mobile crane self drive
- Before commencement of any works on site all operatives will receive a full site induction and must sign up to a method statement briefing sheet, a copy is included in appendix E
- Access to the work areas is to be provided by the main contractor from site access to all locations in accordance with the temporary works requirement. A minimum requirement is a stone built track minimum width 10.0m.
- Piling Platforms remain the responsibility of the Main Contractor, and are to be provided to cater for the following track pressures:

| Equipment | Max Pressure (kN/m2) | |
|------------------|----------------------|--|
| 50T Mobile Crane | 360 | |

- All traffic management for the delivery and offloading of equipment is to be provided by the Skanska, with KSP to bank and supervise movement of deliveries.
-

- Vehicle / pedestrian segregation is the responsibility of Kier, KSP are to ensure this is in place prior to unloading works commencing.
- All operatives and supervisors involved in the works must wear the PPE detailed above and receive a site induction.
- All protection works/ access works are to be completed and in place by the main contractor in advance of Plant Being delivered to site.
- **All Permits required are to be issued by the main contractor and accepted by KSP Foreman prior to any works commencing.**
- All delivery drivers are to report to the site supervisor/ foreman for instruction. At all times KSP transport / wagons will be sent to site with handrails fixed to the bed of the trailer, with a short (footed) ladder used to access the bed of the trailer.
- All personnel entering the site must sign in the attendance book held with the main contractor.
- All materials are to be stacked within radius of the Mobile crane during installation to reduce plant movements around the site. All piles will be stacked to the rear of the crane mat or within the proposed cofferdam.

7. Hazards / Risks

Keltbray Management having carried out a Risk Assessment and have identified the following

The following hazards have been identified as associated with the planned work activity;

- Use of mobile cranes
- Lifting & loading equipment
- Lifting piles with Q.R.S.
- Banking and Slinging
- Working in public places
- Oxygen / acetylene / propane burning
- Welding
- Re-fuelling plant
- Pre-Augering
- Manual handling
- Use of abrasive wheels and disc cutters
- Use of Tosa Quiet Piler
- Working at height / unloading vehicles
- Use of biguma

COSHH

- Grease
- Hydraulic Oil
- Diesel
- Petrol
- Mineral Oil

Housekeeping

- Keltbray Piling operatives will have a duty on site to maintain a tidy and safe working area.
- This will apply in both the construction site and the welfare area. Operatives will ensure that they assist in the tidiness of the site by ensuring work area is clear and any rubbish is placed in the designated skips on site.

| 8. Control Measures (Permits, Exclusion Zones, PPE etc.) | | | | | |
|--|-----|----|------------------|-----|----|
| Permits Required | Yes | No | Permits Required | Yes | No |
| Hot works | ✓ | | COSHH | ✓ | |
| Lift plan | ✓ | | Noise | ✓ | |
| Excavation/dig | ✓ | | Manual handling | | ✓ |
| Confined space entry | | ✓ | Piling platform | ✓ | |
| Vibration | | ✓ | | | |

Further Control Measures / Security Requirements.

Due to the nature of the works being carried out on the site, no unauthorised personnel are to enter the piling area without permission from the site manager or the supervisor in charge of works.

As indicated above prior to the works being carried out a piling platform certificate will be required piling mat and any utilised haul roads

| Personal Protective Equipment | Yes | No | | Yes | No |
|-------------------------------|-----|----|--------------------|-----|----|
| Safety Helmet | ✓ | | Gloves | ✓ | |
| Protective Footwear | ✓ | | Hearing Protection | ✓ | |
| High Visibility Clothing | ✓ | | Overalls | ✓ | |
| Eye protection | ✓ | | Body Harness | ✓ | |
| Face Respirator | | ✓ | Other | | ✓ |

| Equipment To Be Used | Yes | No | Equipment To Be Used | Yes | No |
|----------------------|-----|----|----------------------------|-----|----|
| Lifting | ✓ | | Vibrating pack | | ✓ |
| Mechanical hoist | | ✓ | Excavation shoring/casings | | ✓ |
| MEWP | | ✓ | Ventilation Equipment | | ✓ |
| Ladder | ✓ | | CAT | | ✓ |
| Hoist | | ✓ | Mechanical tools | ✓ | |
| Test Equipment | | ✓ | Excavation shoring | | ✓ |
| Task Lighting | ✓ | | Lifting slings/chains | ✓ | |
| Scaffolding | | ✓ | Mechanical plant | ✓ | |
| Mobile scaffolds | | ✓ | | | |

9. Emergency Arrangements

| First Aid Measures required | |
|-----------------------------|----------------------------------|
| Trained first aider on site | Site Foreman / Kier |
| First aid kits on site | In stores cabin and site offices |
| Rescue | |
| By | Not applicable |

Appendix B - Typical Plant Layout for Tosa works.

Typical Site Layout - Initial Setup
Scale 1:125

NOTES

GENERAL

- DO NOT SCALE FROM THIS DRAWING.
- All dimensions are in mm and levels are in m OD unless otherwise stated.

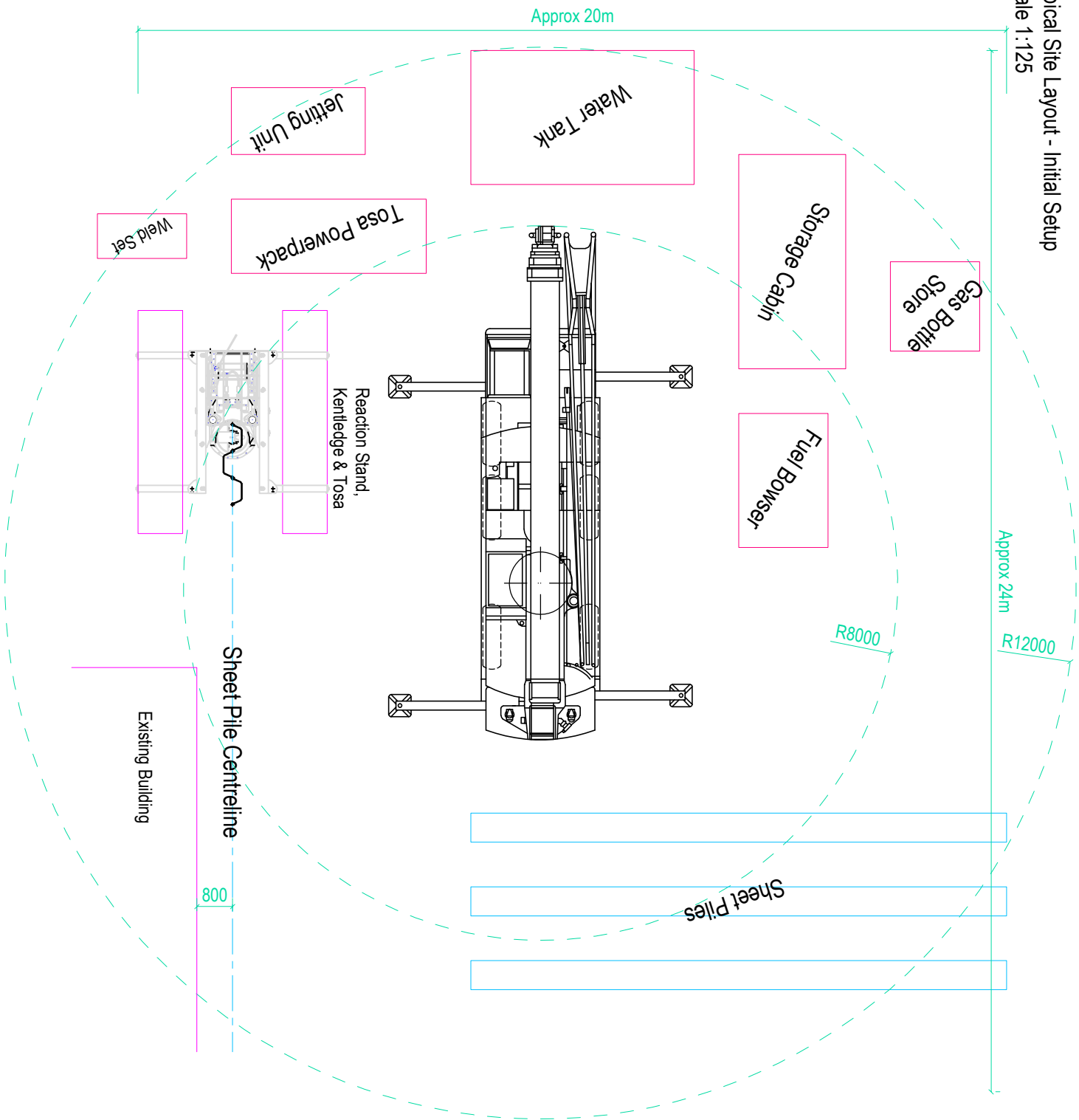

| | | | |
|----|----------|-----------------|-----------|
| 02 | 18.05.16 | Revisions made. | DC |
| 01 | 11.05.16 | Revisions made. | DC |
| 00 | 10.05.16 | First Issue | DC |
| | | | Dm Dsn At |

Keltbray Sheet Piling

St. Andrew's House, Esner, Surrey, KT10 9TA
Tel: 020 7643 1000 Web: www.keltbray.com

Job Standard Details

Title Typical Site Layout

Status PRELIMINARY

Job No. KSP Drg.No. SD04 Rev. 02

Web No.

Appendix C - Plant Details

Please note that these are typical plant details for the silent piler and the noise and vibration outputs will be comparable to the details noted.

Tosa Still Worker WP150

The development of hydraulically - powered, static-load sheet pile pressing equipment, in response to severe constructional and environmental problems in high-density inner city areas, provides a very quiet method entirely free from vibration.

This process of sheet pile installation or extraction produces low levels of noise and no vibration, which allows piling in built-up areas and in close proximity to existing services.



The Silent Piler Machine drives and extracts 600mm 'U' profiles, with up to 150 tonnes pressing capacity.

Self travelling means only a small crane is required for pitching, allowing works in low headroom areas.

Radio controlled and no piling gates required means a productive safe working environment.

The Silent Piler machine is fully able to turn corners and install sheet piles on curves.

In order to commence the works the reaction stand is positioned and our kentledge positioned onto the reaction stand. The kentledge gives the reaction force required to install the first three piles.

The first three piles may be shorter than the actual pile length required. If shorter piles are used they will eventually be extracted and replaced with the required longer piles.

Once the first three piles are installed the Tosa “walks” onto the three piles. The clutches of the three piles are welded together (approximately 100 to 150mm of weld) to ensure the three pile act together to give the reaction to install the fourth pile.



Once the Tosa is positioned on the three piles the kentledge and the reaction stand are cleared away from the working area. The Tosa then operates from the top of the installed sheet piles.

As piles are installed the Tosa is “walked” on and the three piles the pile press is positioned on are welded together. This general principal is adopted as the installation progresses.



Water jetting is sometimes used to aid the installation. A small diameter lance pipe is fixed using welded clips to the pan of the pile to be installed. There is a nozzle at the end of the lance pipe, positioned above the toe of the pile.

The hoses are attached from the top of the lance pipe to the jetting unit. When the pile is positioned vertically in the chuck of the Tosa the water is turned on and the installation commences with the Tosa pushing the pile into the ground with each stroke.

| Noise Analysis Form | | | | | | | | | | |
|---|--------------------|---|---------|------|-------------------------|------------------------|------|--|------|-------|
| Contract/Location/Area Heygate Estate, 1054 | | | | | Assessment No. KBY 001 | | | | | |
| | | | | | Assessed By: C. Fundrey | | | | | |
| | | | | | Date: 16/04/2015 | | | | | |
| Description of Noise Source Sheet Piling with Tosa WP150 Still worker, assessment taken 1m from noise source at same distance of operatives (See photos attached on the following pages) | | | | | Type of Noise | | | | | |
| | | | | | Octave | | | | | |
| Location of Meter | Duration of Survey | Duration of Noise Source | SPL Max | LAEQ | LEP'd | Worker Numbers Exposed | | | | |
| 1 meter away Tosa WP150 Still Worker. | 2 min 13 sec | 2 min 13 sec | 93.5 | 78.3 | 79.3 (10 hrs) | 1 | | | | |
| Frequency Analysis | | | | | | | | | | |
| Frequency (Hz) | 32 | 63 | 125 | 250 | 500 | 1000 | 2000 | 4000 | 8000 | 16000 |
| Reading dB (Z) | 42.9 | 60.8 | 65.5 | 69.7 | 72.0 | 71.9 | 71.4 | 66.6 | 62.8 | 53.7 |
| Assumed Protection Level | | | | | | | | | | |
| Noise Level at Operators Ear | | | | | | | | | | |
| Additional Information | | | | | | | | | | |
| Distance from source to 80dB(A) threshold | | N/A | | | Type of Meter | | | Casella 490 Sound Level Meter (Type1). | | |
| Distance from source to 85dB(A) threshold | | N/A | | | Date Calibrated | | | August 2014 | | |
| | | | | | Windshield Fitted | | | Yes | | |
| <p>Recommendations/Comments: A Casella Cel490 was used to carry out noise assessment in the working area for the purpose of noise assessment, setting up noise hearing zones and choosing the correct type of hearing protection.</p> <p>Note: Exposure less than 80dB</p> <p>The worker's daily noise exposure Lep,d is less than the first action level so no further action is required other than regular noise measurement, especially when there are any changes to the environment or machinery.</p> | | | | | | | | | | |
| Signature | |  | | | Date | | | 16/04/2015 | | |



Project: Kings Cross Gas Triplet Client: Henry Construction

Contract No: C20989

Vibration Monitoring Record Sheet

Readings to be taken twice a day (minimum), morning and afternoon,
and recorded on this sheet

| Day | Date | Time | Point Ref | Max Vibration Level Observed mm/s | Duration of Measurement | Operation Type | Weather Conditions | Name of Observer | Notes |
|-----|-----------|-------|-----------|-----------------------------------|-------------------------|-------------------------|--------------------|------------------|---------------------|
| Mon | 01-Dec-14 | 09:00 | DC5 | 1.47 | 20 mins | Sheet Pile Installation | Dry/Clear | G.Brown | 2m From Tosa DC5 |
| Mon | 01-Dec-14 | 14:00 | DC5 | 1.46 | 20 mins | Sheet Pile Installation | Dry/Clear | G.Brown | 2m From Tosa DC5 |
| Tue | 02-Dec-14 | 08:45 | DC5 | 1.70 | 20 mins | Sheet Pile Installation | Fine Rain | G.Brown | 2m From Tosa DC5 |
| Tue | 02-Dec-14 | 14:00 | DC5 | 1.74 | 20 mins | Sheet Pile Installation | Clear | A.Hamson | 2m From Tosa DC5 |
| Wed | 03-Dec-14 | 09:15 | DC5 | 1.62 | 20 mins | Sheet Pile Installation | Dry/Clear | A.Hamson | 2m From Tosa DC5 |
| Wed | 03-Dec-14 | 13:45 | DC5 | 1.65 | 20 mins | Sheet Pile Installation | Dry/Clear | A.Hamson | 2m From Tosa DC5 |
| Thu | 04-Dec-14 | 10:30 | DC5A | 1.74 | 20 mins | Sheet Pile Installation | Dry/Clear | A.Hamson | 2.5m from Tosa DC5A |
| Thu | 04-Dec-14 | 14:25 | DC5A | 1.82 | 20 mins | Sheet Pile Installation | Rain | A.Hamson | 2.5m from Tosa DC5A |
| Fri | 05-Dec-14 | 08:30 | DC5A | 1.79 | 20 mins | Sheet Pile Installation | Rain | A.Hamson | 2.5m from Tosa DC5A |
| Fri | 05-Dec-14 | 14:00 | DC5A | 1.69 | 20 mins | Sheet Pile Installation | Rain | G.Brown | 2.5m from Tosa DC5A |

Project: Kings Cross Gas Triplets Client: Henry Construction

Contract No: C20989

Vibration Monitoring Record Sheet

Readings to be taken twice a day (minimum), morning and afternoon, and recorded on this sheet

| Day | Date | Time | Point Ref | Max Vibration Level Observed mm/s | Duration of Measurement | Operation Type | Weather Conditions | Name of Observer | Notes |
|-----|-----------|-------|-----------|-----------------------------------|-------------------------|-------------------------|--------------------|------------------|---------------------|
| Mon | 08-Dec-14 | 08:20 | DC5A | 1.98 | 20 mins | Sheet Pile Installation | Dry/Clear | A.Hamson | 2m From Tosa DC5 |
| Mon | 08-Dec-14 | 13:40 | DC5A | 1.75 | 20 mins | Sheet Pile Installation | Fine Rain | A.Hamson | 2m From Tosa DC5 |
| Tue | 09-Dec-14 | 09:20 | DC6 | 1.92 | 20 mins | Sheet Pile Installation | Fine Rain | G.Brown | 2.5m From Tosa DC5 |
| Tue | 09-Dec-14 | 14:20 | DC6 | 1.94 | 20 mins | Sheet Pile Installation | Fine Rain | A.Hamson | 2m From Tosa DC5 |
| Wed | 10-Dec-14 | 10:00 | DC6 | 2.01 | 20 mins | Sheet Pile Installation | Dry/Clear | G.Brown | 2.5m From Tosa DC5 |
| Wed | 10-Dec-14 | 14:45 | DC7 | 1.93 | 20 mins | Sheet Pile Installation | Dry/Clear | G.Brown | 2m From Tosa DC5 |
| Thu | 11-Dec-14 | 09:15 | DC7 | 1.86 | 20 mins | Sheet Pile Installation | Dry/Clear | A.Hamson | 2.5m from Tosa DC5A |
| Thu | 11-Dec-14 | 13:45 | DC7 | 1.88 | 20 mins | Sheet Pile Installation | Dry/Clear | A.Hamson | 2.5m from Tosa DC5A |
| Fri | 12-Dec-14 | 09:00 | DC1 | 1.79 | 20 mins | Sheet Pile Installation | Dry/Clear | A.Hamson | 2.5m from Tosa DC5A |
| Fri | 12-Dec-14 | 14:00 | Dc1 | 1.77 | 20 mins | Sheet Pile Installation | Dry/Clear | G.Brown | 2.5m from Tosa DC5A |

Tosa Still Worker WP150

Water Jetting

Water jetting is primarily used to enable piles to be pressed into ground conditions that otherwise would be unsuitable for the Tosa Still Worker Silent and Vibrationless Pile Press. This could be due to either density (cohesive or granular soils) or stiffness (cohesive soils).

In order to significantly improve the installation of sheet piles into the above difficult ground conditions water jetting can be utilised. Water jetting also optimises the sheet pile section required.

Water jetting is effected by means of either a high strength steel jetting pipe (lance) attached to the inpan of the sheet pile. The lance system is shown below.

Jetting Lance in the InPan of a Sheet Pile

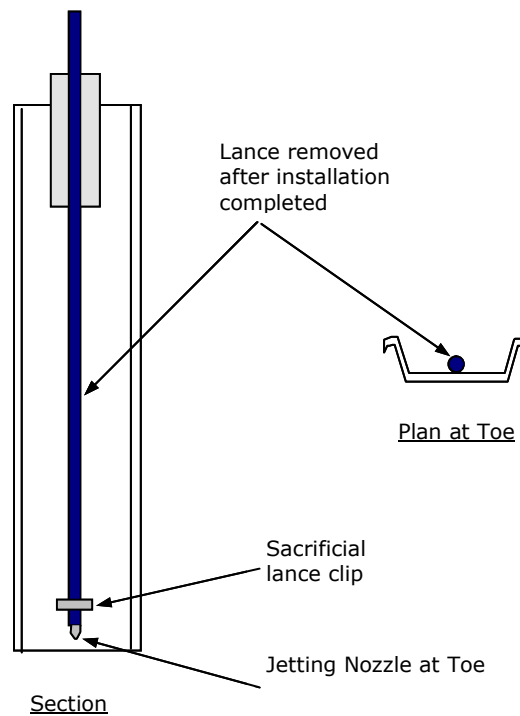

The jet is operated at low pressures in the initial stages of the installation to prevent excessive washout of soil particles. As the installation progresses, the jet is operated continuously throughout the installation to maintain a clear jet nozzle. The water pressure is adjusted in response to the ground resistance to enable the optimum penetration of the pile to be achieved with a minimum disturbance to the structure of the ground.

The Effects of Water Jetting

The possible effects of the water jetting operation on the sub soil structure may be cause of concern for Structural Engineers. To address this concern, we offer below a basic explanation of the water jetting operation on the soil.

Granular Soils

When piles of any type are installed into granular soils, most of the resistance to the pile penetration results from the creation of a pressure bulb in the soil at pile toe level.

Significant resistance can also arise from clutch friction caused by the granular particles becoming packed in the leading clutch during installation. Water jetting applied close to the toe of the pile, during installation will reduce these effects. Sealant, applied to the lead clutch, is often used with the water jetting to reduce clutch bind.

In fine and medium granular soils, the main action of the water jet is to locally increase the pore water pressure such that the inter particle friction in the soil is virtually eliminated, thus reducing the internal shear strength of the soil immediately under the pile toe.

In coarse granular soils, the main action of the water jet is to oscillate the particles reducing the resistance to pile penetration.

The water jet has further actions as the water returns to ground level. These are flushing out the leading clutch, reducing clutch friction when installing the subsequent pile and reducing skin friction on the pile being installed as some of the water returns up the face of the pile hence lubricating the pile/soil interface.

The water jetting operation does not significantly displace soil and large voids are not created. In very fine soils (for example silts) some migration of the silt particles can occur towards the ground surface as the water returns or into the voids in more coarse granular soils.

However in the predominantly silty soils of Japan, where water jetting is utilised extensively, no serious problems have been caused by loss of soil volume arising from the use of this technique.

On completion of the pile installation the water jet is turned off. The residual excess pore water pressure dissipates and the pore water pressure returns to normal almost immediately thus restoring the internal shear strength of the soil to its original condition.

The localised nature of the water jetting effect is illustrated below.

Toe of Sheet Pile

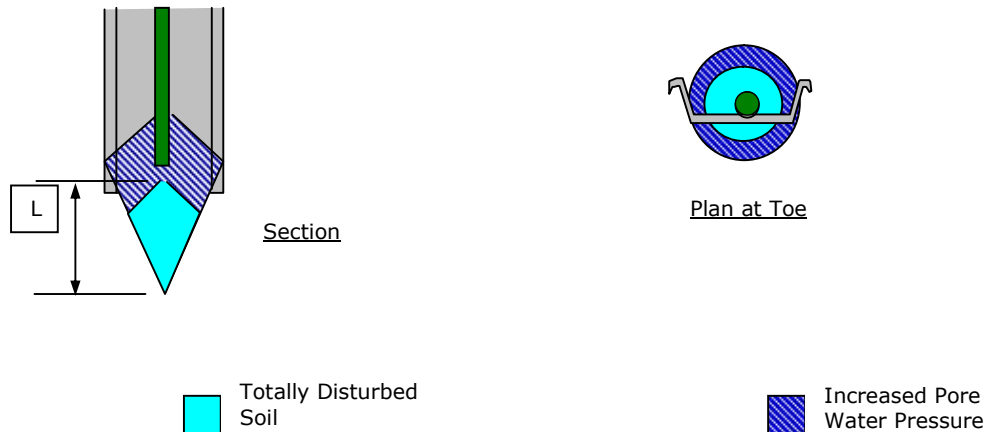

The depth of disturbance 'L' consists of a cone of very high pressure, roughly proportional to that of the jet pressure, within which, the soil structure is totally disturbed. This depth 'L' is a function of the density of the soil and the particle size distribution.

Outside of this primary cone there is an inverted cone where the pore water pressures are increased above the natural level, resulting in reduced soil strength. The volume of this cone is determined by the volume of jet flow rather than pressure and by the speed of penetration of the pile.

Cohesive Soils

When steel sheet piles are installed into cohesive soils most of the resistance to pile penetration results from shaft adhesion (skin friction) rather than end resistance. The closely fitting platelets in clay soils, as illustrated below, render the clay effectively impermeable therefore the action of the water jet cannot be to either oscillate the particles or to significantly affect the pore water pressure.

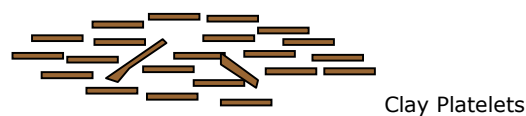

The impermeability ensures that the bulk of the water returns, to ground level or to the upper surface of the clay strata, up the shaft of the pile. The lubricating action of the returning water is clearly very efficient in reducing the amount of adhesion contributing to the pressing resistance whilst at the pile toe the water clearly has a localised softening/cutting effect which reduces the end resistance and eases the penetration of the pile.

The longer term effects of any localised softening of the clay affects the working of the sheet pile only in respect of movement and not in terms of overall stability as the full passive resistance will still be mobilised. However, the sheet pile wall will have to move slightly further than usual before the passive resistance is mobilised.

Pre-augering



Pre-augering is carried out in advance of sheet pile installation to loosen the sub soils to enable piles to be driven into ground conditions that might otherwise not be suitable for a sheet pile solution or would require an uneconomically heavy pile section.

The Bauer RTG RG 16T Telescopic Leader Rigs are fitted with either the MB20 or MB50 auger motors. A nominal 400mm diameter auger is then attached to the auger drive unit, the ground is then augered usually to the full pile depth at 600mm centres located at the position of the pile clutches, as shown in the sketch below.

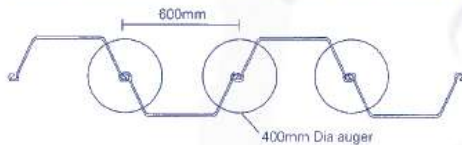

Typically the intention is to loosen the soil rather than create an empty bore. The auger flights are rotated into the ground one direction and counter-rotated to remove them leaving the sheared soil in place in the ground. A small amount of spoil is created to allow for the volume of the auger flights. This spoil needs to be removed from the pile line in advance of the sheet pile installation. Depths of up to 17.0m can be achieved using the MB50 motor.

The effects of pre-augering

- To locally disturb the soil to enable piles to be installed.
- The effect is short lived as soil is reconsolidated when the piles are vibrated or water jetted into the ground
- Can be used in advance of pile pressing techniques to reduce the size of pile required
- Can be used to reduce the need for water jetting
- Can assist in reducing the effects of ground-borne vibrations when used with vibratory techniques
- Can reduce the need for using an impact hammer to final drive piles
- Can help to locate under ground obstructions in advance of pile installation

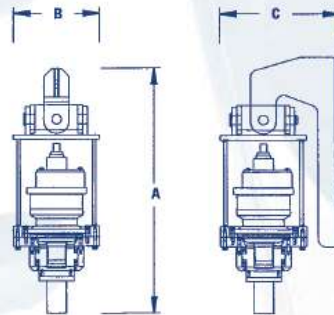

| AUGER MOTOR | MB 20 | MB 50 |
|--------------------------------|----------|----------|
| A Height | 1600 mm | 1880 mm |
| B Width | 540 mm | 710 mm |
| C Depth | 750 mm | 840 mm |
| Max. torque (300bar) | 20.0 kNm | 47.0 kNm |
| Max. torque (330 bar) | 22.0 kNm | 52.6 kNm |
| Max. pressure | 375 bar | 375 bar |
| Max. speed | 110 rpm | 80 rpm |
| Axial load (traction/pressure) | 160 kNm | 220 kNm |
| Hexagon socket SW | 80 mm | 120 mm |

ADVANTAGES

- Enables piles to be installed into difficult soils
- Improves installation rates
- Optimises pile section choice for better economy
- Very short term disturbance to the soils
- Reduced ground borne vibration
- Can help to achieve a limited toe into otherwise impenetrable strata

Appendix D - Site Constraints.



NOTES

- DO NOT SCALE THIS DRAWING ON PRINT OR ELECTRONICALLY. WORK FROM FIGURED DIMENSIONS ONLY.
- NO DEVIATION FROM THE DETAILS ON THIS DRAWING IS ALLOWED WITHOUT CampbellReith's PRIOR PERMISSION IN WRITING.
- READ THIS DRAWING WITH ALL ARCHITECT'S, SERVICE ENGINEER'S AND CampbellReith's RELEVANT DETAILS AND DRAWINGS. NB. SETTING-OUT DIMENSIONS AS PER THE ARCHITECT'S DRAWING TAKE PRECEDENCE.
- ALL WORK IS TO BE DONE IN ACCORDANCE WITH THE RELEVANT SPECIFICATIONS ISSUED BY CampbellReith, BRITISH STANDARD CODES OF PRACTICE, STATUTORY REQUIREMENTS AND THE CONTRACT DOCUMENTS.
- DRAWING STATUS:**
P - PRELIMINARY - EVOLVING DRAWINGS FOR APPROVALS, TENDERS, BILLINGS, ETC.
C - CONSTRUCTION - FULLY DEVELOPED DRAWINGS ISSUED UNDER INSTRUCTION FOR CONSTRUCTION
- SUITABILITY CODE:**
WORK IN PROGRESS:
S0 - WORK IN PROGRESS
SHARED (NON-CONTRACTUAL):
S1 - FOR COORDINATION, **S2** - FOR INFORMATION, **S3** - FOR INTERNAL REVIEW AND COMMENT, **S4** - FOR CONSTRUCTION APPROVAL.
DOCUMENTATION (FOR CONTRACTOR PURPOSES):
D1 - FOR COSTING, **D2** - FOR TENDER, **D3** - FOR CONTRACTOR DESIGN, **D4** - FOR MANUFACTURE / PROCUREMENT.
CONSTRUCTION:
A - FOR CONSTRUCTION, **B** - FOR CONSTRUCTION BUT WITH COMMENTS (i.e. AREAS IN ABEYANCE), **C** - COMPREHENSIVE REVISIONS REQUIRED

FOR BORED PILE LOADING REFER TO SCHEDULE 12291-CRH-GC-XX-SC-S-1000.
 FOR PILE SETTING OUT & CUT OFF LEVELS REFER TO SCHEDULE:- 12291-CRH-GC-XX-SC-S-1001.

SHEET PILE LOADING IS SHOWN ON THIS PLAN

| Status/Rev | Description | Date | By |
|------------|---|------------|-----|
| P5 | kN/m added to Line load notes on grid W | 12.08.2016 | NSG |
| P4 | All Sheet Pile Line loads revised, additional Line load notes removed. | 12.08.2016 | NSG |
| P3 | Pile Cap adjacent to grid E-02 rotated. Indicative Temporary works Sheet Piling & notes added. Piling load note revised. Piles 166 & 167 added. | 04.08.2016 | LEV |
| P2 | ISSUED FOR TENDER. Sheet Pile loads and Deane House loads added. | 05.07.2016 | AJT |
| P1 | ISSUED FOR TENDER | 27.06.2016 | NSG |

CampbellReith
 consulting engineers

LONDON 020 7340 1700 MANCHESTER 0161 819 3060
 SURREY 01737 784 500 BIRMINGHAM 01675 467 484
 BRISTOL 0117 916 1066 DUBAI 00 971 4345 7088
 www.campbellreith.com

Job Title: **GREENWOOD CENTRE**
 Client: **KIER**

PILING LAYOUT

| | | | | |
|-------|---------|------------|------------|----------------|
| drawn | date | scale @ A1 | C1 checked | CR Project No. |
| NSG | MAR '16 | 1 : 100 | | 12291 |

| | | |
|---------------------------|-------------|--------------|
| Dwg No. | Suitability | Status / Rev |
| 12291-CRH-GC-B1-DR-S-1000 | D2 | P5 |

Appendix E – Basement Plan and sections.

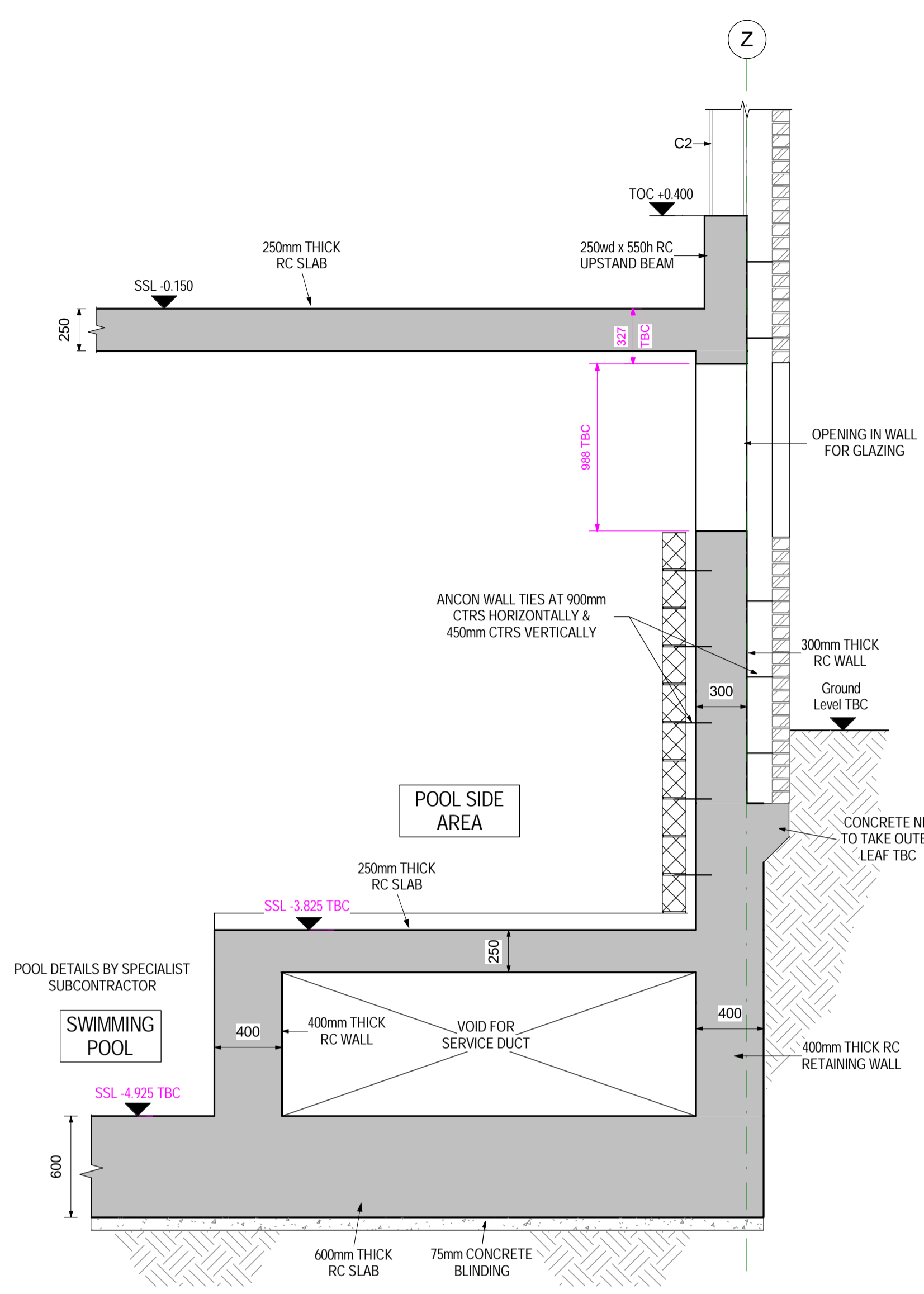

02 SECTION
1 : 25

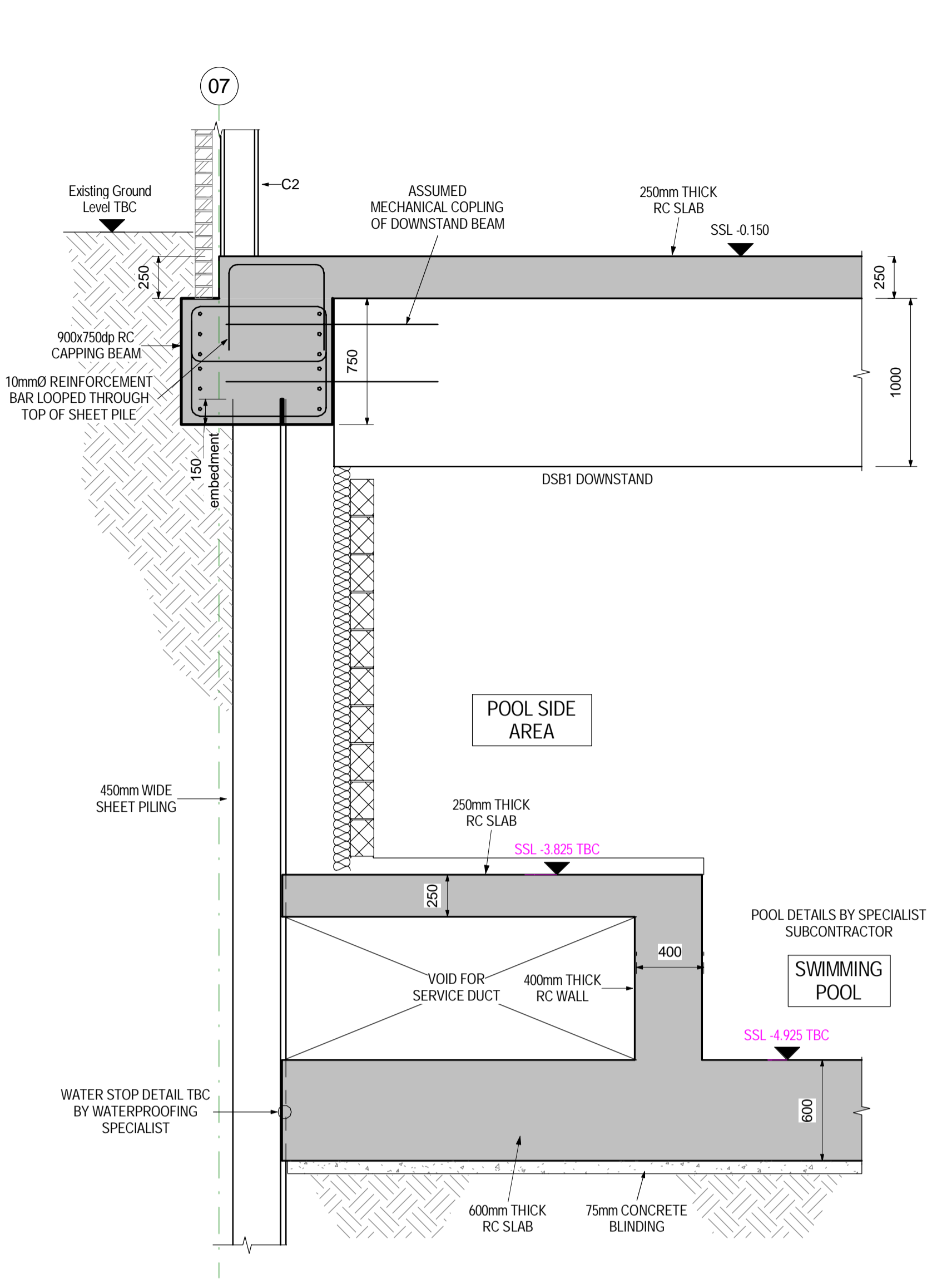

03 SECTION
1 : 25

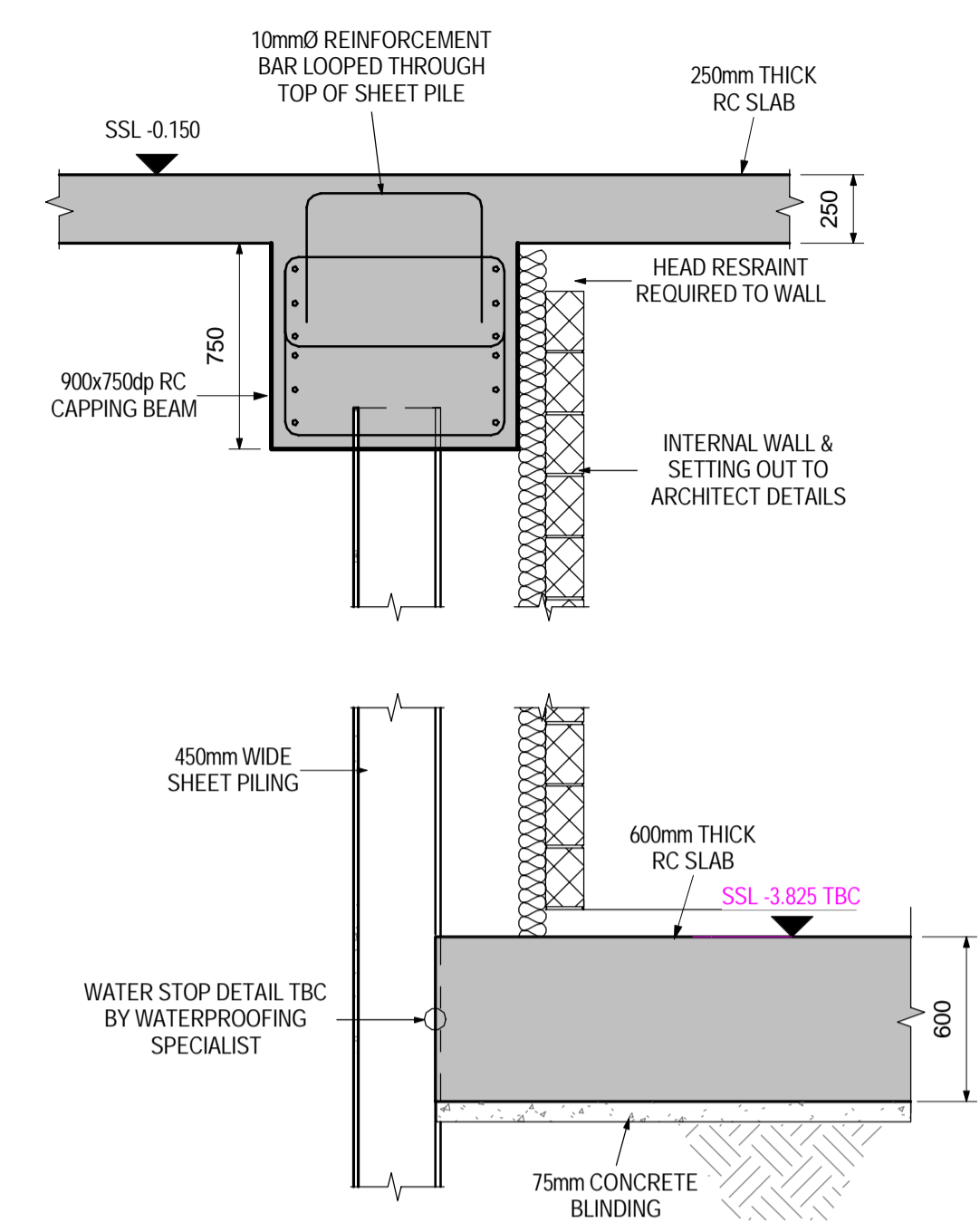

TYPICAL INTERNAL
CAPPING BEAM DETAIL
04 SECTION
1 : 25

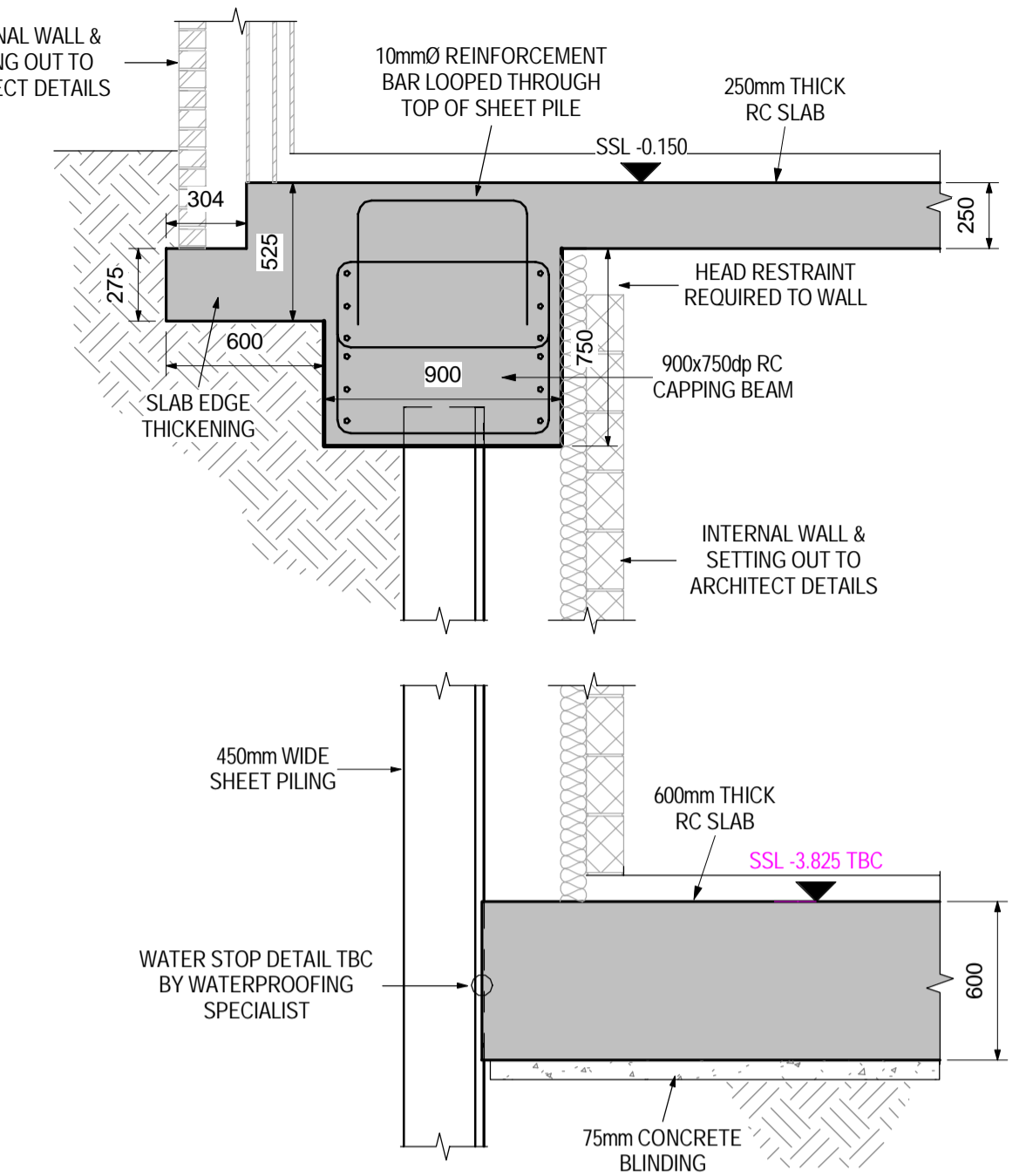

TYPICAL EXTERNAL
CAPPING BEAM DETAIL
05 SECTION
1 : 25

- NOTES**
- DO NOT SCALE THIS DRAWING ON PRINT OR ELECTRONICALLY. WORK FROM FIGURED DIMENSIONS ONLY.
 - NO DEVIATION FROM THE DETAILS ON THIS DRAWING IS ALLOWED WITHOUT CampbellReith's PRIOR PERMISSION IN WRITING.
 - READ THIS DRAWING WITH ALL ARCHITECT'S, SERVICE ENGINEER'S AND CampbellReith's RELEVANT DETAILS AND DRAWINGS. NB. SETTING-OUT DIMENSIONS AS PER THE ARCHITECT'S DRAWINGS TAKE PRECEDENCE.
 - ALL WORK IS TO BE DONE IN ACCORDANCE WITH THE RELEVANT SPECIFICATIONS ISSUED BY CampbellReith, BRITISH STANDARD CODES OF PRACTICE, STATUTORY REQUIREMENTS AND THE CONTRACT DOCUMENTS.
 - DRAWING STATUS:**
P : PRELIMINARY - EVOLVING DRAWINGS FOR APPROVALS, TENDERS, BILLINGS, ETC.
C : CONSTRUCTION - FULLY DEVELOPED DRAWINGS ISSUED UNDER INSTRUCTION FOR CONSTRUCTION
ONLY STATUS C DRAWINGS TO BE USED FOR CONSTRUCTION.
 - SUITABILITY CODE:**
WORK IN PROGRESS:
S0 - WORK IN PROGRESS
SHARED (NON-CONTRACTUAL):
S1 - FOR COORDINATION, **S2** - FOR INFORMATION,
S3 - FOR INTERNAL REVIEW AND COMMENT,
S4 - FOR CONSTRUCTION APPROVAL.
DOCUMENTATION (FOR CONTRACTOR PURPOSES):
D1 - FOR COSTING, **D2** - FOR TENDER, **D3** - FOR CONTRACTOR DESIGN, **D4** - FOR MANUFACTURE / PROCUREMENT.
CONSTRUCTION:
A - FOR CONSTRUCTION, **B** - FOR CONSTRUCTION BUT WITH COMMENTS (i.e. AREAS IN ABEYANCE), **C** - COMPREHENSIVE REVISIONS REQUIRED.

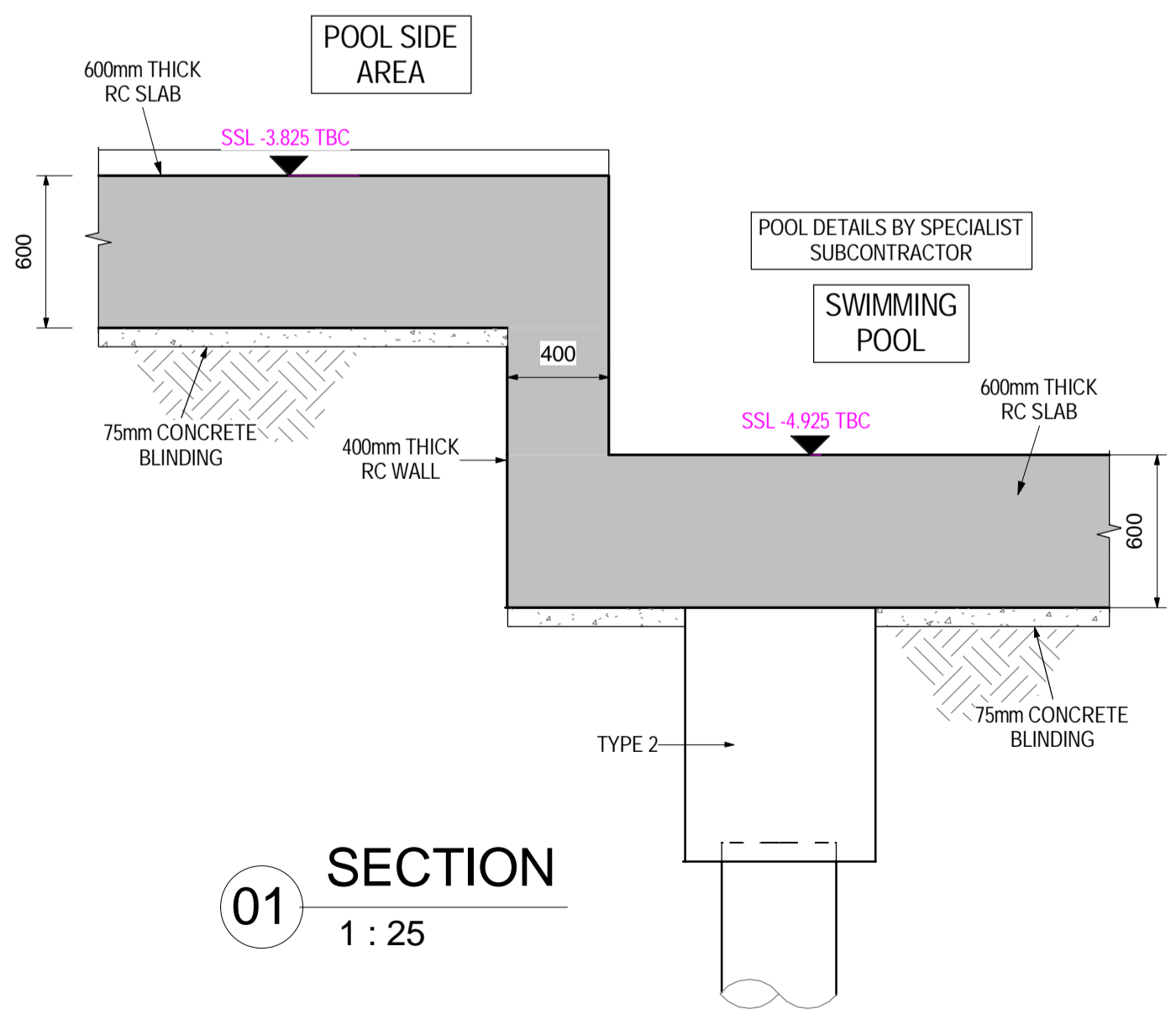

01 SECTION
1 : 25

NOTE: TOP OF SHEET PILES TO HAVE 12mm HOLES INCLUDED TO ENABLE CONNECTION TO RING BEAM WITH 10mmØ REBAR

CampbellReith
consulting engineers

LONDON 020 7340 1700
 SURREY 01737 784 500
 BRISTOL 0117 916 1066

MANCHESTER 0161 819 3060
 BIRMINGHAM 01675 467 484
 DUBAI 00 971 4345 7088

www.campbellreith.com

| Status/Rev | Description | Date | By |
|------------|--|------------|-----|
| P2 | Section ref. revised. Sections to adjoining Building moved to dwg S2301. | 27.06.2016 | NSG |
| P1 | STAGE 3 FOR TENDER | 24.03.2016 | NSG |

Job Title
GREENWOOD CENTRE

Client
KIER

BASEMENT SECTIONS AND DETAILS SHEET 1

| drawn | date | scale @ A1 | C1 checked | CR Project No. | |
|---|---------|------------|------------|--------------------------|---------------------------|
| NSG | MAR '16 | 1 : 25 | | 12291 | |
| Drg No. 12291-CRH-GC-ZZ-DR-S-2300 | | | | Suitability D2 | Status / Rev P2 |

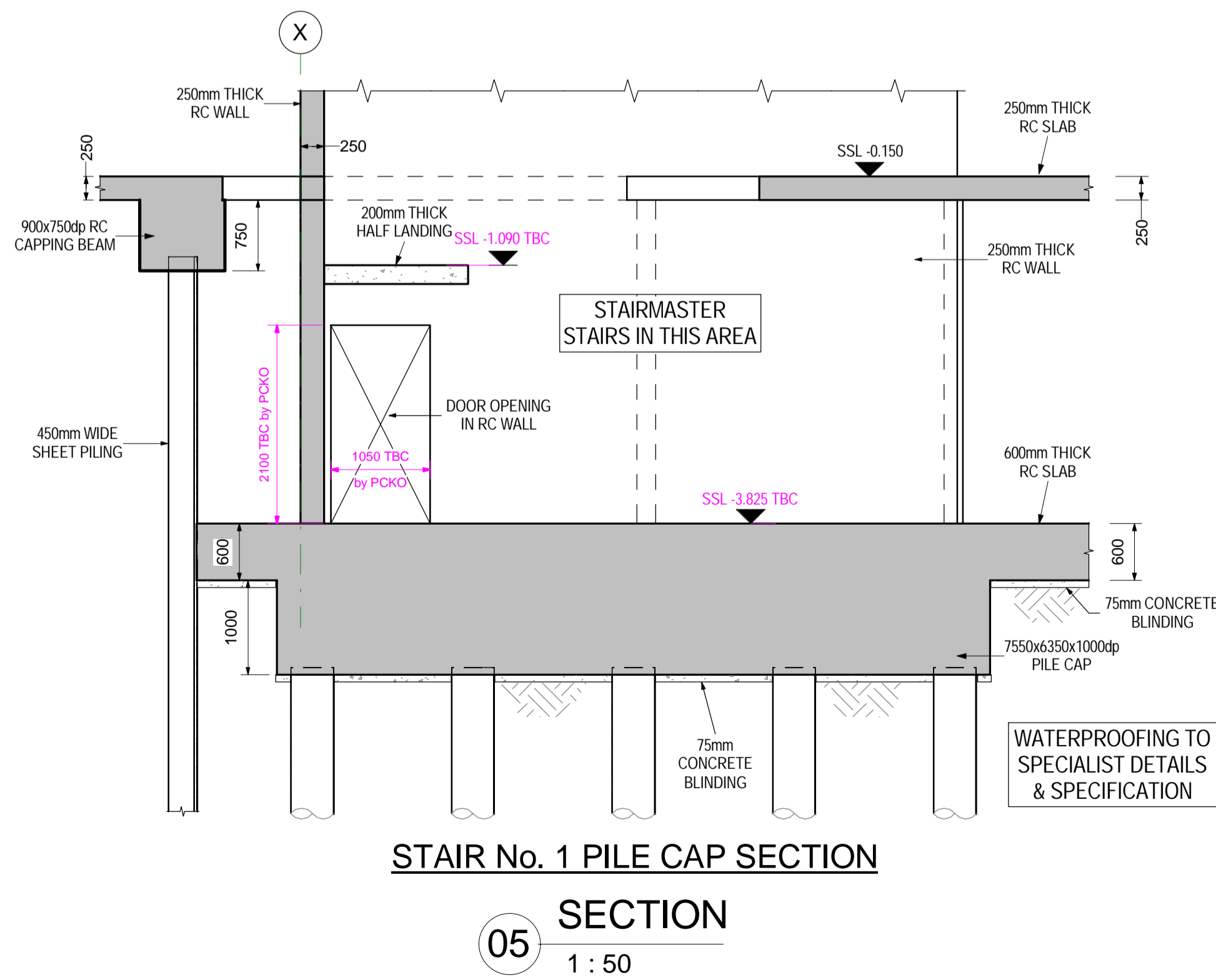
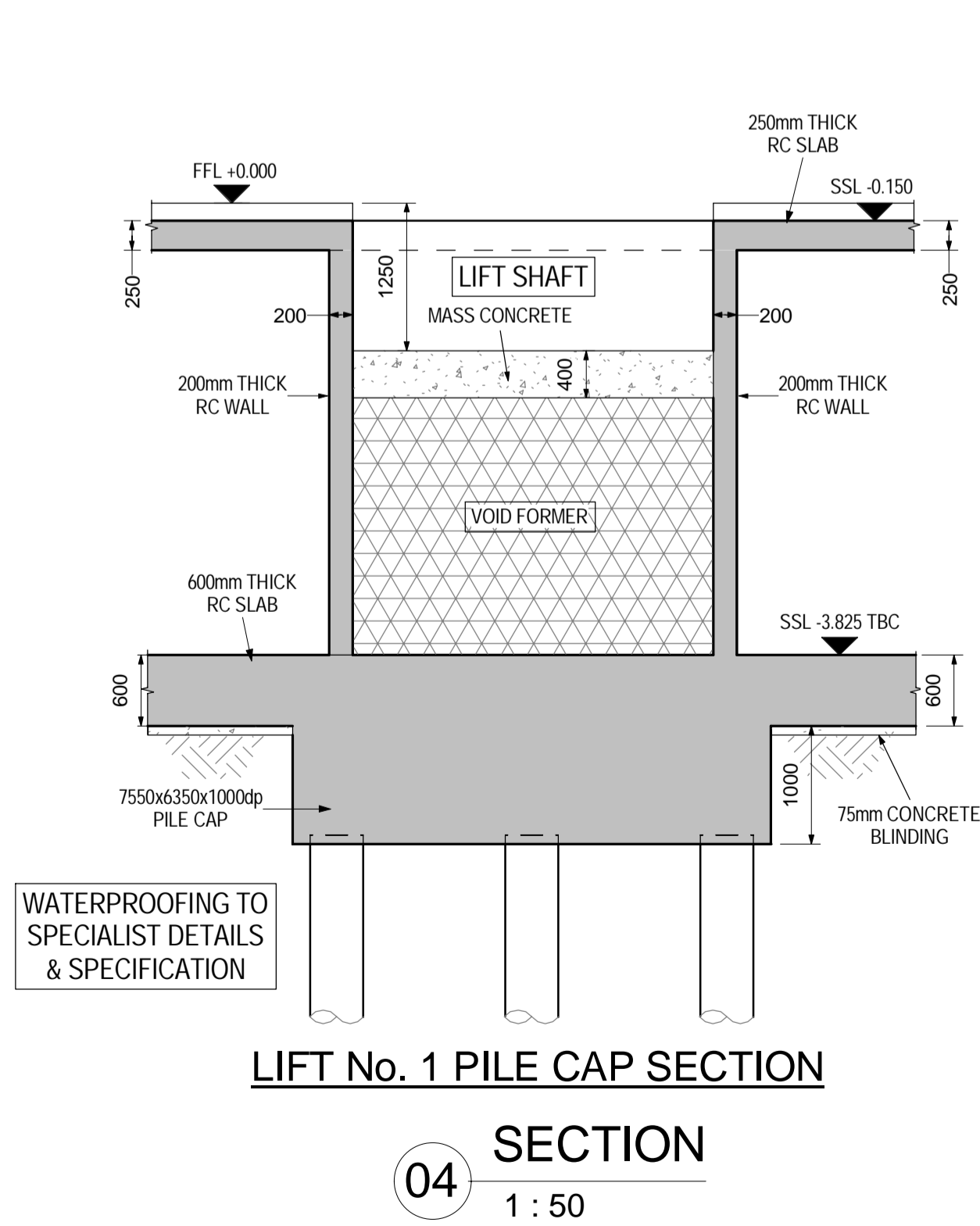
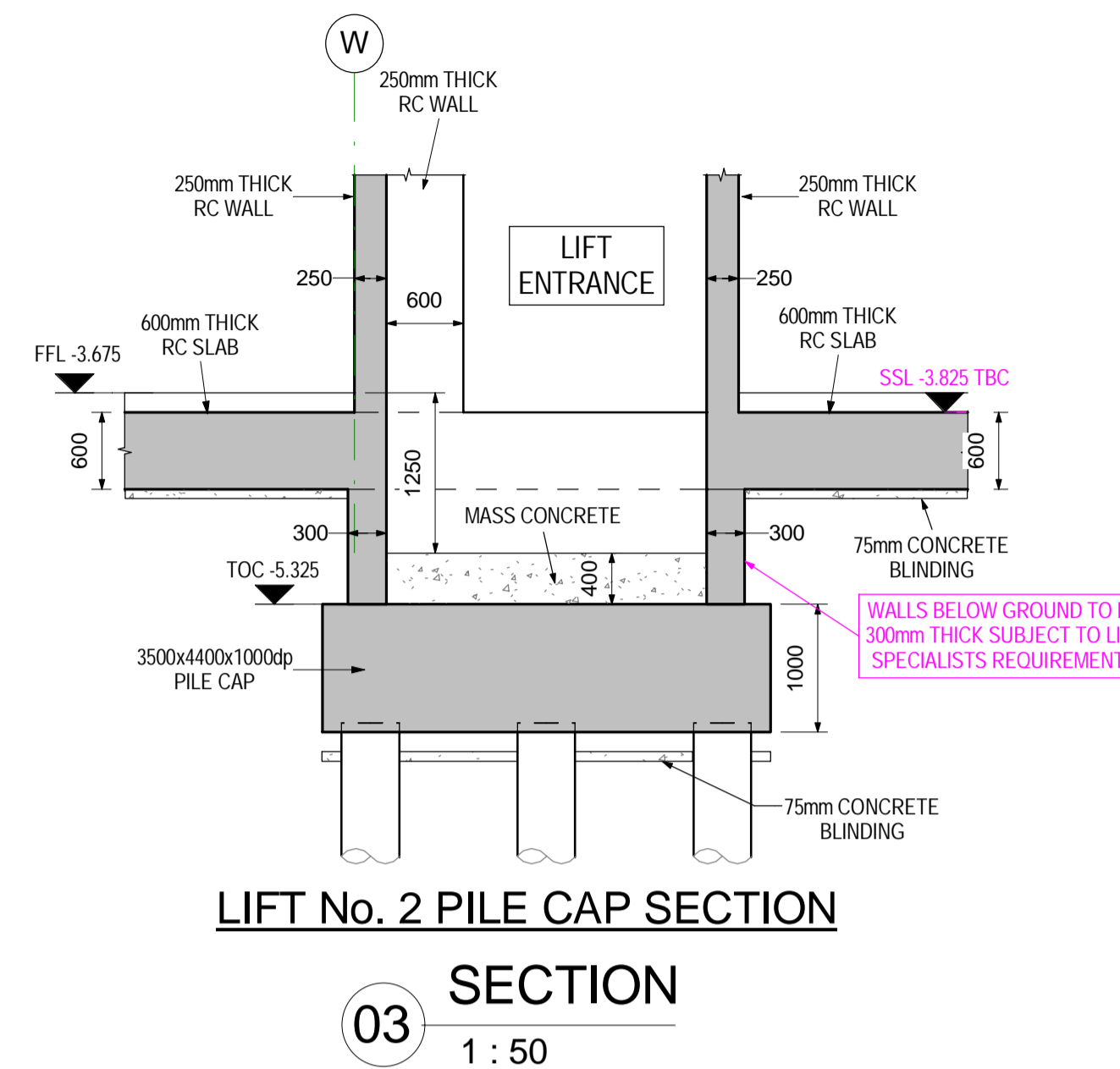
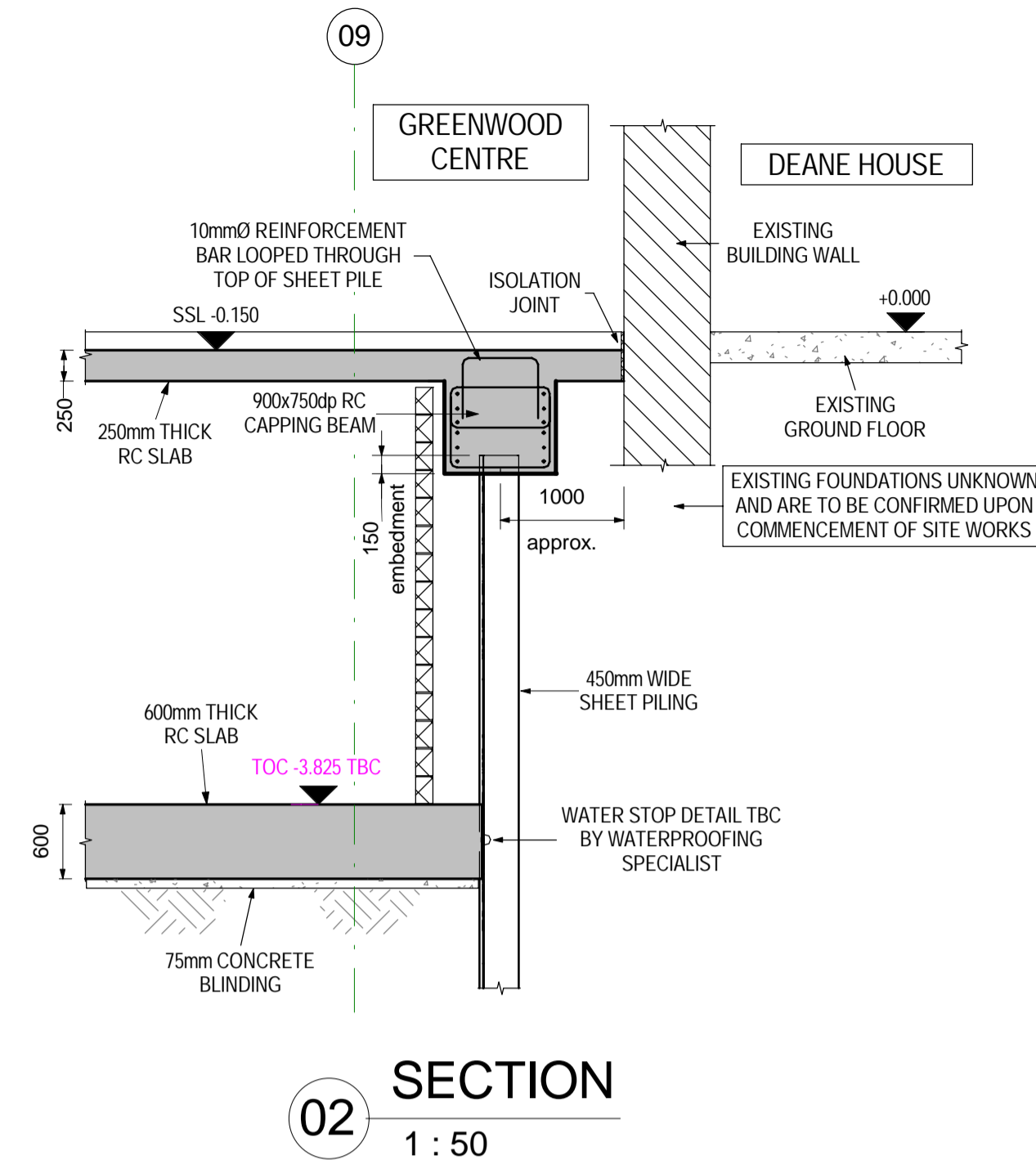
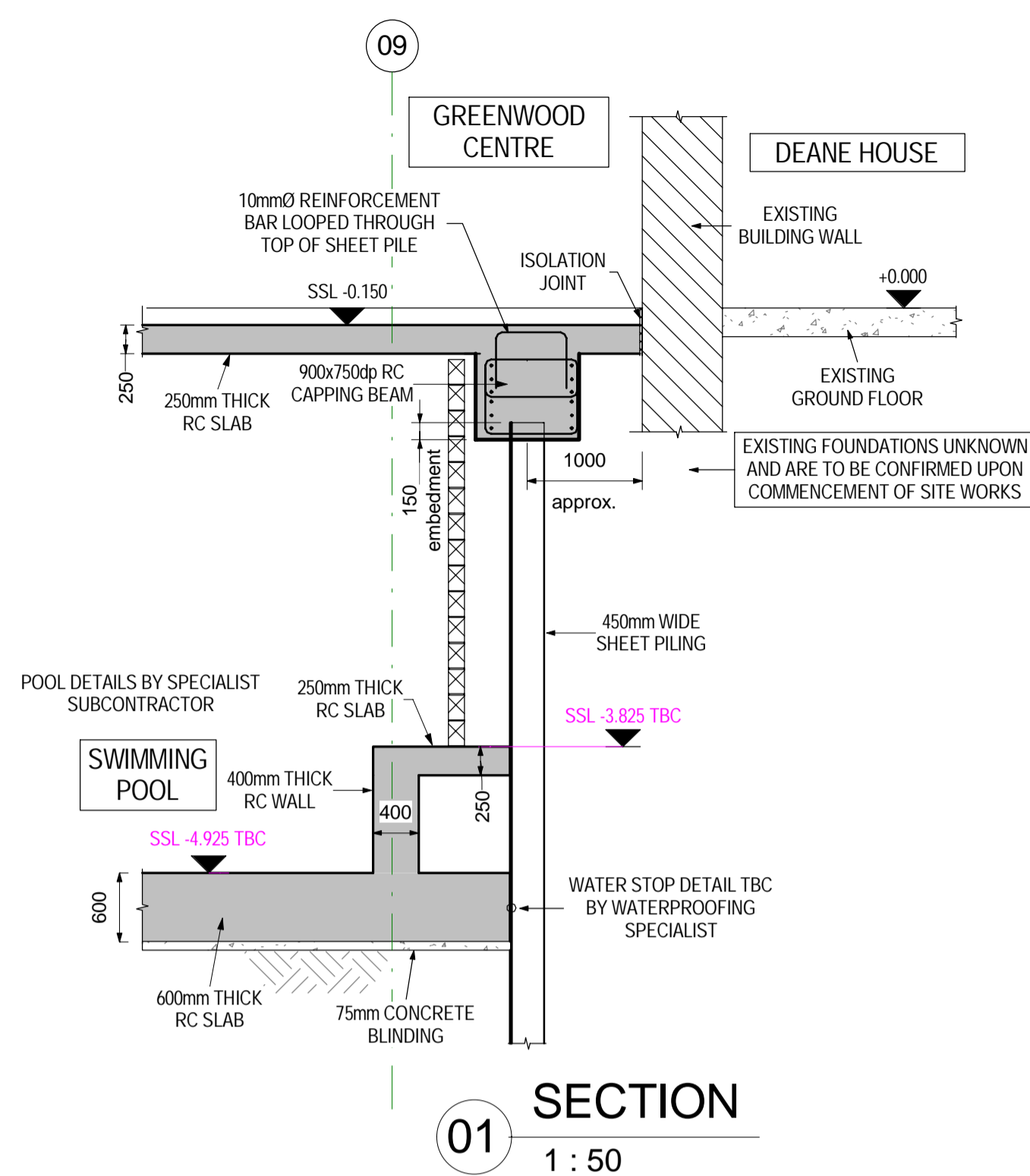

NOTES

- DO NOT SCALE THIS DRAWING ON PRINT OR ELECTRONICALLY. WORK FROM FIGURED DIMENSIONS ONLY.
- NO DEVIATION FROM THE DETAILS ON THIS DRAWING IS ALLOWED WITHOUT CampbellReith's PRIOR PERMISSION IN WRITING.
- READ THIS DRAWING WITH ALL ARCHITECT'S, SERVICE ENGINEER'S AND CampbellReith's RELEVANT DETAILS AND DRAWINGS. NB. SETTING-OUT DIMENSIONS AS PER THE ARCHITECT'S DRAWING TAKE PRECEDENCE.
- ALL WORK IS TO BE DONE IN ACCORDANCE WITH THE RELEVANT SPECIFICATIONS ISSUED BY CampbellReith, BRITISH STANDARD CODES OF PRACTICE, STATUTORY REQUIREMENTS AND THE CONTRACT DOCUMENTS.
- DRAWING STATUS:**
P : PRELIMINARY - EVOLVING DRAWINGS FOR APPROVALS, TENDERS, BILLINGS, ETC.
C : CONSTRUCTION - FULLY DEVELOPED DRAWINGS ISSUED UNDER INSTRUCTION FOR CONSTRUCTION
ONLY STATUS C DRAWINGS TO BE USED FOR CONSTRUCTION.
- SUITABILITY CODE:**
WORK IN PROGRESS:
S0 - WORK IN PROGRESS
SHARED (NON-CONTRACTUAL):
S1 - FOR COORDINATION, **S2** - FOR INFORMATION, **S3** - FOR INTERNAL REVIEW AND COMMENT, **S4** - FOR CONSTRUCTION APPROVAL.
DOCUMENTATION (FOR CONTRACTOR PURPOSES):
D1 - FOR COSTING, **D2** - FOR TENDER, **D3** - FOR CONTRACTOR DESIGN, **D4** - FOR MANUFACTURE / PROCUREMENT.
CONSTRUCTION:
A - FOR CONSTRUCTION, **B** - FOR CONSTRUCTION BUT WITH COMMENTS (i.e. AREAS IN ABEYANCE), **C** - COMPREHENSIVE REVISIONS REQUIRED

| | | | |
|------------|-------------------|------------|-----|
| P1 | ISSUED FOR TENDER | 27.06.2016 | NSG |
| Status/Rev | Description | Date | By |

CampbellReith
consulting engineers

LONDON 020 7340 1700 MANCHESTER 0161 819 3060
 SURREY 01737 784 500 BIRMINGHAM 01675 467 484
 BRISTOL 0117 916 1066 DUBAI 00 971 4345 7088
 www.campbellreith.com

Job Title: **GREENWOOD CENTRE**
 Client: **KIER**

BASEMENT SECTIONS & DETAILS SHEET 2

| | | | | |
|-------|---------|------------|------------|----------------|
| drawn | date | scale @ A1 | C1 checked | CR Project No. |
| NSG | JUN '16 | 1 : 50 | | 12291 |

| | | |
|---------------------------|-------------|--------------|
| Orig No. | Suitability | Status / Rev |
| 12291-CRH-GC-ZZ-DR-S-2301 | D2 | P1 |

NOTE: TOP OF SHEET PILES TO HAVE 12mm HOLES INCLUDED TO ENABLE CONNECTION TO RING BEAM WITH 10mmØ REBAR

Appendix F – Outline Tender Program

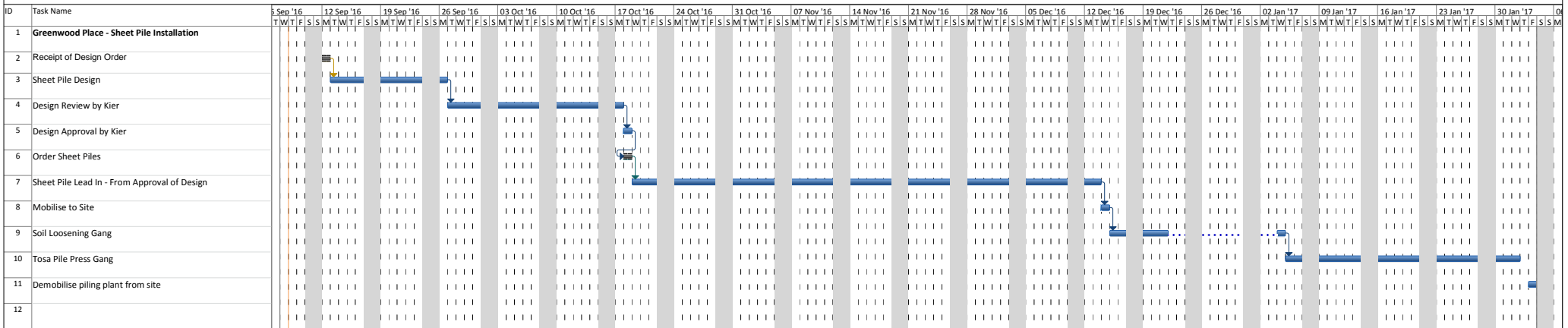

Project: KSP-T0133 Greenwood Place Te
 Date: Thu 08/09/16

| | | | | | | |
|-----------|-----------------|--------------------|------------------|-----------------------|-------------|-----------|
| Task | Summary | External Milestone | Inactive Summary | Manual Summary Rollup | Finish-only | Milestone |
| Split | Project Summary | Inactive Task | Manual Task | Manual Summary | Deadline | Milestone |
| Milestone | External Tasks | Inactive Milestone | Duration-only | Start-only | Progress | Milestone |