

DRAWING TO BE READ IN CONJUNCTION WITH FINISHES SCHEDULE AND DETAIL LOCATION PLAN

DETAILS TO BE CONFIRMED WITH SPECIALIST CONTRACTOR

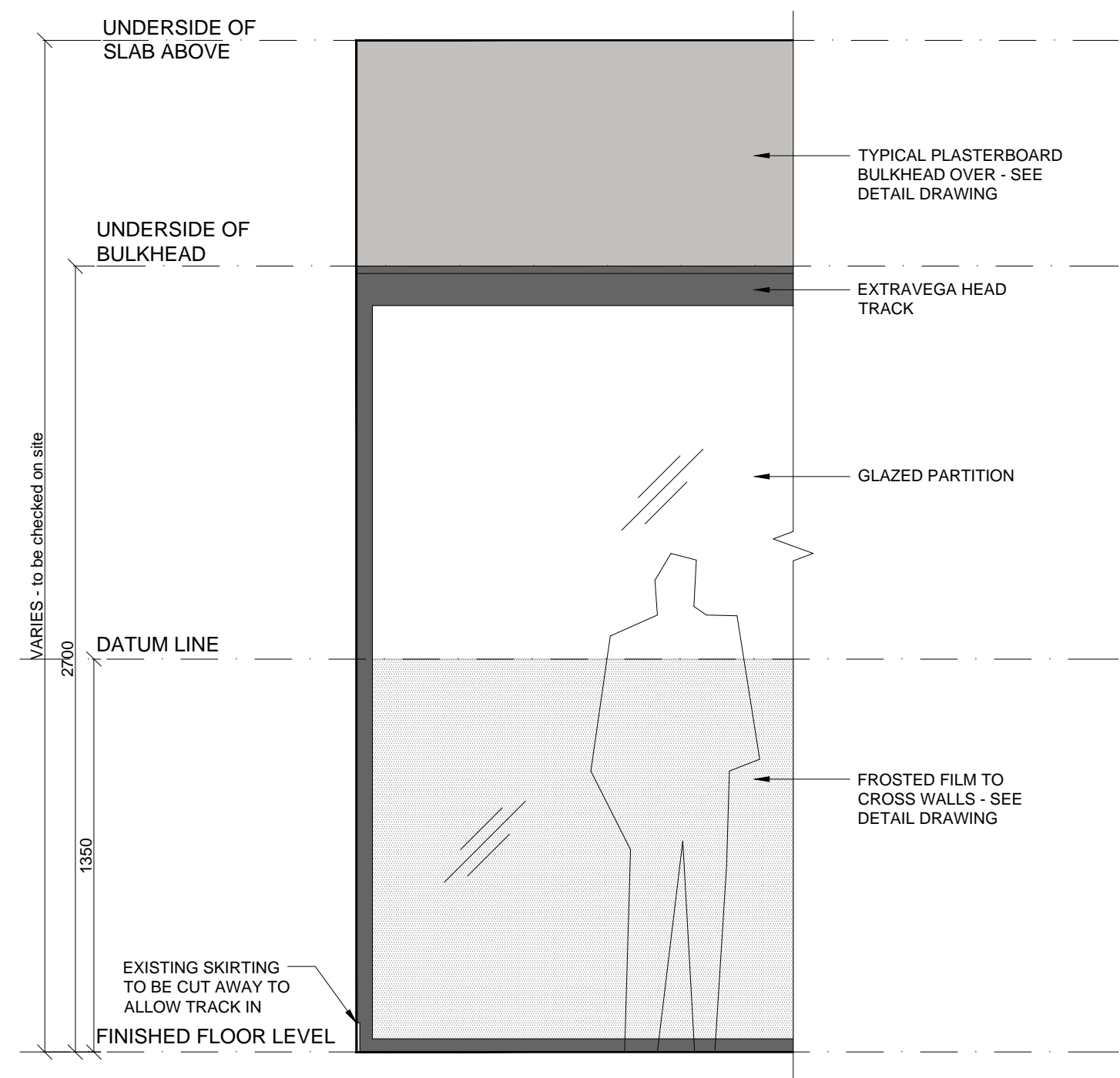

**A** DETAIL A1 - SECTION  
SCALE 1:20

**DETAIL A2 - PLAN SECTION**  
SCALE 1:10

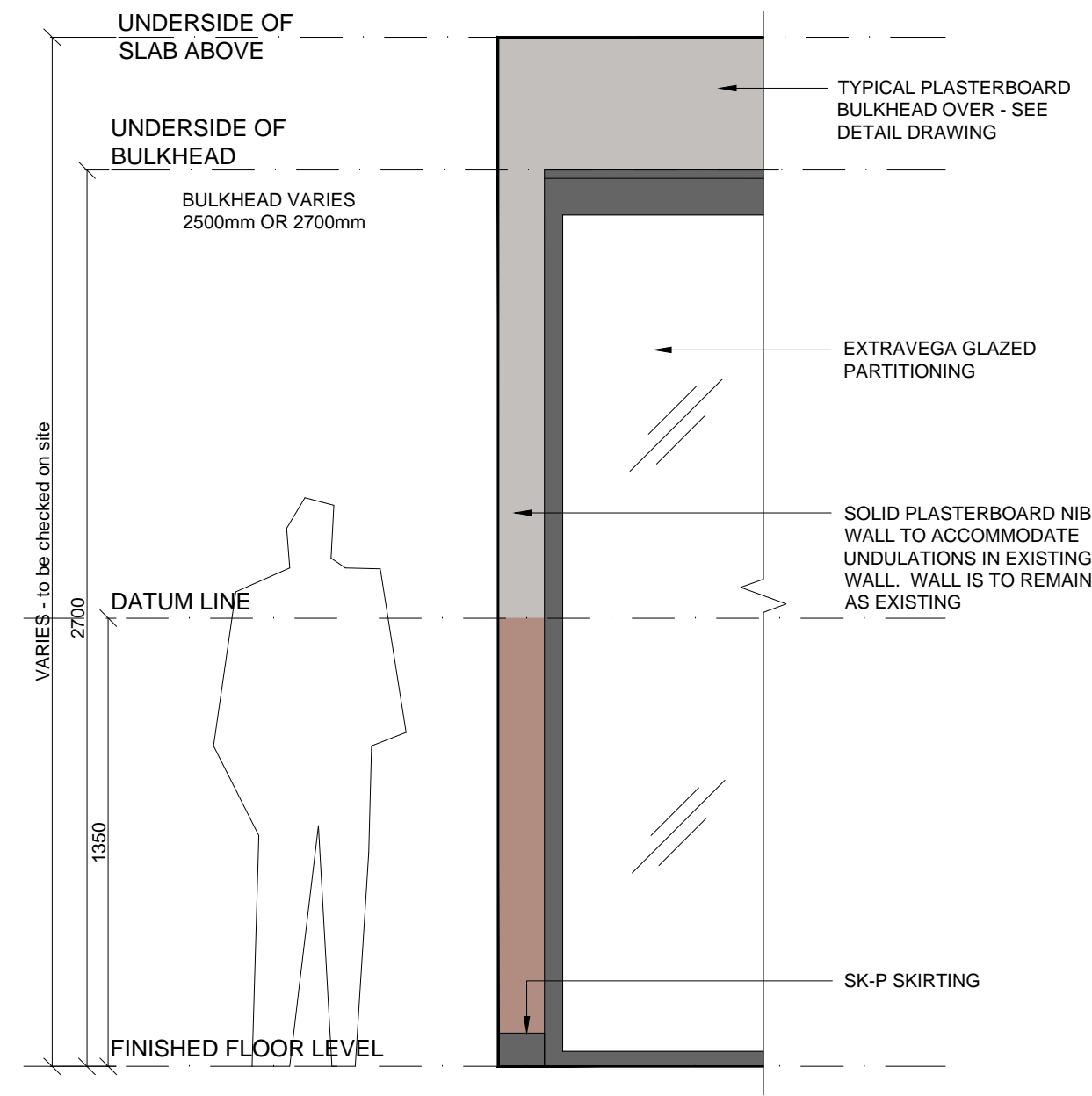
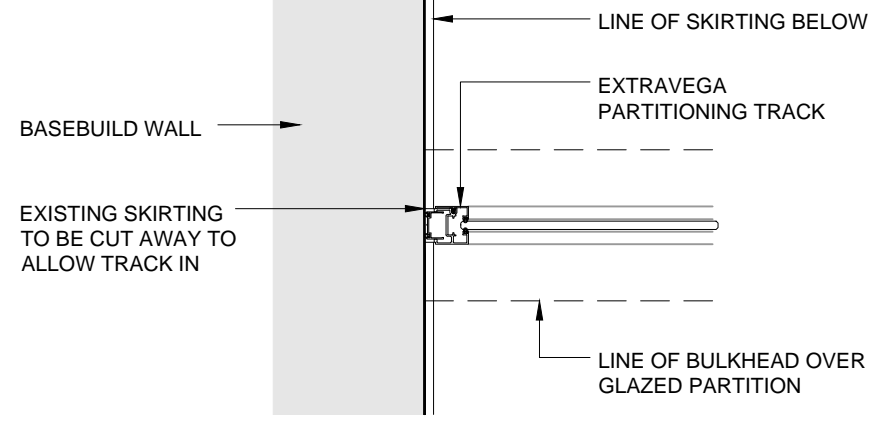

**B** DETAIL B1 - SECTION  
SCALE 1:20

**DETAIL B2 - PLAN SECTION**  
SCALE 1:10

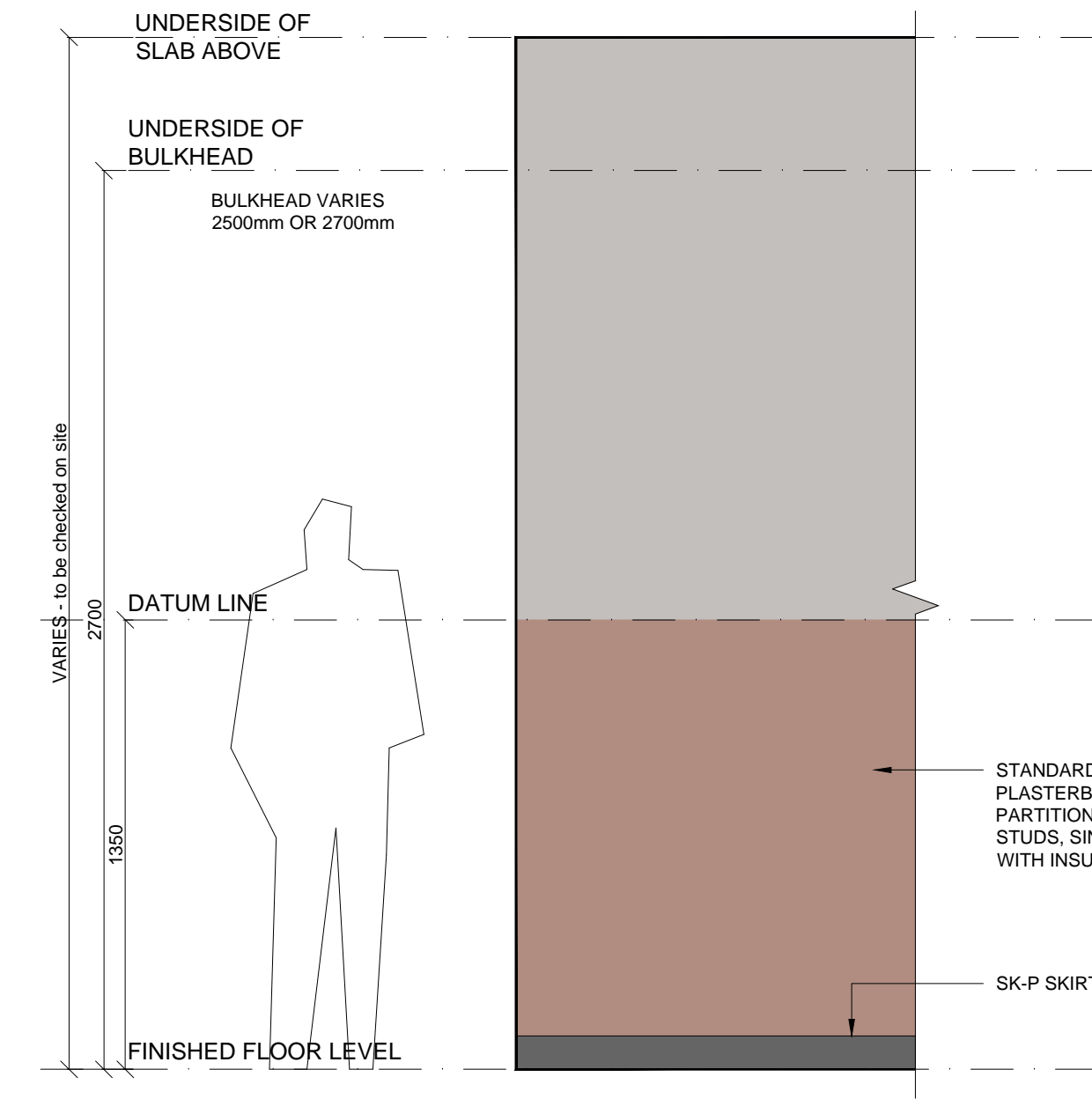
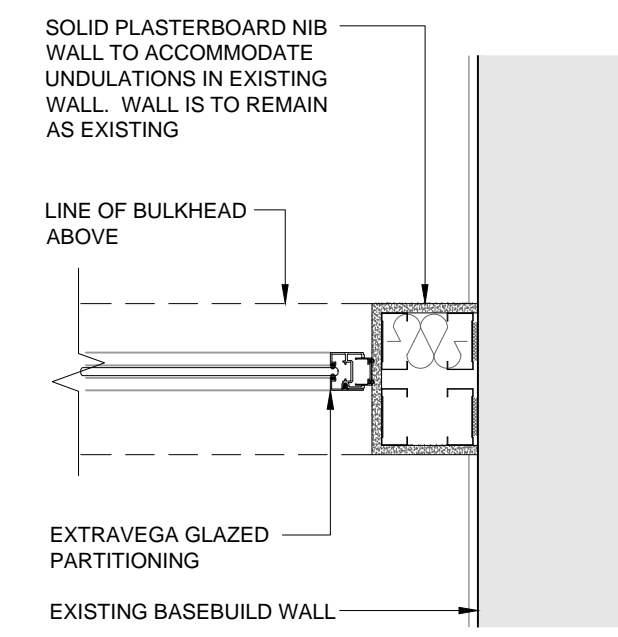

**C** DETAIL C1 - SECTION  
SCALE 1:20

**DETAIL C2 - PLAN SECTION**  
SCALE 1:10

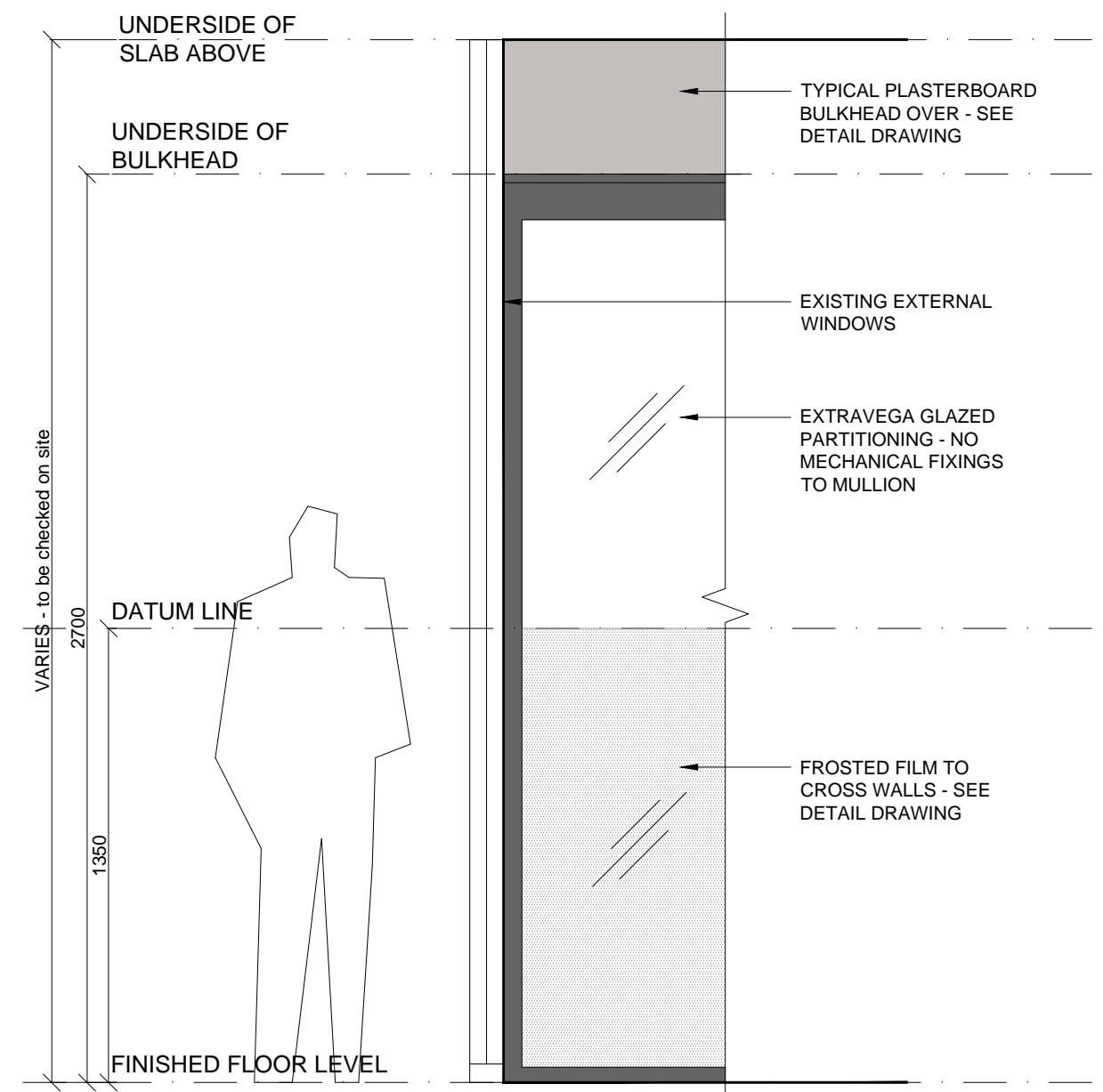
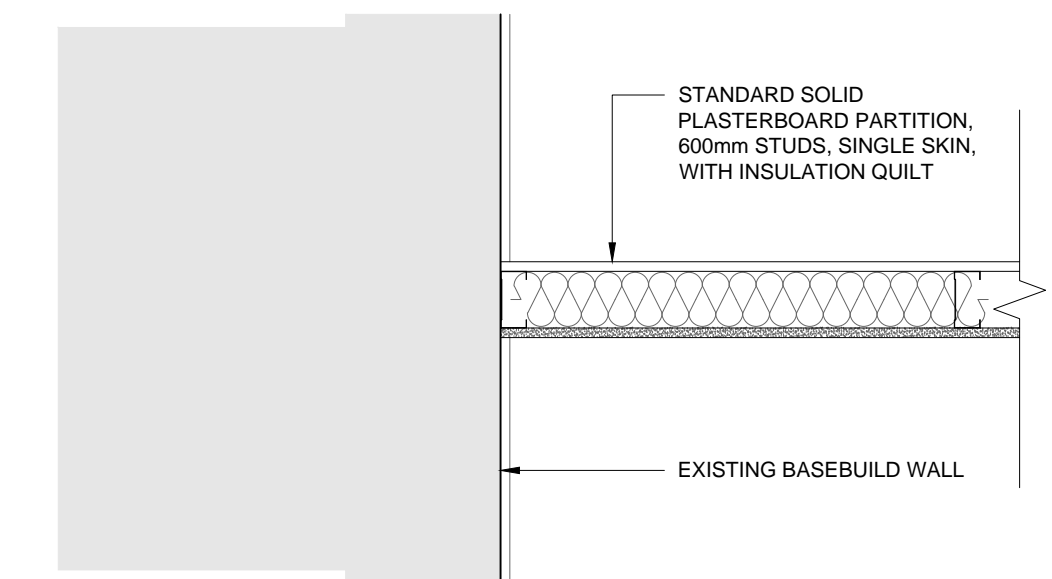

**D** DETAIL D1 - SECTION  
SCALE 1:20

**DETAIL D2 - PLAN SECTION**  
SCALE 1:10

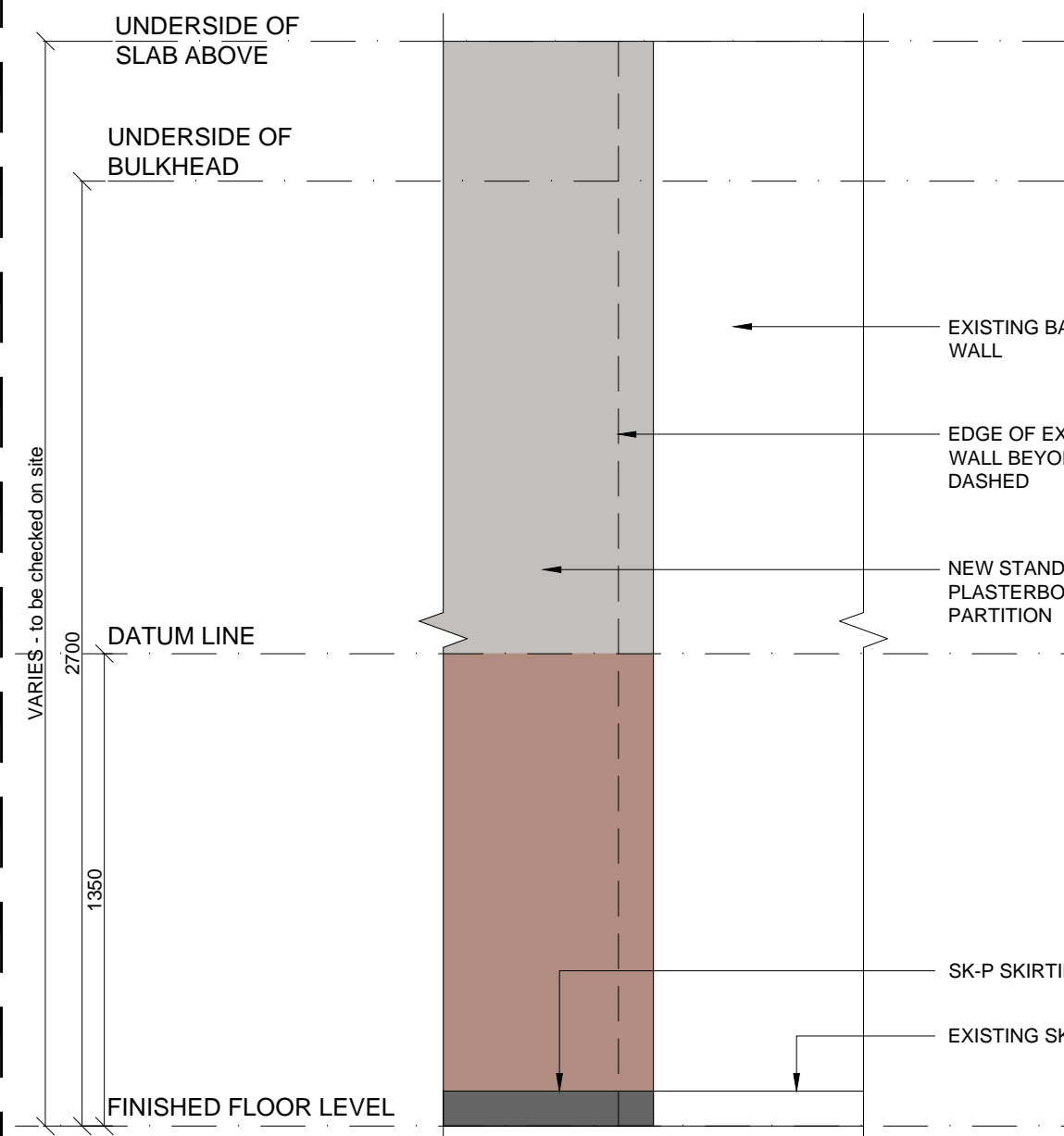
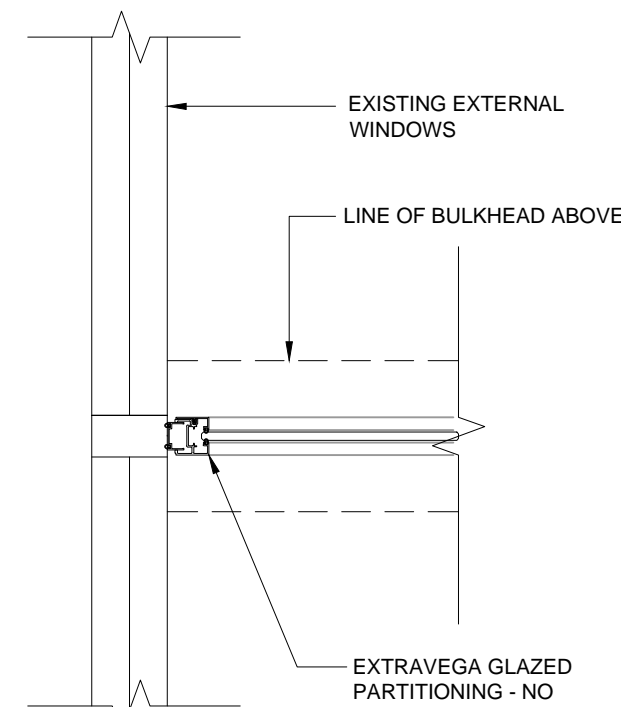

**E** DETAIL E1 - ELEVATION  
SCALE 1:20

**DETAIL E2 - PLAN SECTION**  
SCALE 1:10

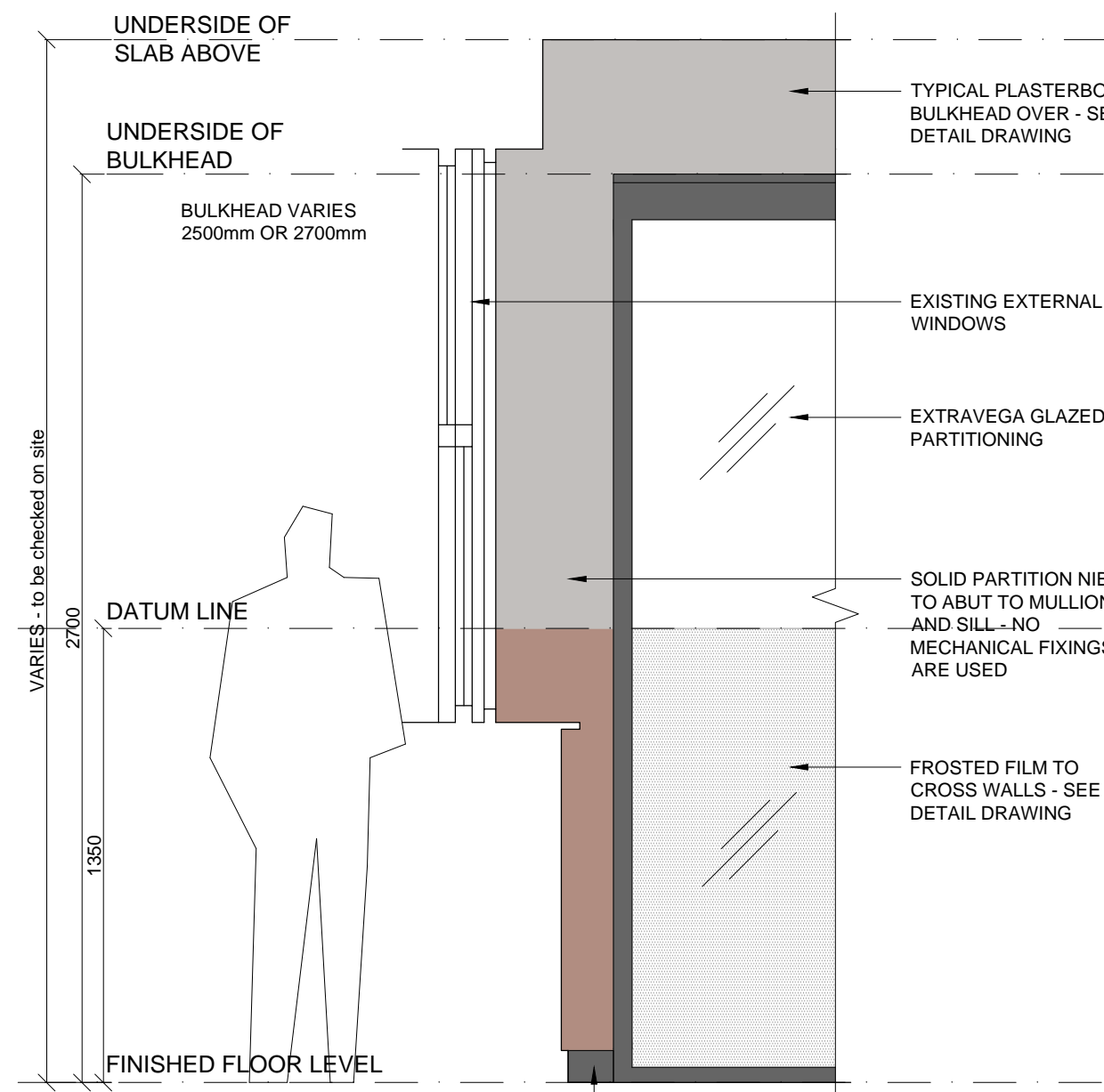
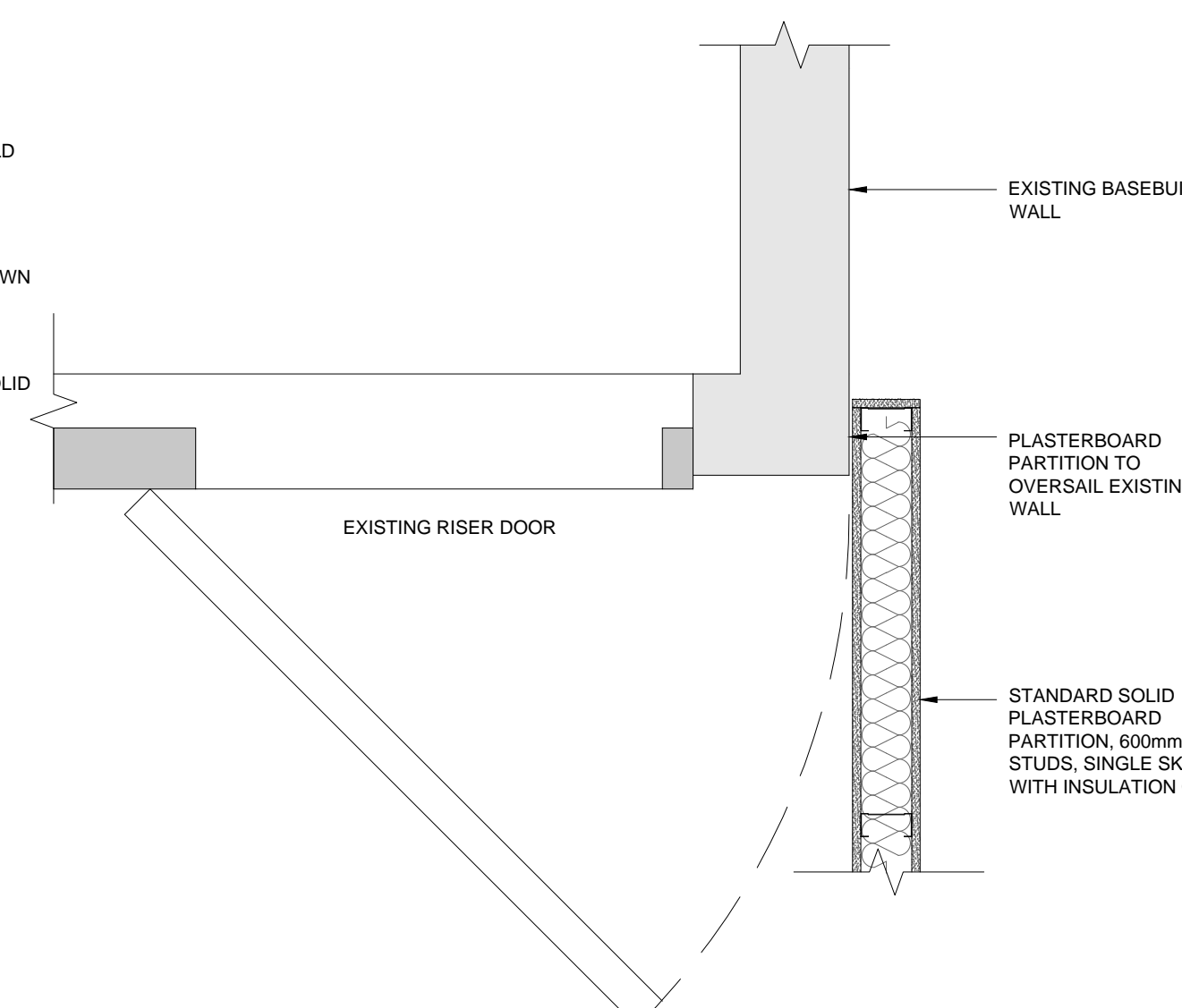

**F** DETAIL F1 - SECTION  
SCALE 1:20

**DETAIL F2 - PLAN SECTION**  
SCALE 1:10

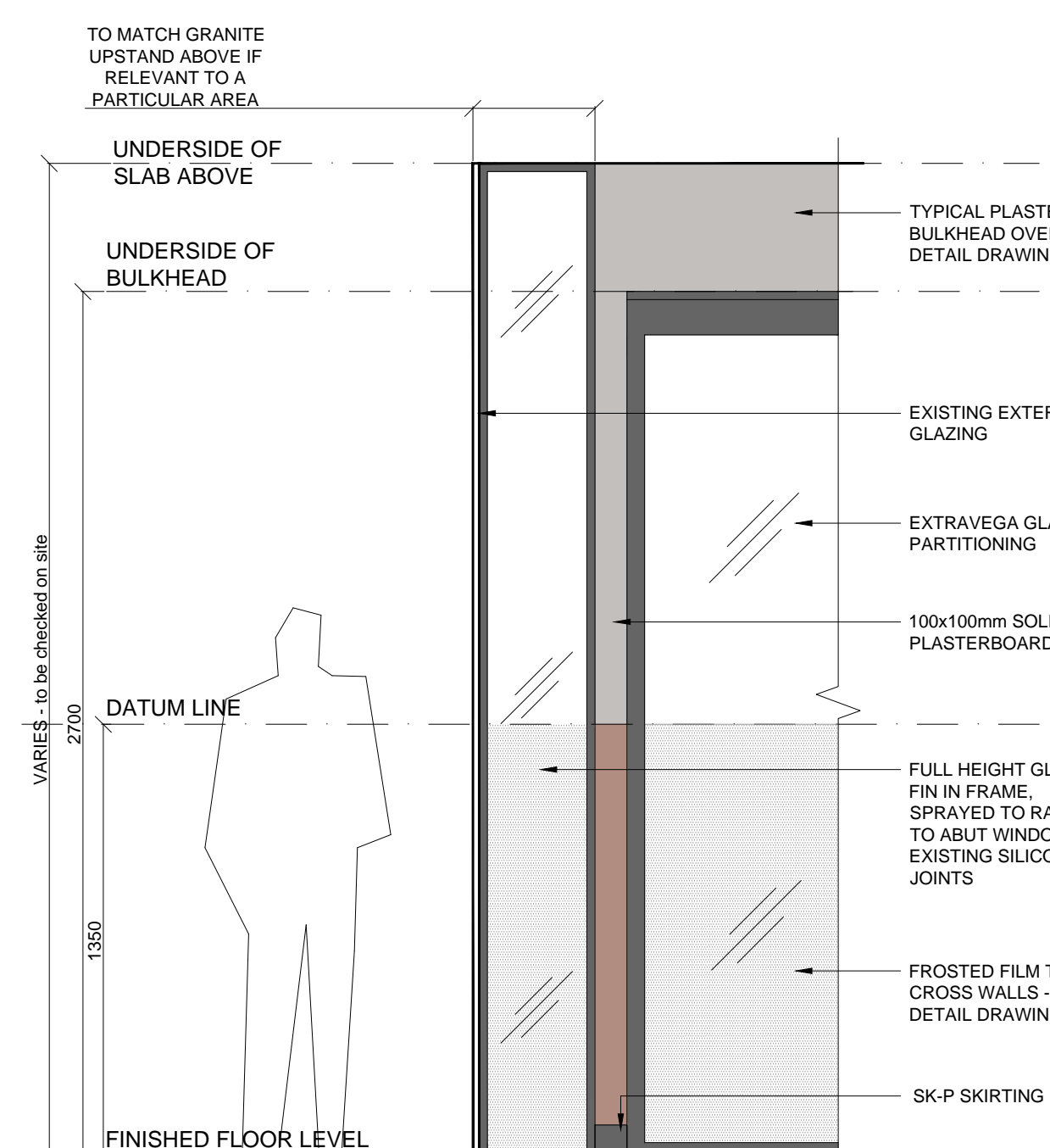
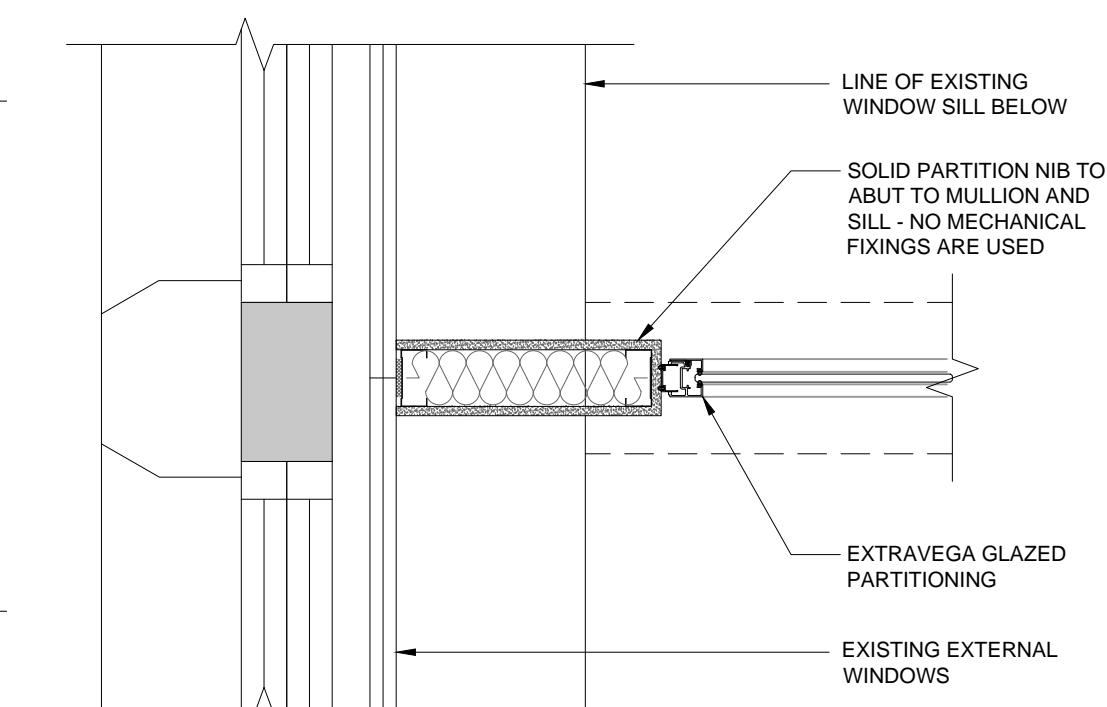

**G** DETAIL G1 - SECTION  
SCALE 1:20

**DETAIL G2 - PLAN SECTION**  
SCALE 1:10

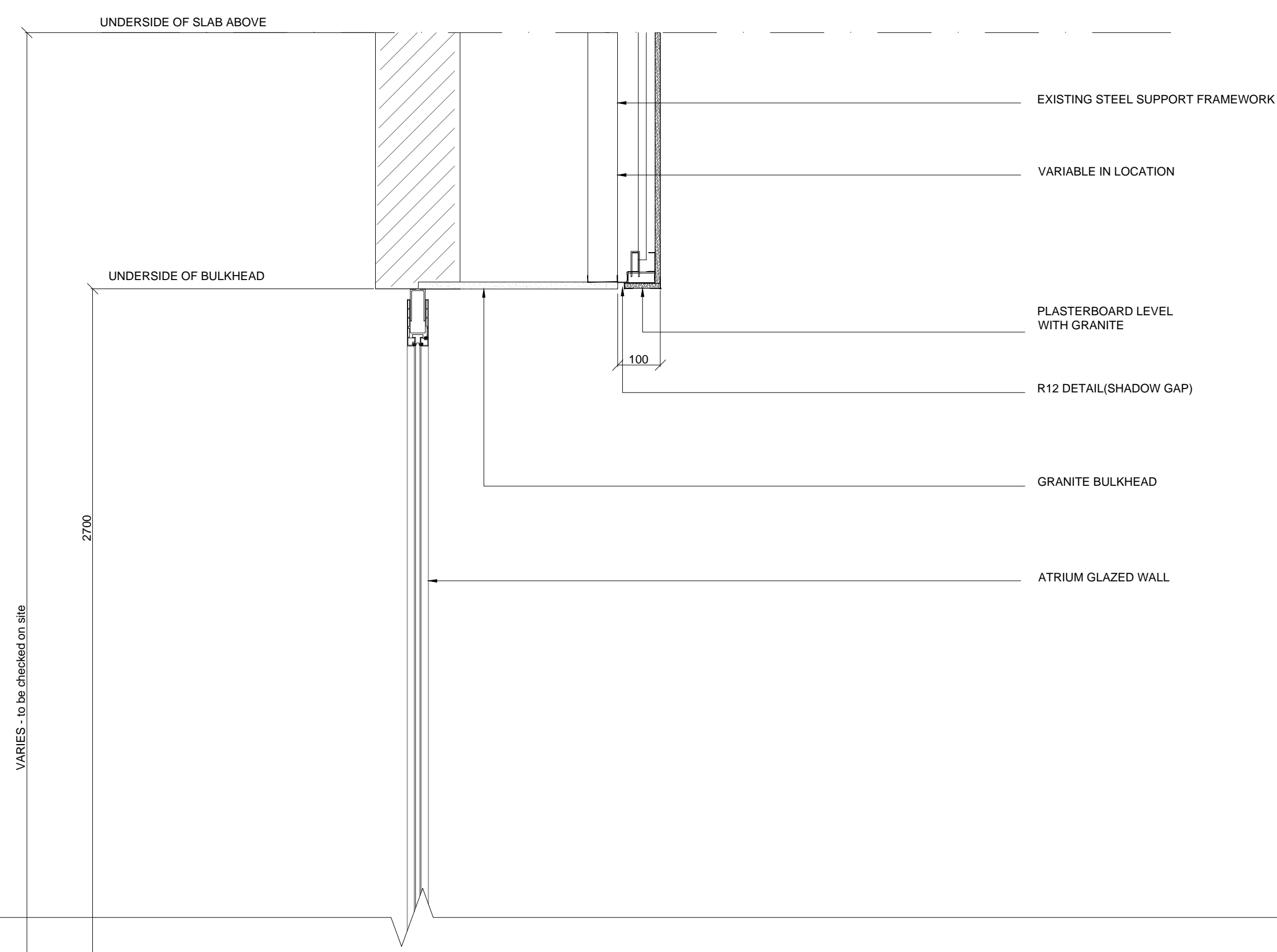
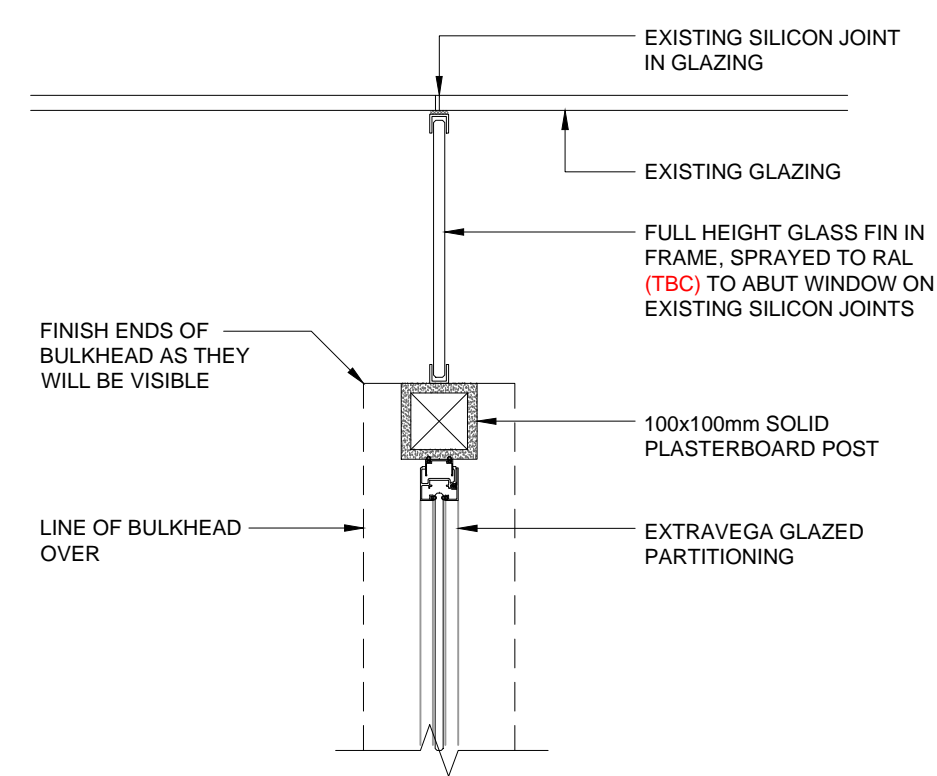

**H** DETAIL H1 - SECTION  
SCALE 1:10

**DRAWINGS TO BE CONFIRMED ONCE SURVEY INFORMATION IS RECEIVED**

NOTES: This drawing is the exclusive Copyright of ltb and may not be copied or handed to any Third parties without prior consent. All dimensions must be checked on site and not scaled from the drawing. All drawings and proposals are subject to approval by statutory authorities.

Rev	Descriptive amendments	Drawn by	Date
-	Drawing first produced	AN	24.06.16
PRE-DESIGN			
Client: <b>WeWork</b>			
Client Contact:			
Site Address: <b>03 Waterhouse Square - PHASE 2</b> Holborn Bars London			
Drawing Title: <b>Typical Abutment Details</b>			
Account Manager: <b>Rob Gregory</b>			
Designer: <b>Senior Tech. Designer / Project Manager</b> <b>Claire Elliott / Glenda Puntel / Martin Leeper</b>			
Scale:	AN	Drawn By:	21/06/2016
Contract Number:	1041	Building:	01
		Floor:	ALL
		Detail:	MS06
		Revision:	/
<b>ltb.</b> 1st floor, 322 High Holborn, London, WC1V 7PB T: +44 (0)20 7553 9500			