

Camden Planning Guidance

Amenity

London Borough of Camden

CPG 6



CPG6 Amenity

1	Introduction	5
2	Air quality	7
3	Contaminated land	15
4	Noise and vibration	19
5	Artificial light	25
6	Daylight and sunlight.....	31
7	Overlooking, privacy and outlook	37
8	Construction management plans	39
9	Access for all.....	45
10	Wind and micro-climate.....	53
11	Open space, outdoor sport and recreation facilities.....	59
12	Planning for healthy communities	79

1 Introduction

What is Camden Planning Guidance?

- 1.1 We have prepared this guidance to support the policies in our Local Development Framework (LDF). It is therefore consistent with the Camden Core Strategy and Development Policies, and is a formal Supplementary Planning Document (SPD) which is an additional “material consideration” in planning decisions. This guidance will replace Camden Planning Guidance 2006, updating advice where appropriate and providing new guidance on matters introduced or strengthened in the LDF.
- 1.2 Camden Planning Guidance covers a range of topics (such as design, housing, sustainability and planning obligations) and all of sections should be read in conjunction with, and within the context of, Camden’s other LDF documents.

Amenity in Camden

- 1.3 A key objective of the Camden Core Strategy is to sustainably manage growth so that it avoids harmful effects on the amenity of existing and future occupiers and to nearby properties.

What does this guidance cover?

- 1.4 This guidance provides information on all types of amenity issues within the borough and includes the following sections:
 1. Air quality
 2. Contaminated land
 3. Noise and vibration
 4. Artificial light
 5. Daylight and sunlight
 6. Overlooking, privacy and outlook
 7. Construction management plans
 8. Access for all
 9. Wind and micro-climate
 10. Open space, outdoor sport and recreation facilities

- 1.5 This guidance supports the following Local Development Framework policies:

Camden Core Strategy

- CS5 - Managing the impact of growth and development
- CS15 - Protecting and improving our parks and open spaces & encouraging biodiversity
- CS16 - Improving Camden’s health and well-being

Camden Development Policies

- DP26 - Managing the impact of development on occupiers and neighbours
- DP28 - Noise and vibration
- DP31 - Provision of, and improvements to, public open space and outdoor sport and recreation facilities
- DP32 - Air quality and Camden's Clear Zones

2 Air quality

KEY MESSAGES:

- All of Camden is a designated Air Quality Management Area due to the high concentrations of nitrogen dioxide (NO₂) and particulate matter (PM₁₀).
- All developments are to limit their impact on local air quality.

2.1 Poor air quality can harm health and the environment. The Council aims to make sure that new development does not harm air quality. This guidance provides advice on how to address air quality issues in planning applications.

2.2 Camden Core Strategy policy CS16 - *Improving Camden's health and well-being* and policy DP32 – *Air quality and Camden's Clear Zone* of the Camden Development Policies sets out our approach to air quality in the borough.

2.3 *Planning Policy Statement PPS23: Planning and Pollution Control* contains the Government's core policies and principles on air quality and air pollution. The London Plan outlines regional policies related to protecting local air quality during the planning process.



Air quality in Camden

2.4 An Air Quality Management Area (AQMA) must be declared by the local authority for an area that is unlikely to meet the national air quality targets for specific air pollutants. The authority then produces a Local Air Quality Action Plan. See Camden's website for our air quality plan.

2.5 The whole of Camden is an Air Quality Management Area (AQMA) as it does not meet national air quality targets for nitrogen dioxide (NO₂) and particulate matter (PM₁₀). The main sources of air pollution in Camden are road transport and gas boilers. The Council's Air Quality Action Plan outlines measures to reduce emissions from the key sources of air pollution in the borough. Included in the plan are measures to minimise and control NO_x and PM₁₀ emissions associated with new developments both during the construction of a building and its future use.

2.6 Air quality is particularly poor in the south of borough which is characterised by high levels of traffic. We will only grant planning permission for development that significantly increases travel demand in

the south of the borough where it includes appropriate measures to minimise the transport impact of development.

- 2.7 Where appropriate we will seek developments to include monitoring equipment to allow us to better understand local air quality.

WHAT DOES THE COUNCIL REQUIRE?

The Council's overarching aim is for new development is to be 'air quality neutral' and not lead to further deterioration of existing poor air quality.

You will be required to include mitigation and offsetting measures to deal with any negative air quality impacts associated with your development proposals. At the same time your development should be designed to minimise exposure of occupants to existing poor air quality.

To manage and prevent further deterioration of air quality in Camden, we will require an air quality assessment with planning applications for development that could have a significant negative impact in air quality. This impact can arise during both the construction and operational stages of a development as a result of increased NO_x and PM₁₀ emissions.

- 2.8 An air quality assessment will also be required for a proposal if it introduces uses that are susceptible to poor air quality, such as housing or a school, into areas of particularly poor air quality.
- 2.9 The Council will not grant planning permission for developments that could significantly harm air quality or introduce people into areas of elevated pollution concentrations, unless mitigation measures are adopted to reduce the impact to acceptable levels and protect public exposure (see paragraph 32.4 of policy DP32 of the Camden Development Policies).
- 2.10 Although all of Camden is covered by an AQMA we will only require an air quality assessments where development could potentially cause significant harm to air quality as set out in the table below.

An Air Quality Assessment is required in developments:

- with potential to significantly change road traffic on any road exceeding 10,000 vehicles per day. Significant changes include:
 - increase in traffic volumes > 5% (Annual Average Daily Traffic (AADT) – or peak);
 - lower average vehicle speed or significant increase in congestion;
 - significant increase in the percentage of HGVs;
- that introduce, or increase car parking facilities by, 100 spaces or more;
- with commercial floorspace of more than 1,000sq m;
- with more than 75 homes;
- where people will be exposed to poor air quality for significant periods of the day, in particular developments located on busy roads;
- involving the following - biomass boilers, biomass or gas combined heat and power (CHP);
- involving industrial or commercial floorspace regulation under the Environmental Permitting (England and Wales) Regulations (EPR) which will be subject to Environmental Assessment under the Town and Country Planning (Environmental Impact Assessment) Regulations 1999.

What should an air quality assessment cover?

- 2.11 Air quality assessments for developments potentially contributing to poor air quality are to include the following:
- a) An inventory of the PM₁₀ and NO_x emissions associated with the proposed development, including the type and quantity of emission concentrations, during the construction and operational phase. This shall cover transport, stationary and mobile emission sources.
 - b) The application of atmospheric dispersion modelling to predicted existing and future NO₂ and PM₁₀ concentrations, both with and without the proposed development. Dispersion modelling shall be carried out in accordance with Air Quality and Planning Guidance, London Councils (2007) and Technical Guidance Note (TG09). (Specific guidance for modelling combustion plant emissions can be obtained from the Council's Sustainability Team – see Useful Contacts at the end of this section).
 - c) An assessment of the significance of air quality impacts during both the construction and operational phases. Reference shall be made to the Environmental Protection UK Guidance Note: Development Control: Planning for Air Quality (2010 Update).
 - d) Consideration of the potential cumulative impacts on air quality which may arise during the construction or operational phases as a result of emissions arising from other developments within a 100m radius of the development.
 - e) Where a biomass boiler or combined heat and power (CHP)/combined cooling, heating and power (CCHP) will be used for

on site energy generation, you are to complete the Council's Air Quality Information Request Form. This requires specific technical details related to the appliance, fuel type, emission concentrations, maintenance and exhaust stack. The forms can be obtained from Camden's Air Quality Officer or the Council's air quality webpage under Environment.

- f) Applications which include biomass boilers or biomass CHP, the air quality assessment shall compare the impact of emissions from the intended biomass boiler/CHP and a gas boiler/CHP of identical thermal rating.
- g) An indication of the number of new occupiers and users of the site who will be exposed to poor air quality as a result of the development (the occupiers/users should also be shown on a map). For further information please refer to the Environmental Protection UK Guidance Note: Development Control: Planning For Air Quality (2010 Update).
- h) An assessment of the impacts on air quality of the demolition and construction phase and details of mitigation methods for controlling dust and emissions from plant and machinery. Reference should be made to the Best Practice Guidance: The control of dust and emissions at construction and demolition, London Councils (2006).
- i) An outline of, and justification for, mitigation measures associated with the design, location and operation of the development in order to reduce air pollution and exposure to poor air quality.

Developments containing sensitive uses

- 2.12 Developments which will not result in additional NO_x and/or PM₁₀ emissions and present no risk in worsening air quality, but introduce new sensitive uses to an area which breaches the air quality standards for NO₂ or PM₁₀ need to submit an assessment of the local air quality but can omit requirements B, D and E above.

What measures can reduce air pollution emissions and protect public exposure?

- 2.13 Various actions can be taken to mitigate air pollution emissions arising from the construction and operational phases of a new development. Additional actions can be adopted to curtail public exposure in areas where air pollution levels are particularly high. These should be taken into account during the design stage of an application. The key measures are detailed below:

Demolition and construction

- 2.14 The impact of the construction and demolition phases of a development on air quality must be taken into account as part of your planning application. Exhaust



emissions from construction vehicles and machinery such as generators, piling and grinding equipment can result in:

- dust emissions;
- gases (NO_x); and
- fine particles.

2.15 Controlling dust emissions is important to:

- prevent disturbance to local residents due to soiling;
- minimise damage to vegetation; and
- reduce impacts on local PM₁₀ concentrations, thereby protecting public health.

2.16 We may require PM₁₀ monitoring, before and during the construction and demolition phase, dependant upon the scale of the proposed development.

2.17 We will encourage best practice measures to be adopted during construction and demolition work to reduce and mitigate air pollution emissions. You will be encouraged to adopt the procedures outlined in the London Council's best practice guidance *The control of dust and emissions from construction and demolition*. These focus around three principles to control emissions – prevention, suppression and containment. We will expect you to include the following items in construction management plans:

- Identification of whether demolition/construction represents a low, medium or high risk site in the context of air quality.
- Identification of the best practice measure required to control and mitigate plant and vehicles exhaust emissions.
(See section 8 of this Guidance on Construction management plans for further details).

Distance of impacts

Depending of the size, location and characteristics of your development, impacts from demolition and construction phases can occur at distance of 10 to 500m.

Building location and design

2.18 The location of a development has a direct influence on exposure to elevated air pollution levels. This is particular relevant where developments include sensitive uses such as hospitals, schools and children's playgrounds. Suitable building design, layout and orientation can avoid increasing exposure whilst minimising energy demand and energy loss. The Council requires the impact of outdoor air pollution on indoor air quality in new developments to be taken into account at the earliest stages of building design.

- 2.19 The location of outside space is also an important consideration and any exposure of gardens and roof terraces should be screened and, where practicable, minimised through appropriate positioning and orientation. You should take care not to locate flues and exhaust vents in close proximity to recreational areas such as roof terraces or gardens. An energy efficient building design can minimise air pollution resulting from the use of gas boilers. Adopting sustainable building design (e.g. the Code for Sustainable Homes and the Building Research Establishment Environmental Assessment Method (BREEAM)), will reduce thermal heat losses and result in less gas use leading to lower NO_x emissions. See Camden Planning Guidance 3 – Sustainability for further details on the Code and BREEAM.

Gas boilers

- 2.20 Gas boilers are a large source of NO_x emissions in Camden. In order to minimise NO_x emissions arising from heating and hot water systems the Council requires boilers fitted in new development to achieve a NO_x emissions of <40 mg/m³ and an energy efficiency rating >90%.

Renewable Energy and Combined Heat and Power

- 2.21 Core Strategy policy CS13 promotes the use of renewable energy technologies to reduce carbon emissions and tackle climate change. The adoption of renewable energy and energy efficiency technologies in major developments can minimise air pollution emissions through reductions in gas consumption required for heating and hot water. These include solar thermal collectors and ground source heat pumps in addition to gas and hydrogen fuel cell combined heat and power (CHP) or combined cooling heat and power (CCHP).

Hydrogen fuel cell

A fuel cell is an electrochemical cell that converts energy from a fuel (hydrogen) into electricity.

- 2.22 Biomass boilers however can give rise to higher emissions of NO_x and PM₁₀ emissions than conventional gas boilers. Permission to operate these appliances will only be granted if the air quality impacts are demonstrated to be equivalent or lower than those associated with a conventional gas boiler of similar thermal rating. Where an assessment demonstrates adverse effects on air quality, this type of biomass boiler should not be used in the development.
- 2.23 You are advised to refer to the national guidance note *Biomass and Air Quality Guidance Note for Local Authorities*, published by Environmental Protection UK. In cases where emissions released from a biomass boiler do not lead to negative impacts on air quality, the



appliance will be required to meet high standards of air pollution control with particular emphasis given to:

- boiler design and operation;
- pollution abatement equipment;
- servicing and maintenance;
- fuel quality, storage and delivery; and
- exhaust stack height.

2.24 We will require evidence that the exhaust stack height of gas CHP/CCHP has been appropriately calculated to guarantee that NO_x emissions are effectively dispersed, and do not risk increasing ground level NO₂ concentrations. An air quality assessment will be required for developments including CHP/CCHP. Where the assessment reveals a negative impact on air quality, mitigation measures will be required entailing the best available techniques to reduce emissions. This includes the installation of NO_x abatement technology such as:

- use of low NO_x burners; or
- increasing stack height.

2.25 A programme of on-going maintenance and servicing will be necessary to minimise gas emissions released from CHP/CCHP.

2.26 The Council will use Section 106 obligations to set requirements for controlling emissions from biomass boilers and CHP/CCHP.

Traffic Reduction

2.27 Reducing car usage caused by new developments is the principle way to minimise vehicle emissions and protect local air quality. Please refer to transport policy *CS11 - Promoting sustainable and efficient travel* in the Camden Core Strategy for more on our approach to improving air quality through transport measures. This requires:

- the adoption of car free and car capped developments;
- provision cycling facilities to encourage sustainable transport;
- green travel plans;
- provision of car club bays; and
- infrastructure for low emissions vehicles such as electric vehicle recharging points.

Further information

Planning Guidance	<ul style="list-style-type: none"> • Planning Policy Statement 23: Planning and Pollution Control (2004) • Planning Policy Statement 23 Annex 1: Pollution Control, Air and Water Quality These documents outline the government's advice on methods of planning for pollution control.
Air Quality Guidance	<ul style="list-style-type: none"> • Technical Guidance Note: Assessment of Air Quality Issues of Planning Applications, Association of London Government (ALG), 2006 This provides technical advice on how to deal with planning applications that could have an impact on air quality. • Development Control: Planning for Air Quality. Environmental Protection UK, 2010 This advises of the significance of air quality assessments within the planning process. • Best Practice Guidance - The control of dust and emissions from construction and demolition (London Councils) 2006 The aim of this guidance is to protect the health of on-site workers and the public and to provide London-wide consistency for developers. • Biomass and Air Quality Guidance for Local Authorities (Environmental Protection UK) 2009 This guidance details procedures for assessing and managing the effects of biomass on air quality and provides background material. • Low Emission Strategies (Beacon Low Emission Group) 2009 This provides advice on how to reduce emissions of air pollutants and greenhouse gases from transport.
Useful Contacts	<p>Camden Council Corporate Sustainability Team www.camden.gov.uk/smallsteps (020 7974 4444) provides guidance on air quality in Camden</p>

3 Contaminated land

KEY MESSAGES:

- Contaminated land can pose a serious risk to health.
- The Council will expect developers to identify and assess potentially contaminated land at an early stage.
- Developers will be expected to follow the Council's Contaminated Land Strategy.

3.1 This guidance provides advice on how to approach the development of potentially contaminated sites. This guidance should be read in conjunction with Core Strategy policy CS16 – *Improving Camden's health and well-being*.

3.2 To protect the local environment and the health and well-being of residents, workers and visitors, we will carefully assess any proposals for the redevelopment of sites that:

- are known to be contaminated;
- have the potential to be contaminated, through previous or current uses; or
- are located in close proximity to these sites.

What is contaminated land?

3.3 Contaminated land is land that has been polluted with harmful substances to the point where it now poses a serious risk to health and the environment.

Causes of land contamination

- improper chemical handling or disposal practices,
- accidental spillages, or leakages of chemicals during manufacturing or storage.
- polluted groundwater migrating under a site
- particles settling from factory emissions.

3.4 The most common pollutants of land are metals and organic compounds. Typical land uses that can cause land contamination include petrol stations and gas works.

3.5 Contamination can also come from historical activities dating back many hundreds of years, such as spoil heaps from some Roman lead mines, and even from naturally occurring substances.

3.6 Contaminants may still be present above acceptable levels even though the polluting use stopped many years ago. 'Contaminated land' has a specific legal definition which is used in relation to an 'unacceptable risk'

of harm to health. For more information please see Department for Environment, Food and Rural Affairs (DEFRA) web pages.

- 3.7 In principle we will support the redevelopment of contaminated sites where the contamination issue can be successfully addressed and where future uses can be carried out safely. Remediation is particularly important where people have access to ground for gardening, play or planting food for consumption within redeveloped sites.

What should you do if your site is contaminated or potentially contaminated?

- 3.8 In accordance with Planning Policy Statement (PPS) 23: Planning and Pollution Control, if you propose a development on contaminated or potentially contaminated land, it is your responsibility to ensure that contaminated land issues are considered at the planning application stage.
- 3.9 Where contamination is known or suspected on a site or the proposed use would be vulnerable to contamination, we will expect you to provide, as a part of your planning application, the necessary information as outlined in this chapter to determine whether the proposed development is acceptable.
- 3.10 The information required will need to be sufficient for us to determine:
- the existence or otherwise of contamination;
 - the nature of the contamination and the risks it may pose; and
 - whether these can be satisfactorily reduced to an acceptable level.
- Please refer to Annex 2 of PPS23 for further details.
- 3.11 The identification and assessment of land contamination issues is to be carried out by a qualified and experienced consultant, in consultation with the Council's Environmental Health Service. The contamination report is to be submitted with your planning application so that contamination issues can be assessed at the planning application stage and any necessary remediation measures secured through conditions or a Section 106 legal agreement.
- 3.12 The Council's Contaminated Land Strategy sets out how we will:
- deal with contaminated land;
 - make information available to the public; and
 - implement the requirements of the Part IIa of the Environmental Protection Act 1990 and Environment Act 1995. This and other documents are available on the Council's website (www.camden.gov.uk/contaminatedland) and should be referred to where contamination is a potential issue.
- 3.13 If there is any existing contamination (or potential risk of contamination) to ground or surface water or to land with statutory nature conservation designation, either from the existing state of land or from proposed

works, the Environment Agency must be informed and their consent obtained to any works. The English Heritage Archaeological Section should be contacted where contaminated land is included within an Archaeological Priority Area.

Archaeological Priority Area

As specified in the Camden Proposals Map, and Map 4 of the Camden Development Policies, to help protect archaeological remains that might be affected by development. See policy DP25 Conserving Camden's Heritage of the Camden Development Policies for further guidance on the borough's Archaeological Priority Areas.

- 3.14 Your report should comply with the policies and advice given in PPS23 and its annexes. There are also various best practice documents and British Standards that should be followed. The London Boroughs have produced a local guidance document titled *Contaminated Land: A Guide to Help Developers Meet Planning Requirements*. This document provides guidance on what information should be contained within a contamination report and is available on Camden's website.

Supporting documents

PPS23	<p>Planning Policy Statement 23: Planning and Pollution Control. Office of the Deputy Prime Minister, November 2004. www.odpm.gov.uk</p> <p>In particular Annex 2 should be referred to as this section deals specifically with contaminated land issues. The policies and advice contained in PPS23 is not repeated in this guidance and therefore should be consulted for detailed guidance.</p>
Camden Council Website	<p>Information on the Council approach to management of land contamination, information on historical land uses in the Borough and a copy of the London Borough's 'Guide for Developers on Contaminated Land'.</p> <p>http://www.camden.gov.uk/contaminatedland</p>
Department of Food, Environment and Rural Affairs	<p>has published a number of documents on land contamination. These can be found at:</p> <p>www.defra.gov.uk/environment/land/contaminated/index.htm</p>
Environment Act 1995	<p>Available from Stationary Office:</p> <p>www.opsi.gov.uk/acts/acts1995/Ukpga_19950025_en_1.htm</p>

Useful Contacts

Camden Environmental Health Service (Contaminated Land) web page www.camden.gov.uk/contaminatedland has more information on the Council's approach to contaminated land.

English Heritage www.english-heritage.org.uk can provide advice on the approach to contaminated land within Archaeological Priority Areas.

4 Noise and vibration

KEY MESSAGES:

We will ensure that noise and vibration is controlled and managed to:

- Limit the impact of existing noise and vibration sources on new development; and
- Limit noise and vibration emissions from new development.

- 4.1 The impact of noise and vibration can have a major affect on amenity and health and can severely affect people's quality of life.
- 4.2 Policy *DP28 – Noise and Vibration* of the Camden Development Policies aims to ensure that noise and vibration is controlled and managed. It sets out the Council's thresholds for noise and vibration and goes beyond the thresholds set out in Planning Policy Guidance 24: Planning and noise (see below). DP28 contains noise/vibration thresholds for the day, evening and night.



How can the impact of noise and vibration be minimised?

4.3 The main sources of noise and vibration in Camden are generated from:

- Road traffic;
- Railways;
- Industrial uses;
- Plant and mechanical equipment;
- Entertainment uses (such as bars and nightclubs); and
- Building sites.

4.4 For details on how to manage noise and vibration from building sites see section 8 on Construction management plans.

Ways to minimise the impact of noise on your development

Design

- Locating noise sensitive areas/rooms away from the parts of the site most exposed to noises;
- Creating set backs;
- Designing the building so its shape and orientation reflect noise and protect the most sensitive uses;
- Stacking similar rooms (such as kitchens and living rooms) above each other; and
- Positioning non-residential uses closer to the noise source in mixed use developments.

Built fabric

- Insulating and soundproofing doors, walls, windows, floors and ceilings;
- Sealing air gaps around windows;
- Double glazing;
- Including architectural fins (where appropriate); and
- Laminated glass.

Landscaping and amenity areas

- Incorporating planting, landscaping, fencing/barriers and solid balconies to reflect sound.

4.5 Our preference for controlling noise:

- Begins with attempting to reduce noise at its source;
- Then to separate the development (or at least the sensitive parts e.g. habitable rooms) from the source or to use noise barriers; and

- Finally construction materials such as acoustic glazing should be used.

- 4.6 When you consider measures to minimise noise and vibration you also need to take into account our policies on design and crime prevention. You should consider the implications of noise and vibration at the beginning of the design process to enable prevention or mitigation measures to be designed into the scheme. Poorly designed schemes will not be acceptable.
- 4.7 Proposals will be expected to include appropriate attenuation to alleviate or mitigate the impact of noise and vibrations to an acceptable level, as set out in policy *DP28 – Noise and vibration* of the Camden Development Policies. Where appropriate, the Council will consider the cumulative impact of noise sources (for example, air conditioning units).
- 4.8 Everyday domestic activities can also generate noise, e.g. communal entrances and roof terraces. Sufficient sound insulation must be provided between dwellings to prevent the transmission of noise between them, particularly in conversions where new partition walls are often deficient in terms of insulation.

Ways to mitigate noise emitted by your development

Engineering

- Reducing the noise emitted at its point of generation (e.g. by using quiet machines and/or quiet methods of working);
- Containing the noise generating equipment (e.g. by insulating buildings which house machinery and/or providing purpose-built barriers around the site); and
- Protecting any surrounding noise-sensitive buildings (e.g. by improving sound insulation in these buildings and/or screening them by purpose-built barriers).

Layout

- Ensuring an adequate distance between source and noise-sensitive buildings or areas; and
- Screening by natural barriers, buildings, or non-critical rooms in the development.

Administrative

- Limiting the operating time of the source;
- Restricting activities allowed on the site; and
- Specifying an acceptable noise limit.

- 4.9 If your proposal could result in noise and vibration that would cause an unacceptable impact to nearby uses or occupiers, or proposes sensitive uses near a source of noise or vibration and cannot be adequately attenuated then planning permission is likely to be refused.

Developments will be assessed against the thresholds set out in policy DP28.

How will the Council manage the impact of noise and vibration?

- 4.10 Detailed acoustic/noise and vibration information in the form of a report will be required if your development proposes:
- The installation of plant, ventilation or air conditioning equipment;
 - A use that will create significant noise (e.g. new industry, nightclub)
 - A noise-sensitive development in an area where existing noise sources are present (e.g. an existing industrial site, busy road, railway line);
 - A use that will generate a significant amount of traffic.

Noise sensitive developments

Those developments located near sources of noise, including housing, schools and hospitals as well as offices, workshops and open spaces.

- 4.11 The list above is a guide only and you may need to provide noise and vibration information for other developments depending on the circumstances of the site or proposal.
- 4.12 The appropriate amount and detail of information required will depend on the specific circumstances of your proposal. At a minimum you will be expected to provide the following information to support your application:
- Description of the proposal;
 - Description of the site and surroundings, a site map showing noise and vibration sources, measurement locations and noise receivers;
 - Background noise levels;
 - Details of instruments and methodology used for noise measurements (including reasons for settings and descriptors used, calibration details);
 - Details of the plant or other source of noise and vibration both on plan and elevations and manufacturers specifications;
 - Noise or vibration output from proposed plant or other source of noise and vibration, including:
 - Noise or vibration levels;
 - Frequency of the output;
 - Length of time of the output;
 - Features of the noise or vibration e.g. impulses, distinguishable continuous tone, irregular bursts;
 - Manufacturers' specification of the plant, supporting structure, fixtures and finishes;

- Location of neighbouring windows (and use if applicable);
- Details of measures to mitigate noise or fume emissions and vibration;
- Details of any associated work including acoustic enclosures and/or screening;
- Cumulative noise levels of all the proposed and existing units;
- Hours/days of operation.

4.13 Where appropriate the Council will seek a legal agreement to control or reduce noise levels where this is unlikely to be met through the use of a condition attached to a planning permission.

Further information

PPG24	<p>Planning Policy Guidance Note 24: Planning and Noise provide Government guidance on noise. This guidance defines four Noise Exposure Categories (A-D) and outlines what should be done if your proposal falls into one of these categories. Advice is also provided on how to address noise issues and secure amelioration methods through the planning system.</p> <p>www.communities.gov.uk/publications/planningandbuilding/ppg24</p>
DEFRA	<p>The Department of Food, Environment and Rural Affairs provide a number of publications on noise and noise related issues.</p> <p>www.defra.gov.uk</p>
Camden Council website	<p>Camden's Environmental Health web pages provide strategic information on noise in Camden including the results of monitoring that has taken place</p> <p>www.camden.gov.uk/noise</p> <p>Also see <i>Camden's Guide for Contractors working in Camden</i> on the Camden website.</p>
The Mayor's Ambient Noise Strategy	<p>This provides details on the Mayor of London's approach to reducing noise in London.</p> <p>http://legacy.london.gov.uk/mayor/strategies/noise/docs/noise_strategy_all.pdf</p>

5 Artificial light

KEY MESSAGES:

When considering proposals for artificial lighting the Council will consider the:

- need for planning permission;
- need for the lighting;
- design of the lighting; and
- impacts on biodiversity.

5.1 This section provides guidance on the Council's approach to artificial lighting. This guidance should be read in conjunction with policy *DP26 Managing the impact of development on occupiers and neighbours* of the Camden Development Policies.

5.2 Artificial lighting has many benefits, however excessive or poorly designed lighting can be damaging to the environment and result in visual nuisance including by:

- Having a detrimental impact on the quality of life of neighbouring residents;
- Significantly changing the character of the locality;
- Altering wildlife and ecological patterns; and
- Wasting energy.



5.3 Nuisance often occurs due to glare and 'light spillage' because the lighting has been poorly designed.

5.4 *Planning Policy Statement 23 (PPS23): Planning and Pollution Control* enables the Council to take account of the possible obtrusive impact of

lighting and paragraph 3.25 of PPS23 permits us to use conditions or planning obligations to protect the environment.

WHAT IS LIGHT POLLUTION?

Light pollution is the term used to describe any adverse effect of artificial lighting. Light pollution includes:

- Glare - the uncomfortable brightness of a light source when viewed against a dark sky;
- 'Light trespass' – the spread of light spillage the boundary of the property on which a light is located; and
- 'Sky glow' - the orange glow we see around urban areas caused by a scattering of artificial light by dust particles and water droplets in the sky.

Will planning permission be required for lighting?

- 5.5 Structures supporting, and the installation of lighting equipment may require planning permission, especially if they are substantial or affect the external appearance of a building. Planning permission is not required for the carrying out of maintenance which affects only the interior of the building or does not materially affect the external appearance of the building. Temporary lighting schemes generally do not require planning permission.
- 5.6 Planning permission is normally required for:
- the erection of columns to support lighting or other similar structures;
 - the erection of substantial structures or installations that affect the external appearance of a property;
 - external lighting as part of an industrial or commercial scheme;
 - new lighting structures or works which are integral to other development requiring planning permission; and
 - illuminated advertisements, although there are some exceptions such as those indicating medical services and some commercial advertisements on the front of business premises (See Camden Planning Guidance 1 - Design).
- 5.7 You are advised to check with the Planning Service before installing any lighting scheme. You will need to provide the following details:
- Number of lights;
 - Likely lux output;
 - The height of the lighting columns (if applicable); and
 - The area to be lit.
- In accordance with policy DP26 in Camden Development Policies, schemes that would cause harm to amenity will not be permitted.

What information should accompany a planning application?

- 5.8 Where planning permission for lighting schemes is required you will need to submit the information required by paragraph 5.7. We will also expect the submission of the following additional information:
- The design of lights and infrastructure;
 - A plan or plans showing layout of the lights, including orientation of the beams of light;
 - Lighting levels, lumen details, lamp type, wattage;
 - Control systems including types and location of sensors, times lighting will be on; and
 - The need for the lighting, that is, an explanation of what activity the lighting is supporting.

- 5.9 All light installations must be energy efficient and 'Dark Sky' compliant, thereby not causing obtrusive light pollution, glare or spillage (by reference to the British Astronomical Association Campaign for Dark Skies).

Lumen

This is a measurement of the light output from a light source.

Lux

This is a measurement of the light intensity falling on a surface.

Dark sky compliance

To design lighting schemes in order to avoid lighting that extends beyond its intended target and would be inefficient and waste energy. It also avoids glare and light in unwanted areas.

What should you consider when designing lighting?

General lighting requirements

- 5.10 To minimise obtrusive light you should follow the general principles taken from the Institution of Lighting Engineers, Guidance Notes for the Reduction of Obtrusive Light (2005):
- a) Lighting is to be directed downwards wherever possible to illuminate its target. If there is no alternative to up lighting, then the use of shields will help reduce the spill of light to a minimum. Up lighting is a particularly bad form of obtrusive light and contributes to sky glow.
 - b) Lighting is to be designed to minimise the spread of light near to, or above, the horizontal. Again, any light that shines above the horizontal line of the light adds to the sky glow effect.
 - c) Lighting should be designed to the correct standard for the task. Over-lighting is a cause of obtrusive light and also represents a waste of money and energy.
 - d) The main beam angle of all lights proposed directed towards any potential observer is to be kept below 70°. It should be noted that the higher the mounting height, the lower the main beam angle could be. This will help reduce the effect of glare and light spill on neighbouring dwellings, passing motorists, pedestrians, etc.
 - e) Lighting should be directed to minimise and preferably avoid light spillage onto neighbouring properties. Wherever possible use floodlights with asymmetric beams that permit the front glazing to be kept at, or near parallel to, the surface being lit.
 - f) The lights used should be the most efficient taking into account cost, energy use, and the purpose of the lighting scheme required. All lighting schemes should meet British Standards.
- 5.11 We will seek to ensure that artificial lighting is sited in the most appropriate locations to cause minimal disturbance to occupiers and wildlife, while still illuminating the intended area. This includes considering any occupiers located above the lighting source.

- 5.12 Consideration should be given to lighting associated with buildings of special historic and architectural interest in order to protect their special interest and that of the wider area. This applies both to the lighting of such buildings and the impact of the lighting installation when seen by day.

Lighting Infrastructure

- 5.13 The visual effect of lighting infrastructure when viewed in the daytime needs to be considered. These elements can include junction boxes, poles, brackets and cabling. The design, size and colours of the physical infrastructure needs to be carefully considered and should relate to the building it is located on.

Use

- 5.14 The design of lighting should be specific to the use it supports (e.g. for recreation facilities). Hours of lighting should be limited to the times needed to support the use (both in summer and winter) and be restricted through the use of timers and sensors where relevant (e.g. for security lighting).
- 5.15 The Council may seek to secure conditions to any planning permission in order to control the hours of operation of any approved lighting scheme.

Why do impacts on biodiversity need to be considered?

- 5.16 Artificial lighting can often impact on wildlife habitats, particularly where lighting is proposed in open spaces, for example to provide lighting for sports courts and pitches or to improve security (such as along Regents Canal). Artificial lighting can have particularly severe implications for the natural daily rhythms of a range of animals and plants, and therefore sites and habitats identified for their nature conservation value should not be adversely affected by lighting. (See the Local Development Framework Proposals Map for a list of nature conservation sites).
- 5.17 If your proposed lighting is located within or adjacent to areas of open space we will expect that any biodiversity impacts arising from the installation or operation of the lighting is mitigated. This may require a survey to identify if there are any nesting birds in the immediate vicinity or if it is close to an area where bats may hibernate or emerge at feeding time. This is particularly important if the operation of the lighting extends beyond dusk, which is roughly the time bats will come out to forage. See Camden Planning Guidance 3 – Sustainability for further information on our approach to protecting biodiversity.
- 5.18 You should contact Camden's Biodiversity Officer at an early stage to discuss measures to mitigate the impact of lighting schemes on biodiversity.

Further information

PPS23	Planning Policy Statement 23: Planning and Pollution Control. Office of the Deputy Prime Minister, November 2004. www.odpm.gov.uk
DEFRA	The Department of Food, Environment and Rural Affairs has published a number of documents on light pollution. These can be found at: http://www.defra.gov.uk/environment
Environment Act 1995	Available at the Stationary Office: www.opsi.gov.uk/acts/acts1995/Ukpga_19950025_en_1.htm

Useful Contacts

Camden Planning Service www.camden.gov.uk/planning

The Institution of Lighting Professionals www.theilp.org.uk promotes good practice and excellence in lighting schemes.

The Chartered Institute of Building Services Engineers www.cibse.org provides information on appropriate lighting designs and mechanisms.

6 Daylight and sunlight

KEY MESSAGES:

- We expect all buildings to receive adequate daylight and sunlight.
- Daylight and sunlight reports will be required where there is potential to reduce existing levels of daylight and sunlight.
- We will base our considerations on the Average Daylight Factor and Vertical Sky Component.

6.1 Access to daylight and sunlight is important for general amenity, health and well-being, for bringing warmth into a property and to save energy from reducing the need for artificial lighting and heating. The Council will carefully assess proposals that have the potential to reduce daylight and sunlight levels for existing and future occupiers.

6.2 This guidance relates to:

- Camden Core Strategy policy CS5 - *Managing the Impact of Growth and Development*;
- Core Strategy policy CS14 - *Promoting high quality places and conserving our heritage*; and
- Policy DP26 – *Managing the impact of development on occupiers and neighbours* of the Camden Development Policies.

DP26 sets out how the Council will protect the quality of life of building occupiers and neighbours by only granting permission for development that does not cause harm to amenity.

When will a daylight/sunlight report be required?

6.3 The Council expects that all developments receive adequate daylight and sunlight to support the activities taking place in that building.

6.4 A daylight and sunlight report should assess the impact of the development following the methodology set out in the most recent version of Building Research Establishment's (BRE) "Site layout planning for daylight and sunlight: A guide to good practice". Reports may be required for both minor and major applications depending on whether a proposal has the potential to reduce daylight and sunlight levels. The impact will be affected by the location of the proposed development and its proximity to, and position in relation to, nearby windows.

WHAT DOES THE COUNCIL REQUIRE?

The Council will require a daylight and sunlight report to accompany planning applications for development that has the potential to reduce levels of daylight and sunlight on existing and future occupiers, near to and within the proposal site.

Daylight and sunlight reports should also demonstrate how you have taken into consideration the guidance contained in the BRE document on passive solar design; and have optimised solar gain. Please refer to the BRE guidance on daylight and sunlight.

- 6.5 While we strongly support the aims of the BRE methodology for assessing sunlight and daylight we will view the results flexibly and where appropriate we may accept alternative targets to address any special circumstances of a site. For example, to enable new development to respect the existing layout and form in some historic areas. This flexible approach is at the Council's discretion and any exception from the targets will be assessed on a case by case basis.

Daylight

- 6.6 We will aim to minimise the impact of the loss of daylight caused by a development on the amenity of existing occupiers and ensure sufficient daylight to occupiers of new dwellings taking in account overall planning and site considerations. If your proposal will have an unreasonable impact on amenity the planning application will be refused. When assessing daylight issues, we will use the guidelines and methods contained in the BRE's *Site layout planning for daylight and sunlight: A guide to good practice*.
- 6.7 There are two quick methods that can be used to assess access to daylight:

Daylight to new development

- project a 25 degree line, starting 2m above ground level from a wall of your proposed development;
- if none of the existing surrounding buildings extend above this line, then there is potential for good daylighting to be achieved in the interior of your new development.

Daylight to existing development

- project a 25 degree line from the centre of the lowest window on the existing building;
- if the whole of your new development is lower than this line then it is unlikely to have a substantial effect on the daylight enjoyed by occupants in the existing building.

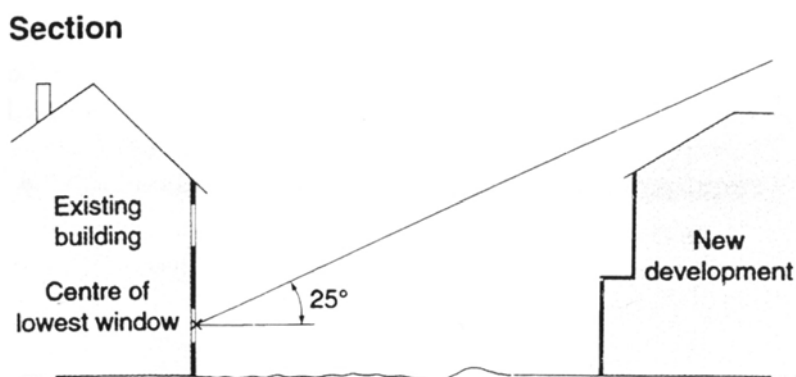

Source: BRE, Site layout planning for daylight and sunlight: A guide to good practice.

- 6.8 For either test, if buildings extend above the 25 degree line a more detailed test needs to be carried out to fully assess either the loss of daylight in existing buildings or the level of daylight achievable in the new development. The two most common measurements of daylight of the more detailed test are the Vertical Sky Component (VSC) and the Average Daylight Factor (ADF).

Vertical Sky Component

The amount of light striking the face of a window

- 6.9 The Vertical Sky Component is expressed as a ratio of the maximum value of daylight achievable for a completely unobstructed vertical wall. The maximum value is almost 40%. This is because daylight hitting a window can only come from one direction immediately halving the available light. The value is limited further by the angle of the sun. This is why if the VSC is greater than 27% enough sunlight should be reaching the existing window. Any reduction below this level should be kept to minimum.
- 6.10 Windows to some existing rooms may already fail to achieve this target under existing conditions. In these circumstances it is possible to accept a reduction to the existing level of daylight to no less than 80% of its former value. Any greater reduction than this is likely to have a noticeable affect on amenity. If this occurs then applications may be refused.

Average Daylight Factor

Average Daylight Factor is a measure of the level daylight in a room. It can be used to establish whether a room will have a predominantly daylight appearance. It provides light levels below which a room should not fall even if electric lighting is provided.

- 6.11 The Average Daylight Factor can be used as a measure to determine whether a room will receive adequate daylight (expressed as a percentage). The ADV takes into account the:
- net glazed area of windows;

- the total area of the room surfaces (ceiling, floor, walls, and windows);
 - the average reflectance; and
 - the angle of visible sky.
- 6.12 If a predominately daylit appearance is required, then the daylight factor should be 5% or more if there is no supplementary electric lighting, or 2% or more if supplementary electric lighting is provided. This figure should be as high as possible to enable occupiers to rely on as much natural light and not use artificial lighting, but as a minimum for dwellings the figures should be 2% for kitchens, 1.5% for living rooms and 1% for bedrooms.
- 6.13 These minimum figures may not be applicable when measuring the impact of new buildings on existing dwellings as the simple preservation of minimum ADFs will not necessarily be seen as an indication of acceptability, especially if the VSC demonstrates a significant worsening in daylight levels. For existing dwellings the Council will consider the overall loss of daylight as opposed to the minimum acceptable levels of daylight. As the BRE guidance suggests, the readings will be interpreted flexibly as their aim is to support rather than constrain natural lighting. However, daylight is only one of the many factors in site layout design. Therefore, when applying these standards in Camden, we will take into consideration other site factors and constraints.
- 6.14 The calculation of the VSC and the ADF is complex. For full details on how these calculations are carried out you should refer to the most up to date version the BRE's "Site layout planning for daylight and sunlight: A guide to good practice". For more complex and larger developments we will expect a daylight study to be submitted with the planning application showing the windows that will be affected and provide before development and post development figures for VSC and ADF.
- 6.15 Other methods can be used to measure daylight and these can be incorporated in daylight and sunlight reports, where necessary, as a supplement to VSC and ADF measurements, such as the No Sky Line (NSL) test contained within BRE guidance.

Sunlight

- 6.16 The design of your development should aim to maximise the amount of sunlight into rooms without overheating the space and to minimise overshadowing.

WHAT DOES THE COUNCIL EXPECT?

New developments should be designed to provide at least one window to a habitable space facing within 90 degrees of south, where practical. This window should receive at least 25% of Annual Probable Sunlight Hours, including at least 5% of Annual Probable Sunlight Hours between 21 September and 21 March, where possible.

Annual Probable Sunlight Hours

The annual amount of sunlight a window receives in an average year.

- 6.17 The BRE's "Site layout planning for daylight and sunlight: A guide to good practice" provides guidance on access to sunlight in relation to:
- site layout, building orientation and overshadowing for new buildings;
 - protecting sunlight to existing buildings, and
 - new and existing gardens and open spaces.
- 6.18 Design for access to sunlight will be specific to the orientation of your site, and the specific design and uses within your proposed development. You should follow the detailed design requirements recommended in the "Sunlighting" section of the BRE document. The Council recognises that not all of the guidance contained within the BRE document, particularly orientation, can be adhered to in all developments due to the dense and constrained urban nature of Camden.

Other considerations**Right to Light**

- 6.19 The right to light is a legal right which one property may acquire over the land of another. If a structure is erected which reduces the light to an unobstructed property to below sufficient levels this right is infringed. A right to light can come into existence if it has been enjoyed uninterrupted for 20 years or more, granted by deed, or registered under the Rights of Light Act 1959. Planning permission does not override a legal right to light, however where a right to light is claimed, this is a matter of property law, rather than planning law. The Council will have no role or interest in any private dispute arising and it will be for the owner or occupier affected to seek a legal remedy.

Supporting documents

- 6.20 For further information on daylight and sunlight please refer to:
Building Research Establishment (BRE). Site layout planning for daylight and sunlight: A guide to good practice.
Copies of this are available directly from BRE.

BRE Bookshop, 151 Roseberry Avenue, London, EC1R 4GB
020 7505 6622
brebookshop@emap.com
www.constructionplus.co.uk

7 Overlooking, privacy and outlook

KEY MESSAGES:

- Development are to be designed to protect the privacy of existing dwellings;
- Mitigation measures are to be included when overlooking is unavoidable;
- Outlook from new developments should be designed to be pleasant;
- Public spaces benefit from overlooking as natural surveillance.

- 7.1 This section aims to ensure that when designing your development you successfully consider the potential impact on the privacy and outlook of neighbouring properties.
- 7.2 This guidance relates to Core Strategy policy CS5 Managing the Impact of Growth and Development and Core Strategy policy CS14 Promoting high quality places and conserving our heritage.
- 7.3 Policy *DP26 – Managing the impact of development on occupiers and neighbours* of the Camden Development Policies outlines how the Council will protect the quality of life of occupiers and neighbours by only granting permission for development that does not cause harm to amenity.

Overlooking and privacy

- 7.4 Development should be designed to protect the privacy of both new and existing dwellings to a reasonable degree. Spaces that are overlooked lack privacy. Therefore, new buildings, extensions, roof terraces, balconies and the location of new windows should be carefully designed to avoid overlooking. The degree of overlooking depends on the distance and the horizontal and vertical angles of view. The most sensitive areas to overlooking are:
- Living rooms;
 - Bedrooms;
 - Kitchens; and
 - The part of a garden nearest to the house.

WHAT IS GOOD PRACTICE?

To ensure privacy, there should normally be a minimum distance of 18m between the windows of habitable rooms of different units that directly face each other. This minimum requirement will be the distance between the two closest points on each building (including balconies).

- 7.5 Where this standard cannot be met we may require you to incorporate some of the following design measures into your scheme to ensure

overlooking is reduced to an acceptable level. Design measures to reduce the potential for overlooking and the loss of privacy include:

- Careful consideration of the location of your development, including the position of rooms;
- Careful consideration of the location, orientation and size of windows depending on the uses of the rooms;
- Use of obscure glazing;
- Screening by walls or fencing; and
- Screening by other structures or landscaping.

7.6 Where landscaping is used as a method of screening, arrangements for ongoing maintenance should be put in place and this may be secured by a planning condition.

7.7 Public spaces and communal areas will benefit from a degree of overlooking due to the increased level of surveillance it can provide.

Outlook

7.8 Outlook is the visual amenity enjoyed by occupants when looking out of their windows or from their garden. How pleasant an outlook is depends on what is being viewed. For example, an outlook onto amenity space is more pleasant than an outlook across a servicing yard. You should design developments so that the occupiers have a pleasant outlook. You should screen any unpleasant features with permanent landscaping.

7.9 When designing your development you should also ensure the proximity, size or cumulative effect of any structures do not have an overbearing and/or dominating effect that is detrimental to the enjoyment of their properties by adjoining residential occupiers. You should carefully consider the location of bin or cycle stores if they are in close proximity to windows or spaces used by occupiers.

7.10 You should take particular care if your development adjoins properties with a single aspect over your development.

7.11 You should note that the specific view from a property is not protected as this is not a material planning consideration.

Further information

Better Places to Live: By Design - A companion guide to PPG3 (ODPM) makes number of design recommendations which recognise the importance of privacy in the home.

Perceptions of Privacy and Density in Housing report available from Design for Homes; 0870 416 3378 or www.designforhomes.org. This report highlights some of the issues facing households living at higher densities, and the implications for future design of buildings.

8 Construction management plans

KEY MESSAGES:

- Construction management plans are required for developments that are on constrained sites or are near vulnerable buildings or structures;
- They are essential to ensure developments do not damage nearby properties or the amenity of neighbours.

- 8.1 The purpose of this guidance is to give details on how construction management plans can be used to manage and mitigate the potential impacts of the construction phase of a development.
- 8.2 All construction and demolition work will cause at least some noise and disturbance. Where construction impact is particularly significant Camden will ensure it is managed through a legally binding construction management plan.
- 8.3 This guidance relates to Core Strategy Policy CS5 Managing the impact of growth and development and policies DP20 Movement of goods and materials, and DP26 Managing the impact of development on occupiers and neighbours of the Camden Development Policies.

When does this guidance apply?

- 8.4 This guidance applies to all development proposals which, having regard to the nature of the surrounding area, are likely to give rise to significant noise and other disturbance during construction. Details on the circumstances in which the Council will expect construction management plans are set out within this guidance.

How should construction management plans be prepared?

- 8.5 Camden's planning policies make it clear that the effect on local amenity and the highway network from construction and demolition is a material planning consideration. Construction management plans are used to set out the measures a developer should take (both on-site and off-site) in order to reasonably minimise and manage the detrimental effects of construction on local amenity and/or highway safety. Usually Camden will secure construction management plans through a Section 106 Agreement, although sometimes for less complicated schemes they may be secured by using a condition attached to planning permission.
- 8.6 Whilst construction management plans are a 'planning led' document they will incorporate mechanisms controlling planning considerations that overlap with other regulatory regimes (particularly highways and environmental protection). Hence, most construction management plans will be an umbrella document managing all impacts of the demolition, excavation and construction process.

- 8.7 Besides ensuring measures under these different regimes are coordinated in one document, construction management plans represent a proactive way of dealing with construction issues. They encourage developers to work with the Council and local people in managing the construction process with a view to ensuring that problems do not arise in the first place.

Circumstances Camden will expect a construction management plan

- 8.8 Whether a construction management plan is required for a particular scheme will be assessed on a case by case basis, although the Council will usually require a construction management plan for larger schemes (i.e. over 10 residential units or 1,000sq m of new commercial floorspace). However, occasionally a relatively large development will have comparatively little impact on its neighbourhood.
- 8.9 Conversely, small schemes on confined or inaccessible sites can have very significant impacts, particularly where the construction process will take place over a number of months (or even years) or outside normal working hours. When assessing smaller developments, special regard should be had to on-site factors that would seriously exacerbate the impact of the development works on the surrounding area. These could include development in residential areas, in close proximity to a school or a care home or very narrow or restricted site access (e.g. development in a mews with no footways). Regard will also be had to the nature and layout of a site. It will be much more difficult to fully absorb or contain the effects of demolition and construction in terms of noise, dust vibration etc within the boundaries of a small constrained site. Furthermore, lack of on-site space for plant, storage of materials and loading and unloading of construction may mean that construction effects will inevitably take place close to the boundary and spill out on to the highway network – a particular issue in much of Camden.
- 8.10 The types of schemes where a CMP will usually be appropriate include:
- Major developments (and some larger scale non major developments);
 - Development where the construction process has a significant impact on adjoining properties particularly on sensitive uses;
 - Developments which give rise to particular 'on-site' issues arising from the construction process (e.g. large scale demolition or complicated or intrusive remediation measures);
 - Basement developments;
 - Significant developments involving listed buildings or adjacent to listed buildings;
 - Developments that could seriously affect wildlife;
 - Developments that could cause significant disturbance due to their location or the anticipated length of the demolition, excavation or construction period;

- Development where site specific issues have arisen in the light of external consultation (where these are supported by objective evidence); and
- Development on sites where constraints arising from the layout or size of the site impact on the surrounding road network.

Contents of a construction management plan

- 8.11 Any construction management plan will manage on-site impact arising from demolition and construction. It will also seek to establish control over construction traffic and how this integrates with other construction traffic in the area having regard to the cumulative effect.
- 8.12 A Section 106 or planning permission securing a construction management plan will contain provisions setting out in detail the measures the final version of the construction management plan should contain. Most construction management plans will be umbrella documents managing all impacts of the demolition, excavation and construction processes. This would include (but is not limited to) issues such as:
- Dust, noise and vibration on site and off site;
 - Traffic management highways safety and highways congestion;
 - Protection of listed buildings (if relevant);
 - Stability of adjacent properties;
 - Protection of any off-site features that may be damaged due to works;
 - Protection of biodiversity and trees; and
 - Preserve the amenity of surrounding residential and other sensitive uses.
- 8.13 A construction management plan is often split into two elements. The first element will be focussed on controlling environmental impacts, pollution and other non-highway related impacts arising from the scheme, having regard to the requirements of the Council's Considerate Contractor Manual and best practice guides from the GLA. In particular this will seek to control hours of operation and monitor and manage air quality, noise, dust and other emissions of other pollutants and location of equipment. The second element will be focussed on traffic control with a view to minimising disruption, setting out how construction work will be carried out and how this work will be serviced (e.g. delivery of materials, set down and collection of skips), with the objective of minimising traffic disruption and avoiding dangerous situations for pedestrians and other road users.
- 8.14 Sometimes the Section 106 will link the construction management plan with a requirement to convene a working group to act as a forum for the developer to meet with local residents and businesses to deal with construction issues as they arise.

- 8.15 Construction management plans will also have to be consistent with any other plans required for the development. For example, a Site Waste Management Plan, which is a legal requirement for works over a certain size which may require the re-use or recycling of materials on-site and therefore the construction management plan will have to reflect that space will be required to sort, store and perhaps crush or recycle materials.
- 8.16 The construction management plan should include the following statement:
“The agreed contents of the construction management plan must be complied with unless otherwise agreed with the Council. The project manager shall work with the Council to review this construction management plan if problems arise in relation to the construction of the development. Any future revised plan must be approved by the Council and complied with thereafter.”

Transport considerations

- 8.17 The details contained within a construction management plan will relate to the nature and scale of the development, however, in terms of assessing the impact on transport the plan should demonstrate that the following has been considered and where necessary the impacts mitigated:
- a) Start and end dates for each phase of construction;
 - b) The proposed working hours;
 - c) The access arrangements for vehicles;
 - d) Proposed routes for vehicles between the site and the Transport for London Road Network (TLRN). Consideration should also be given to weight restrictions, low bridges and cumulative effects of construction on the highway;
 - e) Sizes of all vehicles and the frequency and times of day when they will need access to the site, for each phase of construction;
 - f) Swept path drawings for any tight manoeuvres on vehicle routes to the site;
 - g) Details (including accurate scaled drawings) of any highway works necessary to enable construction to take place;
 - h) Parking and loading arrangements of vehicles and delivery of materials and plant to the site;
 - i) Details of proposed parking bays suspensions and temporary traffic management orders;
 - j) Proposed overhang (if any) of the public highway (scaffolding, cranes etc);
 - k) Details of any temporary buildings outside the site boundary, or overhanging the highway;
 - l) Details of hoardings required or any other occupation of the public highway;

- m) Details of how pedestrian and cyclist safety will be maintained, including any proposed alternative routes (if necessary), and any banksman arrangements;
- n) Details of how traffic associated with the development will be managed in order to reduce congestion;
- o) Arrangements for controlling the movements of large/heavy goods vehicles on and in the immediate vicinity of the site, including arrangements for waiting, turning and reversing and the provision of banksmen, and measures to avoid obstruction of adjoining premises.
- p) Details of any other measures designed to reduce the impact of associated traffic (such as the use of construction material consolidation centres);
- q) Details of how any significant amounts of dirt or dust that may be spread onto the public highway will be cleaned or prevented;
- r) Details of any Construction Working Group that may be required, addressing the concerns of surrounding residents, as well as contact details for the person responsible for community liaison on behalf of the developer, and how these contact details will be advertised to the community;
- s) A statement confirming registration of the site with the Considerate Constructors Scheme;
- t) How the servicing approach takes into consideration the cumulative effects of other local developments with regard to traffic and transport;
- u) Provision for monitoring of the implementation of the CMP and review by the council during the course of construction works;
- v) Any other relevant information with regard to traffic and transport; and

Air quality and climate change considerations

8.18 A method statement should be prepared and adopted as part of the construction management plan to minimise gaseous and particulate matter emissions generated during the Construction Phase. The following best practice measures shall be included in the method statement:

- Techniques to control PM₁₀ and NO_x emissions from vehicles and plant;
- Techniques to control dust emissions from construction and demolition;
- Air quality monitoring; and
- Techniques to reduce CO₂ emissions from construction vehicles.

How will we secure construction management plans?

8.19 Generally a Section 106 agreement (rather than a condition) is the most appropriate mechanism for securing a construction management plan. For larger schemes or developments on constrained sites within heavily

built-up areas where building activities could materially affect the highway construction management plans will always be secured through Section 106s. While the use of conditions is normally preferred to Section 106 Agreements, conditions can only be used to control matters on land within the developer's control. The range of matters typically covered by a CMP, particularly in relation to highways, mean that a Section 106 Agreement will be necessary in most cases.

- 8.20 The level of detail contained in a typical Section 106 also lends itself to the tailored, site-specific approach Camden uses for construction management plans. However, the use of a condition to secure a construction management plan may be sufficient for sites where the building activities associated with the build out can be totally accommodated within the site itself, particularly where these are smaller schemes.

9 Access for all

KEY MESSAGES:

- Well designed, accessible buildings and spaces ensure that local services and facilities are accessible to everyone and increase equality of opportunity and social inclusion. We will seek to ensure the highest standards of access and inclusion in Camden's built environment and public realm.
- We expect all development of buildings and places, including changes of use and alterations to or refurbishment of existing buildings where practical and reasonable, to be designed to be accessible and useable by all to promote equality of opportunity.
- Access should be considered at the beginning of the design process.

- 9.1 A successfully accessible and inclusive environment is one that everyone can benefit from by being able to move freely, independently and uninhibited within the built environment regardless of age or disability.
- 9.2 This guidance applies to all development in Camden that may affect the accessibility of buildings and spaces.
- 9.3 All new developments should incorporate a suitable level of access for everyone and be inclusively designed.
- 9.4 Changes of use, alterations and extensions to existing buildings and spaces should, where practicable and reasonable, be designed to improve access for all.
- 9.5 The planning system is not able to require existing buildings or areas to retrospectively improve access where alterations are not being made.
- 9.6 For developments involving housing, reference should also be made to Camden Development Policies policy DP6 – *Lifetime homes & wheelchair housing* and Camden Planning Guidance on Lifetime homes and wheelchair housing. The accessibility needs are lower for certain sectors of the population, such as students, and so the Council will assess each development proposal on its own merits to determine a suitable level of accessible accommodation to be provided.
- 9.7 Guidance on the provision of parking spaces for drivers with disabilities is contained in Camden Planning Guidance on Vehicle access.
- 9.8 This guidance provides general advice on accessibility and advises on further sources of more detailed information. In particular this guidance relates to Core Strategy policy CS14 - *Promoting High Quality Places and conserving our heritage*; CS6 - *Providing quality homes* and policy DP29 - *Improving access* of the Camden Development Policies.
- 9.9 It is more effective to consider access arrangements from the beginning of the design process as they are an integral aspect of building design.

Overcoming access barriers at a later stage in the project can result in a building or space that is not inclusive and may be inaccessible to many people.

- 9.10 Applicants are advised to consult the Council's Building Control Service at an early stage in the formulation of development proposals to ensure conformity with the relevant requirements relating to access. Satisfying some of the requirements of Part M of the building regulations can affect the size and design of the building and needs to be taken into account at the early design stage.
- 9.11 The following table sets out four key principles which, if put together successfully, should help create an accessible environment:

Principles of access

Key Principle	Features to be considered
1. Approach Parking	<ul style="list-style-type: none"> • Level or adequately ramped • Sufficient width and obstacle free • Firm, durable, slip resistant surfaces • Well lit and clearly identified • Dropped kerbs with tactile surfaces • Contrasting colour on bollards and street furniture • Suitably designed and marked spaces • Spaces as close as possible to all accessible entrances • Dropped kerbs onto a level obstruction free route to the accessible entrance • Appropriately located and signed dropping off point
2. Entrances Lobbies Receptions	<ul style="list-style-type: none"> • Level or adequately ramped and stepped if necessary with appropriately designed handrails • Ramped gradients as shallow as possible • Level area in front of the door • Level threshold • Canopy over manual doors • Easy to open doors • Provision of electronic entrance doors • Sufficiently wide doors • Doors to have contrast. • Need to be of a size and shape to allow a wheelchair user to move clear of one door before opening the second door • Floor surface that does not impede movement, avoid dips or changing surfaces, including mats • Provide hearing enhancement systems and lowered wheelchair accessible counters. • Should be easily identifiable
3. Levels Circulation	<ul style="list-style-type: none"> • Provide a lifting device and suitable stairs to all storeys above and below ground • Ramps for internal changes within a storey • Any raised areas to be accessible to everyone • Adequately wide corridors. • Sufficiently wide doors • Clear, well lit signs • Colour contrast within the building • Corridors free of obstructions
4. Facilities	<ul style="list-style-type: none"> • Adequate provision of wheelchair accessible unisex toilets • Provision of an enlarged cubicle in separate sex toilets • Where shower and changing facilities are included provide wheelchair accessible facilities • Provision of wheelchair accessible hotel bedrooms • Appropriately designed sockets and switches

Additional information

- 9.12 Level access should be provided to the principal entrance in all developments, and is a requirement for all new dwellings. Any new works must not make access any worse than what may have previously existed, in line with Approved Document M of the Building Regulations.
- 9.13 The design of routes around buildings should be clear and free from obstruction, especially to the entrance. Any obstructions should be made clear and avoidable, for example by changes in surface texture.
- 9.14 The above access principles apply mainly to non-residential developments – although the first two will also be applicable to residential developments. In the case of residential development, proposals must meet Lifetime Home Standards as set out in policy *DP6 – Lifetime Homes and wheelchair homes* of the Camden Development Policies. Reference should also be made to Camden Planning Guidance 2 and the section on Lifetime Homes and wheelchair housing.

Design and Access Statements

- 9.15 A Design and Access Statement is a short written and illustrated report which accompanies and supports a planning application. It explains the thinking behind a design and its context in a proposal in a structured way. A Design and Access Statement should:
- Show how the applicant has analysed the site, its setting, and as a result of this assessment, formulated and applied design principles to achieve a good, inclusive design for buildings and public spaces;
 - Include the specific needs of disabled people, by showing how they have been integrated into the proposed development, and how inclusion will be maintained and managed; and
 - Be flexible, adaptable and be able to change with the design of the proposal should any amendments or changes occur.
- 9.16 The level of detail appropriate in an access statement will depend on the size, nature and complexity of the proposal, as a minimum, all should include:
- A short illustrated statement setting out the site and context appraisal, the purpose of the proposed development, a list of design principles and a description of the proposal explaining how the design responds to the appraisal and design principles;
 - A plan of the site, surrounding area or natural form and key features as identified in the appraisal;
 - Annotated sketches and photographs;
 - Important elements of the context that inform the design principles;
 - Plans and elevations of the proposal;
- 9.17 The following points should be taken into account when preparing a Design and Access statement:

- A brief explanation of the applicant's approach to access, with particular reference to the inclusion of disabled people;
- A description of how the sources of advice on accessibility and technical issues will be, or have been, followed;
- Details of any consultations undertaken or planned, including the number of users, particular user need groups (for example, visually impaired, deaf or hard of hearing, ethnic groups, people with learning disabilities and mental health) and the degree to which the process has been influenced by it;
- Details of any professional advice that has been followed, or will be sought, including recommendations from access audits or appraisals;
- An explanation of any specific issues affecting accessibility to, or within, the particular environment being considered, and/or service provision, employment or educational opportunities.
- Details of access solutions adopted to overcome any issues, including those which deviate from recognised good practice;
- Details of the management and maintenance practices adopted, or to be adopted, to maintain features enhancing accessibility (for example, lighting, colour and luminance contrast, door closing forces etc), specialist equipment (for example, induction loops, audible and visual fire alarm systems etc), and staff training; and
- A plan illustrating features such as routes in, out and around the outside of the building, vertical and horizontal circulation routes, positions of accessible car parking bays, the location of public transport, and any other features relevant to the proposal.

9.18 Where good practice cannot be met, the Access Statement should say why this is the case, set out the implications for users, and explain what other measures are being taken to ensure access is provided to the facilities available. See Further Information at the end of this section for links to more detailed guidance.

Listed buildings

- 9.19 Design and access statements are also required for a listed building consent. Where a planning application is submitted in parallel with an application for listed building consent a single combined statement can be submitted which should address the requirements for both.
- 9.20 Measures to facilitate dignified and easy access to and within listed buildings can often be sensitively incorporated without damage to their special architectural or historic interest. However, the Disability Discrimination Act 1995 does not override other legislation such as listed building or planning legislation. Listed Building Consent will almost always be required for works to improve access and in formulating proposals; applicants are encouraged to undertake early discussions with the Council.

- 9.21 English Heritage has produced guidance on this topic titled Easy Access to Historic Buildings (see Further Information for the link). Additional information is also contained in Circular 01/06.

Other considerations

- 9.22 Applicants should note that Design and Access Statements differ from the requirements for Access statements set out in Approved Document M of the Building Regulations, which are only required when specific building control regulations can not be met. Approved Document M of the Building Regulations sets out the requirements to ensure access to and use of a building's facilities are accessible to all.
- 9.23 It may also be appropriate to combine the Design and Access Statements with other statements requested in other sections of Camden Planning Guidance, provided that the requirements of all such statements are adequately addressed.
- 9.24 Part 3 of the Disability Discrimination Act 1995 gives disabled people a right of access to goods, facilities and services. This requires service providers to:
- Alter a barrier feature so that it no longer has effect;
 - Provide a reasonable means of avoiding that feature; or
 - Provide a reasonable alternative method of making the service available.
- 9.25 These requirements apply to all buildings where services are provided to the public and to transportation infrastructure.

Further information

Design and Access Statements	<p>Department for Communities and Local Government (March 2010) Guidance on information requirements and validation: www.communities.gov.uk/publications/planningandbuilding/validationguidance</p> <p>ODPM publication: Planning and Access for Disabled People: A Good Practice Guide www.communities.gov.uk/publications/planningandbuilding/planningaccess</p> <p>Department for Communities and Local Government Circular 01/2006: Guidance on Changes to the Development Control System: Section 3 provides guidance on the legislative position and information required www.communities.gov.uk/publications/planningandbuilding/circularcommunities2</p> <p>The Commission for Architecture and the Built Environment (CABE) 'Design and access statements: how to write, read and use them' www.cabe.org.uk</p> <p>Mayor of London's Supplementary Planning Guidance: Accessible London: Achieving an Inclusive Environment http://legacy.london.gov.uk/mayor/strategies/sds/docs/spg_accessible_london.pdf</p>
Access and the historic environment	<p>English Heritage have published guidance on 'Easy Access to Historic Landscapes' and 'Easy Access to Historic Buildings' which can be found on their website at: www.english-heritage.org.uk/publications/easy-access-to-historic-buildings/</p>
Lifetime Homes and wheelchair housing standards	<p>Lifetime Homes www.lifetimehomes.org.uk</p> <p>Accessible London: Achieving an Inclusive Environment, GLA (April 2004)</p>

10 Wind and micro-climate

KEY MESSAGES:

- Buildings taller than their surroundings may cause excessive wind in neighbouring streets and public areas.
- New developments should consider the local wind environment, local temperature, overshadowing and glare, both on and off the site.
- Where poor wind conditions already exist reasonable attempts must be made to improve conditions generally.

- 10.1 The construction of a building changes the microclimate in its vicinity. Micro-climate refers to local conditions including wind, temperature, overshadowing, access to daylight and general comfort. In particular high-rise buildings can cause high wind velocities at pedestrian level which can create an uncomfortable environment and can even be dangerous. Therefore, the design of your building should not only focus on the building envelope and on providing good indoor environment, but should also include the effect of the design on the surrounding outdoor environment.
- 10.2 The purpose of this guidance is to ensure that appropriate standards are met in the design of buildings and outdoor features to ensure that suitable wind safety and comfort levels are achieved.
- 10.3 This guidance relates to Core Strategy CS14 - *Promoting high quality places and conserving our heritage* and policy DP24 - *Securing high quality design* of the Camden Development Policies.

When does this guidance apply?

- 10.4 This guidance applies to all development that has the potential to change their environment with regard to wind and micro-climate, whether new build or extension. However, the implications for a proposal will vary greatly depending on the nature of the site, the scale of development, its interaction with surrounding sites, and existing buildings and structures on the site.

DEVELOPMENTS LARGE ENOUGH TO CHANGE THEIR LOCAL ENVIRONMENT WILL INCLUDE:

- New or modified buildings that are 18 metres or 5 storeys higher than any surrounding building;
- Significant modifications to the built environment in areas of quantifiable and recognised existing wind nuisance;
- Major proposals adjacent to or incorporating a significant area of public or outdoor space;
- Developments with a large amount of glazing or dark masonry surfaces; or
- A combination of new or modified buildings that cumulatively, will significantly change the wind environment.

Wind environment around buildings

- 10.5 Buildings taller than their surroundings may cause excessive wind in neighbouring streets and public areas. Environmental winds are primarily driven by building massing and should be considered at the early design stages, when changes to achieve design objectives can be made most easily.
- 10.6 We will expect you to consider the local wind environment when designing your scheme, both on and off the site. Where poor wind conditions exist in the area prior to development, a reasonable attempt must also be made to improve conditions in general.

What information should I provide?

- 10.7 Relevant developments are expected to use the Lawson Comfort Level Ratings (set out below). Areas that must be considered are:
- public and private open spaces on and adjacent to the site;
 - outdoor areas on upper levels of the development;
 - entrance and exit areas;
 - shop windows;
 - bus stops;
 - outdoor dining areas;
 - thoroughfares; and
 - pedestrian crossing points.

- 10.8 The Lawson Criteria are used throughout the UK to assess local wind environments and are a widely accepted assessment tool.

The Lawson Comfort Criteria

The Lawson Comfort Criteria is a scale for assessing the suitability of wind conditions in the urban environment based upon threshold values of wind speed and frequency of occurrence. It sets out a range of pedestrian activities from sitting through to crossing the road and for each activity defines a wind speed and frequency of occurrence. If the wind conditions exceed the threshold then the conditions are unacceptable for the stated activity.

Figure 1. Lawson Comfort Level Rating

Lawson Comfort Level Rating	Predominant activity	Mean hourly wind speed exceeded less than 5% of the time
C4 - Long term "Sitting"	Reading a newspaper and eating and drinking	4m/s
C3 - "Standing" or short term sitting	Appropriate for bus stops, window shopping and building entrances	6m/s
C2 - Pedestrian Walking or "Strolling"	General areas of walking and sightseeing	8m/s
C1 - Business "Walking"	Local areas around tall buildings where people are not expected to linger	10m/s

- 10.9 If this applies to your development your planning application should be accompanied by qualitative wind impact statement, prepared by a suitably qualified professional (i.e. wind engineer or similar).
- 10.10 You must firstly carry out a qualitative wind impact assessment. If the results of this show potential negative impacts you will also need to carry out a quantitative assessment. Both assessments must be submitted with your planning application. Your assessment must provide detailed information on how the proposal meets the criteria in the guidance, using quantitative measures (i.e. evidence of wind tunnel testing or similar).

Your Wind Impact Statement must:

- Show how the proposal is expected to affect the local wind environment;
- Describe how the proposal has addressed the local wind environment;
- Include reference to specific features of the site or the development that make a contribution to the wind environment, either positively or negatively, and highlight areas of concern; and

- Reference the proposal's ability to meet the targets of this guidance, and make recommendations regarding the necessity for additional work, as described below.

Your Wind Impact Statement should:

- Compare existing and proposed conditions against the Lawson Comfort Criteria in both summer and winter conditions;
 - Demonstrate how the proposal has adapted to the local wind environment;
 - Reference specific features of the site or the development that make a contribution to the wind environment, both positively or negatively;
 - Highlight areas of concern, and
 - Describe the proposal's ability to adhere to the guidance.
- 10.11 If your proposal does not achieve the targeted ratings or outcomes you must provide sound justification to demonstrate, to the satisfaction of the Council, why your proposal cannot meet the targets. This justification should be prepared in conjunction with, and endorsed by your wind engineer, and must include evidence of the attempts that have been made to address design deficiencies.
- 10.12 If your proposal does not satisfactorily meet the criteria, and you have not provided justification, your proposal may be refused.
- 10.13 A condition may be imposed to secure the achievement of wind speed(s) around the building no greater than those predicted. The Council may require alterations or other remedial measures at the developer's expense if wind speed targets are not met.

Other considerations relating to the wind environment

- 10.14 Your development must not compromise the viability of wind-driven renewable energy generators on adjacent and nearby sites. Where wind-driven energy generators are likely to be significantly affected, you are responsible for ameliorating the loss by moving, modifying or replacing the installation, or by incorporating equivalent renewable energy generation within your site.
- 10.15 Where a development affects the viability of an existing wind-driven renewable energy generator, and the solution is to modify the installation off-site, all approvals, expenses and risks are the responsibility of the applicant. This requirement will be incorporated as a condition or in a S106 agreement relating to any approval. Where additional renewable energy capacity is to be installed on site, this will be assessed in conjunction with other renewable energy installations. (Note: additional capacity that is gained by installations off-site should be credited toward the onsite requirement for the development)
- 10.16 Wind environment also impacts on natural ventilation systems. Natural ventilation must also be considered in building design.

Other influences on micro-climate

Local heat

- 10.17 Local air temperature can be affected by your building's ability to absorb heat during the day and release it at night. This cumulative effect of this happening across London results in the urban heat island effect. We strongly encourage green roofs, brown roofs, green walls and soft landscaping in all developments to reduce this affect. You can also consider light coloured building materials so unnecessary heat is not absorbed by your building. See Camden Planning Guidance 3 – Sustainability for further guidance on these issues.

Overshadowing

- 10.18 You should consider the design of your proposal carefully so that it does not overshadow windows to habitable rooms or open spaces and gardens. This may be particularly difficult in central London. However, it will be particularly important in Central London to prevent overshadowing of amenity space and open spaces given the limited amount of open spaces and the existing amount of overshadowing.

Glare

- 10.19 Glare is uncomfortably bright sunlight reflected from a building façade. It is generally caused by tall, fully glazed and sloping facades with reflective finishes that reflect the sun. Tall buildings should be designed to avoid this and use materials that do not result in glare.

Further information

General guidance on design principles	By Design: Urban Design in the Planning System – Towards Better Practice, DETR/CABE, 2000
Tall buildings	Guidance on tall buildings, English Heritage/CABE, 2007
Urban design in relation to the historic environment	Understanding Place, English Heritage 2010; and Building in Context, English Heritage/CABE, 2002

11 Open space, outdoor sport and recreation facilities

KEY MESSAGES:

- If your scheme is over a certain size it is expected to make a contribution towards the provision of public open space in the borough;
- Our priority is for the provision of public open space on-site, therefore it is important this is taken into account at the design stage of your scheme;
- Other forms of public open space contributions could be provision off-site or as a payment in lieu.

- 11.1 This guidance gives details of how the Council expects development to provide for a variety of public open space, outdoor sport and recreation facilities. It sets out:
- Which developments are expected to make provision for open space, outdoor sport and recreation opportunities;
 - The amount of open space we expect;
 - The type of open space and outdoor sport and recreation facilities we expect;
 - How we will calculate the open space expected for a specific development; and
 - The Council's priorities for how open space, outdoor sport and recreation facilities will be provided.

- 11.2 This guidance primarily relates to:

Core Strategy Policies:

- CS5 – Managing the impact of growth
- CS15 – Protecting and improving our parks and open spaces and encouraging biodiversity

Development Policies:

- DP26 – Managing the impact of development on occupiers and neighbours
- DP31 – Provision of, and improvements to, open space and outdoor sport and recreation facilities.

Which developments are expected to contribute towards open space, outdoor sport and recreation facilities?

- 11.3 As set out in paragraph 31.6 the Camden Development Policies document you will need to make a contribution to the provision of these facilities in the borough if your development falls within the following categories:

- Five or more additional dwellings;
- Student housing schemes creating an additional 10 or more units/rooms or occupiers; and
- Developments of 500sq m or more of any floorspace that are likely to increase the resident, worker or visitor populations of the borough.



How much open space do we expect?

- 11.4 Development Policy *DP31 – Provision of, and improvements to, open space and outdoor sport and recreation facilities* sets out the amount of open space to be provided by developments as follows:

Figure 2. Amount of open space to be provided by land use

Development type	Open space provision
Residential (all types)	9 sq m per occupier
Commercial development	0.74 sq m per worker

- 11.5 Non-residential developments for higher education are considered to generate requirements per occupier (including employees and students) at the same rate as commercial developments.

What types of open space, outdoor sport and recreation facilities will we expect?

- 11.6 Open space standards relate specifically to public open space. The Council acknowledges the private amenity space and other private open land can reduce pressure on the use of public open space. However public open spaces provide opportunities for social interaction and a focus for community activities. Private spaces cannot be used as a substitute for public open space.

- 11.7 Public open space includes a wide variety of different facilities that are available to the public:
- Green amenity spaces, including natural and semi-natural spaces;
 - Active spaces for outdoor sport and recreation and for children’s play; and
 - Civic spaces.
- 11.8 Green amenity spaces can be formal or informal parks and gardens or other landscaped areas, which provide areas of passive recreation for all age groups and attractive green areas within the urban environment. They are intended to be attractive spaces for people to enjoy using or viewing. This type of open space can include areas of natural or semi-natural green spaces, which support wildlife conservation and biodiversity and promote environmental education and awareness.
- 11.9 Active spaces are areas of grassed or artificial surfaces providing opportunities for sport and recreation together with ancillary facilities such as changing rooms and flood lighting. These include playing pitches, courts, greens, athletic tracks and Multi Use Games Areas (MUGAs). Formal recreation areas may be stand-alone facilities or may form part of a larger open space (e.g. the tennis courts and bowling greens at Hampstead Heath).
- 11.10 Civic spaces are hard surfaced areas designed for pedestrians, such as piazzas, which often provide a setting for civic buildings.
- 11.11 Given the amount of hard surfaces in Camden, our priority will generally be for green spaces, especially in the south of the borough. Paragraphs 11.12 to 11.17 give more details of specific types of public open space.

Children’s play space and young people’s recreation space

- 11.12 These are formal or informal areas designed to engage children or young people. Formal spaces are designated areas for children and young people containing a range of facilities and an environment that has been designed to provide focused opportunities for outdoor play. There are three categories of formal children’s play space defined by the National Playing Fields Association (NPFA).
1. LAP - Local Area for Play;
 2. LEAP - Local Equipped Area for Play;
 3. NEAP - Neighbourhood Equipped Area for Play.
- 11.13 Informal spaces are less well defined areas and can be incorporated into smaller spaces such as local footpaths where wide enough or town centre spaces. It involves incorporating features that children can play with such as fountains or objects to climb.
- 11.14 Contributions to children’s play space and young people’s recreation space can include formal and informal areas. We must be satisfied that any informal space has been sufficiently designed to meet the requirements of children and young people.

Natural and semi-natural green spaces

- 11.15 These include sites and areas formally recognised for their nature conservation value such as Sites of Special Scientific Interest, Sites of Nature Conservation Importance and Local Nature Reserves as well as other areas with biodiversity such as gardens, parks and open spaces.
- 11.16 In exceptional circumstance, generally in areas deficient in nature conservation sites, we may consider the inclusion of a biodiverse green roof, brown roof or green wall as a contribution towards natural and semi-natural green spaces in the borough. For more information about areas of deficiency please see Appendix A to this section. For more information about green roofs, brown roof and green walls please see Camden Planning Guidance 3 – Sustainability.

Allotments and Community Gardens

- 11.17 Allotments and community gardens provide opportunities for people to grow food as part of the long term promotion of sustainability, health and social inclusion.

What type of open space, outdoor sport and recreation facilities are expected for specific development types?

- 11.18 For this guidance, and in line with *Camden's Open space, Sport and Recreation Study Update 2008* we have identified the following five broad categories of open space:
- Public amenity open space;
 - Children's play space and young people's recreation space;
 - Natural and semi-natural green space;
 - Allotments and community gardens; and
 - Outdoor sport and recreation.
- 11.19 We recognise that not every type of development will generate a need for all types of open space, outdoor sport and recreation facilities. For example, housing for older people will not generate demand for children's play space. Figure 3 sets out the types of open space that are likely to be needed for various types of development.

Figure 3. Type of open space to be provided by development

	Amenity open space	Children's playspace	Natural green-space	Outdoor sport facilities	Allotments / Community gardens
Self-contained homes (Use Class C3)	✓	✓	✓	✓	✓
Student housing	✓	x	✓	✓	x
Housing for older people	✓	x	✓	x	✓
Commercial	✓	x	✓	✓	x

Source: adapted from Camden Open Space, Sport and Recreation Study Update 2008.

- 11.20 The requirement for 9 sq m of public open space per residential occupier and 0.74 sq m of public open space per employee/ student (commercial/ higher education developments) should generally be divided into different types of open space approximately as set out in Figure 4.
- 11.21 In Camden the potential to add to outdoor sports facilities for adults is limited. Provision for outdoor sports will be sought within the overall requirement of 9 sq m per residential occupier where an opportunity for provision arises. Where a development provides public facilities for outdoor sports these will reduce the requirement for other types of open space.
- 11.22 The Camden Open Space, Sport and Recreation Study Update 2008 derived a separate standard for allotments of 0.9 sq per residential occupier. The study indicated that additional space to grow food could only be provided by taking a flexible approach including community gardens, roof gardens, temporary use of vacant sites and converting parts of existing open spaces. Although the standard is not included within the 9 sq m overall requirement, paragraph 31.7 of the Camden Development Policies document indicates that allotments and community gardens are a Council priority. Provision will be sought wherever an opportunity arises, and will be considered to reduce the requirement for other types of open space.

**Figure 4. Break down of open space by type of provision
Residential Developments (all types)**

Type of open space	Provision per adult	Provision per child
Amenity open space	5 sq m	4 sq m
Children's playspace (where applicable)		2.5sq m
Natural green space	4 sq m	2.5 sq m

Commercial / higher education (non-residential)

Type of open space	Provision
Amenity open space	0.4 sq m per person
Natural green space	0.34 sq m per person

How we will calculate the open space expected for a specific development

- 11.23 Figure 5 below shows the figures we will use to assess open space requirements for individual residential, commercial and higher education developments. The figures are based on the break down of open space requirements in Figure 4 and the occupancy rates recommended by the Camden Open Space, Sport and Recreation Study Update 2008. The occupancy rates are given in Appendix B to this section.

Figure 5. Open space required for specific developments

Self-contained homes in Use Class C3	Amenity open space	Children's play space	Natural green space	Total
One bedroom home	6.5 sq m		5.2 sq m	11.7 sq m
Two bedroom home	9.2 sq m	0.6 sq m	7.2 sq m	17.0 sq m
Three bedroom home	12.8 sq m	2.9 sq m	9.5 sq m	25.2 sq m
Four bedroom home	14.1 sq m	3.6 sq m	10.2 sq m	27.9 sq m
Student housing, hotels and hostels				
Single room	5.0 sq m		4.0 sq m	9.0 sq m
Double room	10.0 sq m		8.0 sq m	18.0 sq m
Commercial/ higher education development				
Per 1,000 sq m gross external area	21.6 sq m		17.9 sq m	38.9 sq m

- 11.24 Appendix D sets our worked examples showing the open space required for a number of different development types and sizes.

How public open space will be provided

11.25 There are three ways in which you can make a contribution to public open space in Camden:

1. On site provision of new public open space;
2. Off site provision of new public open space;
3. Providing a financial contribution in lieu of direct provision.

On site provision of new public open space

11.26 If your development is located in an area deficient in public open space or with an under provision of public open space we expect provision of new public open space on the development site (see Appendix A to this section and Core Strategy Map 7). This is in accordance with paragraph 31.7 of the Camden Development Policies document. Paragraph 31.7 and accompanying Table 1 also set out other developments that are expected to provide open space on-site. Some on-site provision is expected for residential development adding 60 or more homes and commercial development adding 30,000 sq m or more.

11.27 The amount and type of public open space that can be achieved on-site will be determined by the size of the site. Where children's play facilities are required as a result of the development, priority should be given to the provision of these facilities. On sites already covered by development, and where appropriate access may have to be restricted to the occupiers of the building, the provision of a roof garden as a contribution to public open space may be considered. If a roof garden is to be considered as public open space, as a minimum it should be able to be used by all the occupants of the building.

11.28 Any new public open space that is provided as part of your development should be:

- Large enough to cater effectively for the intended users;
- Designed to be fully accessible, where possible;
- Designed in consultation with the Council's Open space team; and
- Practical to maintain.

11.29 Where you are required to make a contribution to public open space we will ensure that the type of open space you provide best meets the needs of the occupiers or users of the development. You should consider designing your open space carefully to enable different types of open space to be located together or adjacent to each other to complement the overall provision of open space, sport and recreation opportunities.

11.30 We will expect new open space provision to be publicly accessible, however in exceptional circumstances, for example where an existing open space is in private ownership or already has restricted access we may accept an alternative access arrangement.

Off site provision of new public open space

- 11.31 Where a site cannot provide public open space on-site, the preferred option will be provision of new suitable open space off-site. Once again this is especially important where a site does not have access to existing open space in accordance with the distance thresholds (see Appendix A to this section). The new provision should be within the distance threshold for the type of public open space to be provided. For example, if a developer is to provide a children's play area of 100 sq m this should be provided within 50 m walking distance of the development, if amenity open space is to be provided, this should be a maximum of 280 m from the development. If the developer is to provide for a new formal recreation area such as a multi-use games area, this should be provided within 1,200 m of the development.
- 11.32 We will accept the provision of public access to an existing open space that currently has restricted access as a contribution to off-site public open space provision.

Providing a financial contribution in lieu of direct provision

- 11.33 The Council may agree to accept financial contributions in place of direct provision of new public open space where the development site is too small to incorporate on-site open space and the densely built up character of Camden prevents direct provision of off-site public open space. Financial contributions may be used for:
- The creation of an area of public open space, including buying additional land or leasing it at a nominal rate;
 - Improving access to existing public open space;
 - Opening up access to existing private open space;
 - Fit out of a new or existing open space, or some elements of the open space; and
 - Qualitative improvements to existing open space.
- 11.34 Financial contributions may be pooled to create, fit out, improve or provide access to open space. For example, where the Site Allocations Document indicates that new public open space is required on a development site, contributions from other developments within 280 m may be pooled to facilitate the creation of the new public open space.
- 11.35 Financial contributions are calculated on the basis of the costs and requirements set out in Figure 6.. We will aim to spend the collective amount in the proportions set out in Figure 6 and within the same ward as the contributing development where possible. However individual financial contributions will be spent on priorities identified in:
- Camden's open space, sport and recreation study update 2008;
 - Camden's open space strategy;
 - Camden's biodiversity action plan;
 - Camden's play strategy;
 - Camden's sport strategy;

- Individual park management plans.

11.36 A financial contribution is based on the:

- Capital cost of providing new public open space;
- Cost of maintenance for the first 5 years; and
- Cost for the open space team to administer the contribution and design schemes.

Figure 6. The financial contributions

	Capital cost	Maintenance	Design and admin
Self-contained homes in Use Class C3			
One bedroom home	£385	£386	£46
Two bedroom home	£663	£561	£80
Three bedroom home	£1,326	£832	£159
Four bedroom home	£1,537	£921	£184
Student housing, hotels and hostels			
Single room	£297	£297	£37
Double room	£593	£594	£71
Commercial/ higher education development			
Per 1,000 sq m	£1,265	£1,284	£152

- 11.37 These aggregate contributions are based on provision of public open space, natural green space and (where applicable) children's play space. Specific contributions to allotments and community gardens and to outdoor sport and recreation provision will be sought on a case by case basis depending on whether there are opportunities to add to provision or are local facilities that need to be maintained.
- 11.38 The calculation of the aggregate contributions is set out in Appendix C to this section. Appendix C includes break down of the capital cost by open space type. This may be needed for developments where a proportion of the open space requirement is met on site or where adequate open space of some types is already available locally.
- 11.39 Payments for maintenance and design and administration are explained in paragraphs 11.45 to 11.50. They have not been aggregated with capital costs as payments will sometimes be required need to be calculated separately (eg where open space will be provided by the developer but maintained by the Council. The Council may also wish to draw separately on funds for capital works, funds for maintenance and funds for design and administration.
- 11.40 The contributions may be adjusted upwards or downwards according to the particular circumstances of the development. They provide a starting

point for negotiations between the Council and developers. The scale of financial contributions will be reviewed and updated as appropriate.

- 11.41 Appendix D to this section sets out worked examples showing the contributions required for a number of different development types and sizes.

Providing a combination of open space provisions

- 11.42 Your development may contribute to public open space through one of the ways listed above or by a combination of them. To determine the amount and type of public open space you are expected to provide, either on-site or off-site we will consider the:

- Type and size of the existing public open space provision within the distance threshold of your development; and
- Size and likely users of your development.

- 11.43 For example, if you propose a residential development located within 280 m of a small local park you may not be required to contribute to amenity open space, but may still be required to contribute to children's play facilities or a formal recreation area if suitable facilities do not exist within the distance threshold of the development.

- 11.44 In all cases a legal agreement will be required to secure the ongoing use of the open space provided as public open space, or to secure the financial contribution in lieu of direct provision.

Maintenance

On or off-site provision

- 11.45 Where you provide a contribution towards public open space outdoor sport or recreation facilities (either on-site or off-site), the Council will need to be satisfied that it has been properly laid out and completed and that suitable contractual arrangements for its long-term maintenance have been put in place. If you provide new public open space (either on-site or off-site) you will be expected to transfer the space to the Council to maintain and retain for such use.

- 11.46 Where your new public open space is to be transferred to us, you will normally be required to remain responsible for its maintenance for an initial establishment period of 5 years. After this time, we will take full responsibility for the maintenance of that public open space.

Financial contribution

- 11.47 If you make a financial contribution in lieu of direct provision, whether it is for substantial qualitative or accessibility improvements to existing sites already maintained by the Council or for the provision of a new public open space, we will expect you to provide a commuted sum for the maintenance of these facilities for a period of five years.
- 11.48 Where your new public open space is not to be transferred to the Council a commuted sum for maintenance will not be required. However,

if you choose to retain control of your public open space, we will need to be sure that adequate provision for the maintenance and access of that public open space is in place.

- 11.49 In ALL cases a legal agreement will be required to secure the maintenance of public open space over a defined period or to secure the financial contribution in lieu of direct maintenance.

Design and administration

- 11.50 For payments in lieu of providing public open space, on-site or off-site payments we will also require a 12% contribution towards the costs of our open space team to administer the financial contribution and to plan and design works within our open spaces.

Further information

Open Space, Sport And Recreation Study	Camden's open space, sport and recreation study update 2008 provides an assessment of open space, sport and recreation provision and demand in the borough. www.camden.gov.uk/planning
Biodiversity Action Plan	Camden's Biodiversity Action Plan provides Camden's priorities for improving our greenspaces and biodiversity. www.ukbap-reporting.org.uk/plans/lbap.asp
PPS17	Planning Policy Guidance 17 – Planning for open space and its companion guide provide policy and guidance for the provision of open space including the quantitative and qualitative considerations. www.communities.gov.uk
Mayor of London's Supplementary Planning Guidance	The Mayor of London's Supplementary Planning Guidance Providing for children and young people's play and informal recreation provides guidance and examples of how to incorporate space for children and young people. http://legacy.london.gov.uk/

Appendix A

Public Open Space Deficiency

Figure 7 shows the maximum distance that people can reasonably be expected to travel on a regular basis to use different types of open space. Amenity open space and children's play space should be available within easy walking distance of the development to which they relate. People are generally willing to travel further to use recreation areas providing outdoor sport facilities or to larger parks.

Figure 7. Distance threshold for different types of public open space

Type of public open space	Minimum size (where applicable)	Distance from development to public open space
Public amenity open space		280m*
Formal recreation area		1.2 km
Play Space		
LAP	100sq m	50m*
LEAP	400sq m	280m*
NEAP	1000sq m	500m*
Natural greenspace	Any	500m
Allotments and community gardens	Any	Any

*This distance is the actual walking distance, taking into account local circumstances, such as the location of entrance gates, street patterns, the severance effects of railway lines or heavy traffic flows that could all reduce the accessibility of open spaces.

(Based on Guide to preparing Open Space Strategies: Best practice guidance of the London Plan, Mayor of London, 2002)

Camden Core Strategy Map 7 shows areas of the borough that are deficient in public open space.

AREAS DEFICIENT IN PUBLIC OPEN SPACE

Areas more than 280m walking distance away from a public open space with a multi-functional role, that is a space over 0.25ha (2,500sq m).

Core Strategy policy CS13 also refers to areas with an under-provision of open space. These are areas with access to open space, but the provision is not sufficient to meet the level of local need due to the number of children, dwelling density, and social disadvantage in the area. These are shown in Figure 4.4 of Camden's Open Space, Sport and Recreation Study Update.

Both components are needed to ensure that everyone is within an appropriate distance of public open space based upon their needs and to ensure that people are not prevented from accessing that open space as a result of prohibitive costs. Contributions to open space will be

encouraged within the distance thresholds for the particular type of open space to be provided.

Paragraph 15.18 of Camden's Core Strategy indicates that residents and visitors further than 1 km away from a metropolitan or borough Site of Nature Conservation Importance (SNCI) are considered to have poor access to the natural environment. Core Strategy Map 8 shows all areas greater than 500 m from an SNCI as deficient in access to nature conservation areas.

AREAS DEFICIENT IN NATURE CONSERVATION SITES

Areas more than 500m walking distance away from a Borough or Metropolitan level Site of Nature Conservation Interest.

Appendix B

Occupancy rate by development type

The Camden Open Space, Sport and Recreation Study Update 2008 recommends calculating occupancy rates and child yields on the basis of the London Housing Survey 2002 and DMAG briefing 2005/25. The occupancy rates are shown in Figure 8.

Figure 8. Occupancy rate for C3 homes based on the London Housing Survey and DMAG briefing 2005/25

Self-contained homes in Use Class C3	Total persons	Children (average)	Adults (net)
One bedroom home	1.3	0.04*	1.3
Two bedroom home	1.9	0.25	1.65
Three bedroom home	2.8	1.15	1.65
Four bedroom home	3.1	1.44	1.66

Source: Camden Open Space, Sport and Recreation Study Update 2008.

*The average child yield for a one bedroom home equates to 1 child per 25 homes, which would not generate a meaningful play space requirement, and has been treated as 0.

Occupancy rates for student housing, hotels and hostels are assumed to be one person per single bedroom and two people per double bedroom.

The study recommends assuming an employee density of one worker per 19 sq m (gross external area) for commercial floorspace. This generates an occupancy rate of 52.6 employees per 1,000 sq m (gross external area). Non-residential developments for higher education are considered to generate the same number of occupants (including employees and students) as commercial developments.

Appendix C

Calculation of financial contributions

This appendix shows how we have calculated the financial contributions for provision or enhancement of public open space.

In addition to this capital cost, you will be expected to pay a commuted sum to cover:

- Maintenance of the facility and open space provision over a 5 year period; and
- Designing the new open space works and administering the financial contribution by Camden's open space team.

Figure 9. Capital cost of provision

Type of public open space	Capital cost
Amenity open space	£46.22 per sq m
Children's play space and young people's recreation space	£199.48 per sq m
Natural and semi-natural greenspace	£16.42 per sq m
Allotments/Community Gardens	£32.50 per sq m

Source: Camden Open Space, Sport and Recreation Study Update 2008

Figure 5 sets out the break down of open space requirements for developments of specific sizes. The capital costs have been aggregated in accordance with Figure 5 as set out in Figure 10.

Figure 10. Calculation of financial contribution to capital cost

Capital cost per square metre	Amenity open space £46.22 psm	Children's play space £199.48 psm	Natural green space £16.42 psm	Total (amenity space + play space + green space)
Self-contained homes in Use Class C3				
One bedroom home: space required	6.5 sq m		5.2 sq m	
Space required x cost per square metre	£300		£85	£385
Two bedroom home: space required	9.2 sq m	0.6 sq m	7.2 sq m	
Space required x cost per square metre	£425	£120	£118	£663
Three bedroom home: space required	12.8 sq m	2.9 sq m	9.5 sq m	
Space required x cost per square metre	£592	£578	£156	£1,326
Four bedroom home: space required	14.1 sq m	3.6 sq m	10.2 sq m	
Space required x cost per square metre	£652	£718	£167	£1,537
Student housing, hotels and hostels				
Single room: space required	5 sq m		4 sq m	
Space required x cost per square metre	£231		£66	£297
Double room: space required	10 sq m		8 sq m	
Space required x cost per square metre	£462		£131	£593
Commercial/ higher education development				
Space required per 1,000 sq m	21.0 sq m		17.9 sq m	
Space required x cost per square metre	£971		£294	£1,265

Contributions to maintenance costs

In addition to capital costs, the Council has established a maintenance cost of £6.60 per square metre per year, based on the 2006 Parks and Open Spaces Budget, plus inflation.

The standard length of time developers should provide for maintenance of new and enhanced public open space is 5 years.

Commuted sums for maintenance of public open space are calculated as follows: open space requirement (sq m) x £6.60 x 5. This equates to £33 per square metre of open space required.

Contributions to the cost of design and administration

Design and administration costs have been assessed as 12% of the capital cost of the open space provision or contribution.

Appendix D

Worked Examples

Worked Example 1:

Public open space provision for self-contained homes (C3)

A residential development of 16 new homes provides the following mix of dwelling sizes: 3 x 1-bedroom, 8 x 2-bedroom, 4 x 3-bedroom and 1 x 4-bedroom. The open space requirement can be calculated as follows:

Home size	No of homes	x open space requirement per home (sq m) from Figure 5	= total requirement (sq m)
One bedroom home	3	11.7	35.1
Two bedroom home	8	17.0	136.0
Three bedroom home	4	25.2	100.8
Four bedroom home	1	27.9	27.9
Total for all homes	16		299.8

The total open space requirement for this 16 home scheme would be approximately 300 sq m.

Worked Example 2:

Public open space provision for non-residential development

An office development provides 1,500sq m of additional floorspace. The open space requirement can be calculated as follows:

Additional floorspace	÷ 1,000 to give floorspace in thousands of sq m	x open space requirement per 1,000 sq m from Figure 5	= total requirement (sq m)
1,500 sq m	1.5	38.9	58.35

The total open space requirement for this additional non-residential floorspace would be approximately 60 sq m.

Worked Example 3:

Payment in lieu of open space provision for non-residential development – capital costs

As per example 2, an office development provides 1,500 sq m of additional floorspace. The payment in lieu of open space provision can be calculated as follows:

Additional floorspace	÷ 1,000 to give floorspace in thousands of sq m	x capital cost per 1,000 sq m from Figure 6	= total payment for capital costs
1,500 sq m	1.5	£1,265	£1,897.50

The payment in lieu of open space provision for this additional non-residential floorspace based on capital costs would be £1,897.50. However, we would also expect payments towards maintenance and design and administration – see example 5.

Worked Example 4

Payment in lieu of open space provision for student housing – capital costs

A student housing scheme provides 30 single rooms and 10 double rooms. The payment in lieu of open space provision can be calculated as follows:

Bedroom type	No of bedrooms	x capital cost per bedroom from Figure 6	= total payment for capital costs
Single	30	£297	£8,910
Double	10	£593	£5,930
Total for all bedrooms	40		£14,840

The payment in lieu of open space provision for this student housing based on capital costs would be £14,840. However, we would also expect payments towards maintenance and design and administration – see example 5.

Worked Example 5

Payment in lieu of open space provision for self-contained homes (C3) – all costs

A residential development of 5 new homes provides the following mix of dwelling sizes: 1 x 1-bedroom, 3 x 2-bedroom, 1 x 3-bedrooms. The total payment in lieu of open space provision can be calculated in 4 stages

Stage 1 – Capital costs

Home size	No of homes	x capital cost per home from Figure 6	= total payment for capital costs
One bedroom home	1	£385	£385
Two bedroom home	3	£663	£1,989
Three bedroom home	1	£1,326	£1,326
Total for all homes	5		£3,700

The payment in lieu of open space provision for this 5 home scheme based on capital costs would be £3,700.

Stage 2 – Maintenance costs

Home size	No of homes	x maintenance cost per unit from Figure 6	= total payment for maintenance
One bedroom home	1	£386	£386
Two bedroom home	3	£561	£1,683
Three bedroom home	1	£832	£832
Total for all homes	5		£2,901

The payment in lieu to cover maintenance of new or enhanced open space for this 5 home scheme would be £2,901.

Stage 3 – Design and administration costs

Home size	No of homes	x design and administration cost per unit from Figure 6	= total payment for design and administration
One bedroom home	1	£46	£46
Two bedroom home	3	£80	£240
Three bedroom home	1	£159	£159
Total for all homes	5		£445

The payment in lieu to design and administration for new or enhanced open space for this 5 home scheme would be £445.

Stage 4 – Sum of all costs

The three separate types of costs will not usually be aggregated for the Council's purposes (see paragraph 11.39). However, for the guidance of developers, the three costs can be added together.

In this example, the total cost to the developer would be:

Capital costs	£3,700
+ maintenance costs	£2,901
+ design and administration costs	£445
= grand total	£7,046

12 Planning for healthy communities

KEY MESSAGES:

- Planning has a significant role in improving health;
- Applicants should consider the impact of the development on health;
- Applicants should submit a completed health checklist with applications.

- 12.1 It is widely recognised that the health and well-being of individuals is directly influenced by a number of related factors. These include:
- housing;
 - employment;
 - education;
 - access to green and open spaces;
 - social capital and community cohesion;
 - climate change and sustainability;
 - community safety;
 - building and urban design;
 - air and noise pollution;
 - diet and food;
 - waste; and
 - other factors.
- 12.2 Planning and the built environment have a significant role in influencing, both directly and indirectly, all of these health determinants.
- 12.3 In the UK, the 2010 Marmot review, Fair Society and Healthy Lives, also identified a number of recommendations to help deliver one of its objectives to: create and develop healthy and sustainable places and communities. These include:
- active travel;
 - provision of good quality open and green spaces;
 - improving the food environment;
 - energy efficiency of housing; and
 - to fully integrate planning, transport, housing, environmental and health systems to address the social determinants of health.



- 12.4 Camden's Core Strategy reflects health across the strategy as a cross-cutting theme and so almost all the policies in the Core Strategy will have an impact on health. For example, the following policies all have an influence on health and well-being:
- CS6 - *Providing quality homes;*
 - CS15 - *Protecting and improving our parks and open spaces and encouraging diversity;* and
 - CS11 - *Promoting sustainable and efficient travel.*
- 12.5 Policy CS16 - *Improving health and well-being* brings these policies together to ensure they are all working to tackle health inequalities and improve well-being. CS16 also sets out how we will work with NHS Camden to improve and protect health and also support the provision of new health facilities.
- 12.6 The following Core Strategy policies are also relevant as they work together to promote health and improve well-being:
- CS8 - *Promoting a successful and inclusive Camden economy,*
 - CS10 - *Supporting community facilities and services,* and
 - CS17 - *Making Camden a safer place.*
- 12.7 The following policies of the Camden Development Policies are also relevant:
- DP15 - *Community and leisure uses;*
 - DP26 - *Managing the impact of development on occupiers and neighbours;* and
 - DP32 - *Air quality and Camden's Clear Zone.*

Creating healthy communities

- 12.8 Where possible developments should:
- Encourage walking and cycling;
 - Discourage car use to reduce emissions and accidents;

- Provide landscaping, planting and trees to improve air quality and quality of life;
- Provide adequate amenity space for visual and physical recreation;
- Ensure a mix of uses within or near the residential area to reduce the need to travel; and
- Improve the environmental quality of buildings to ensure buildings stay warm in winter and cool in summer.

The NHS Camden Health Checklist for Planning

- 12.9 This guidance is designed to complement policy 3.2 of the London Plan which requires Health Impact Assessments for major developments, and consideration of the health impacts of development to ensure major new development promotes public health within our borough.
- 12.10 The NHS Camden health checklist for planning has been developed to ensure that health is a key consideration within new developments. The checklist provides support and guidance for developers in order to maximise the health benefits of any scheme. The NHS Camden Health Checklist for Planning is contained in Appendix 1 of this section.
- 12.11 We will require a completed health checklist to be supplied alongside all applications for all developments which meet the following criteria:
- More than 10 residential units, including changes use and new dwellings
 - More than 1,000sq m of non-residential floor space
 - Loss/gain of D1 floorspace of more than 50sq m

Hot food takeaways (A5 uses)

- 12.12 The document *Healthy Weight, Healthy Lives: A Cross Government Strategy for England*, published by the government in January 2008 highlights the commitment to promoting healthier communities. A key element of this strategy is the promotion of healthier food choices. The document highlights the need for local authorities to manage the proliferation of fast food outlets as a means of combating their known adverse impact on community health.
- 12.13 Core Strategy policy CS7 and policy DP12 of the Camden Development Policies, along with Camden Planning Guidance 5 - Town Centres, Retail and Employment aim to manage the number and concentration of food, drink and entertainment uses, including hot food takeaways. The measures we use include:
- limiting the number of A5 units in centres and rows of shops (frontages);
 - preventing consecutive takeaway shops opening next to one another;
 - only allowing new A5 uses in appropriate locations where their impact can be minimised; and

- using legal obligations to ensure that impacts are controlled e.g. opening hours.

12.14 Please see section 5 on town centres, retail and entertainment uses in Camden Planning Guidance 5.

Assessing the requirement for new health facilities

12.15 Health facilities include hospital and other premises that provide health and medical services such as doctors, integrated care centres, polyclinics and dentists. Camden Core Strategy policy CS10 aims to ensure that sufficient community facilities (including health facilities) are provided to meet the needs of Camden's population. Policy CS16 specifically aims to ensure that there is adequate provision of health facilities in partnership with NHS Camden.

12.16 Part e) of CS10 expects development that increases the demand for community facilities and services to make appropriate contributions towards providing new facilities or improving existing facilities. These contributions could be financial or they could involve the direct (re)provision of health facilities within or near a proposed development site.

12.17 The Council will consult with NHS Camden to assess the appropriate level and type of contribution required to mitigate any health care impacts which might be generated by a development proposal. The Council will also have regard to the model commissioned by the Healthy Urban Development Unit (HUDU), updated October 2009. The model is designed to forecast the level of demand for health facilities that might result from a new development and the subsequent cost of provision. Large, strategic schemes will be expected to assess the impact of visitors and employees in addition to the new and existing resident population. In other cases, contributions will not normally be sought for developments of less than 10 residential units.

12.18 Please see Camden Planning Guidance 8 – *Planning obligations* for our detailed approach.

Further information

PPS1	PPS1 - Delivering Sustainable Development indicates that LDF policies should plan to protect human health and address accessibility for all members of the community to a range of facilities including health, leisure and community services. It also states that LDF documents should deliver safe, healthy and attractive places to live and support the promotion of health and wellbeing by making provision for physical activity.
PPS23	PPS 23 - Planning and Pollution Control states that potential health impacts arising from development can be a material consideration.
The London Plan	The London Plan (consolidated since 2004) published in 2008 recognises health as a key cross-cutting objective of the overall strategy. The Plan also contains the following relevant policies: <ul style="list-style-type: none"> • Policy 3A.20 Locations for health care • Policy 3A.21 Health objectives • Policy 3A.22 Medical excellence
Mayor's Guidance	<ul style="list-style-type: none"> • Health Issues in Planning: Best Practice Guidance (June 2007) – explains how planning decisions can directly and indirectly improve health and reduce health inequalities through a number of topics, e.g. housing, transport, employment and skills, education etc. • Sustainable design and Construction (May 2006) – recommends a number of building specific measures to benefit the health of occupants, e.g. improving internal air quality, ensuring sufficient levels of natural light etc.
CABE	Commission for Architecture and the Built Environment. (2009). Future health: sustainable places for health and wellbeing.
Key determinants of health	Search on the London Health Observatory: www.lho.org.uk
Healthy Urban Development Unit	Guidance on linking planning and health: www.healthyurbandevlopment.nhs.uk/pages/key_docs/key_documents_hudu.html

Appendix 1: NHS Camden health checklist for planning

Issue to address	Included in proposal/development	Provide details (Evidence from proposals)	Further action required	Relevant LDF policies
1.0 HEALTHCARE FACILITIES AND SERVICES				
1.1 Will the development increase demand on existing primary and secondary care health services?	<input type="checkbox"/> Yes <input type="checkbox"/> No (if no, please indicate what further action will be required)			Core strategy policy CS16
2.0 PHYSICAL ACTIVITY				
2.1 Do the proposals maximise physical activity opportunities? (Active travel; leisure facilities; access to green and open spaces; HomeZones; schools; business; Olympics etc)	<input type="checkbox"/> Yes <input type="checkbox"/> No (if no, please indicate what further action will be required)			Core Strategy policies, CS11, CS15, CS16 and Development Policies DP15, DP17, DP31
3.0 CRIME AND COMMUNITY SAFETY				
3.1 Have measures been taken to ensure that the proposals will not have a negative impact on crime and community safety? (Licensed premises; drugs & alcohol; road traffic injuries; etc.)	<input type="checkbox"/> Yes <input type="checkbox"/> No (if no, please indicate what further action will be required)			Core Strategy policy CS17
4.0 HOUSING				
4.1 Do the proposals include housing which is: affordable, in mixed use developments; mixed tenure (private, affordable, social); different sizes, accessible and suitable for all ages.	<input type="checkbox"/> Yes <input type="checkbox"/> No (if no, please indicate what further action will be required)			Core Strategy policy CS6 and Development Policies DP1-9
5.0 EMPLOYMENT AND TRAINING				
5.1 Do the proposals provide employment and training opportunities for local people?	<input type="checkbox"/> Yes <input type="checkbox"/> No (if no, please indicate what further action will be required)			Core Strategy policy CS8 and Development Policy DP13
6.0 EDUCATION				
6.1 If education facilities are provided, will they be designed to include wider community use and include green and open space?	<input type="checkbox"/> Yes <input type="checkbox"/> No (if no, please indicate what further action will be required)			Core Strategy policy CS10
7.0 NEIGHBOURHOOD AND BUILDING DESIGN				
7.1 Do the proposals include: accessible street designs for older people and people with mobility problems; and gardens allotments or play areas?	<input type="checkbox"/> Yes <input type="checkbox"/> No (if no, please indicate what further action will be required)			Core Strategy policies CS14 and CS15
7.2 Do proposals ensure that buildings are designed to maximise physical activity (positioning of stairwells, shower rooms, secure cycle parking etc)	<input type="checkbox"/> Yes <input type="checkbox"/> No (if no, please indicate what further action will be required)			Core Strategy policies CS11, CS16 and Development Policies DP6, DP17, DP24
8.0 CLIMATE CHANGE AND SUSTAINABILITY				
8.1 Do the proposals mitigate against a negative impact on the environment (noise & air quality; renewable energy; contaminated land; waste management etc.)	<input type="checkbox"/> Yes <input type="checkbox"/> No (if no, please indicate what further action will be required)			Core Strategy Policy CS13 and Development Policy DP22
9.0 FOOD				
9.1 Do the proposals include provision of affordable and nutritious food outlets, food growing and limit the proliferation of fast-food outlets?	<input type="checkbox"/> Yes <input type="checkbox"/> No (if no, please indicate what further action will be required)			CS16
10.0 WIDER ASSESSMENT				
10.1 Have the health impacts been considered as part of any other assessment? (SEA, HIA, IIA, EIA etc)	<input type="checkbox"/> Yes <input type="checkbox"/> No (if no, please indicate what further action will be required)			n/a

Index

Access (disabled).....	45	Micro-climate . See Wind and micro-climate	
Air quality.....	7	Noise and vibration.....	19
Allotments.....	62	Open space	59
Construction management plans	39	Overlooking.....	37
Contaminated land	15	Play Space.....	61
Daylight and sunlight.....	31	Privacy	See Overlooking
Green spaces	62	Right to light.....	35
Healthy communities	79	sport and recreation facilities.....	59
Hot food takeaways.....	81	Wind and micro-climate	53
Lighting.....	25		

Strategic Planning and Information
London Borough of Camden
Town Hall Extension, Argyle Street
London WC1H 8EQ
Tel: 020 7974 2043 / 2519
Fax: 020 7974 1930
Email: ldf@camden.gov.uk
www.camden.gov.uk

Camden Planning Guidance

Transport

London Borough of Camden

CPG 7



CPG7 Transport

1	Introduction	5
2	Assessing transport capacity	7
3	Travel plans.....	13
4	Delivery and servicing management plans	21
5	Car free and car capped development.....	25
6	On-site car parking.....	29
7	Vehicle access	35
8	Streets and public spaces	41
9	Cycling facilities.....	47
10	Minicab offices	56

1 Introduction

What is Camden Planning Guidance?

- 1.1 We have prepared this Camden Planning Guidance to support the policies in our Local Development Framework (LDF). This guidance is therefore consistent with the Core Strategy and the Development Policies, and forms a Supplementary Planning Document (SPD) which is an additional “material consideration” in planning decisions. This new guidance will replace the Camden Planning Guidance 2006, updating advice where appropriate and providing new guidance on matters introduced or strengthened in the LDF.
- 1.2 The Camden Planning Guidance covers a range of topics (such as housing, sustainability, amenity and planning obligations) and so all of the sections should be read in conjunction, and within the context of Camden’s LDF.

Transport in Camden

- 1.3 Camden benefits from excellent transport provision with international and national rail links, numerous tube stations and a large number of bus routes providing accessibility within Camden, to the rest of London and beyond. However, being a located in central London, the borough also faces considerable transport challenges, including congestion and poor air quality.

What does this guidance cover?

- 1.4 This guidance provides information on all types of detailed transport issues within the borough and includes the following sections:
 1. Assessing transport capacity
 2. Travel Plans
 3. Delivery and Servicing Management Plans
 4. Car free and car capped development
 5. On-site car parking
 6. Vehicle access
 7. Streets and public spaces
 8. Cycling facilities
 9. Minicab offices
- 1.5 This guidance supports the following Local Development Framework policies:

Core Strategy

- CS11 Promoting sustainable and efficient travel
- CS16 Improving Camden’s health and well-being

Development Policies

- DP16 The transport implications of development
- DP17 Walking, cycling and public transport
- DP18 Parking standards and limiting the availability of car parking
- DP19 Managing the impact of parking
- DP20 Movement of goods and materials
- DP21 Development connecting to the highway network
- DP32 Air quality and Camden's clear zone

2 Assessing transport capacity

KEY MESSAGES

- A Transport Assessment is required for all schemes which will generate a significant travel demand
- Further guidance is contained within Transport assessment best practice guidance document, TfL 2006

- 2.1 This guidance aims to make sure that applicants submit all the information that is needed to determine a planning application in terms of the assessment of transport conditions before and after the development has taken place, and transport measures that will need to be secured before a development comes into use.
- 2.2 It relates to Camden Core Strategy policy CS11 - *Promoting sustainable and efficient travel* and policy DP16 - *The transport implications of development* of the Camden Development Policies.



When does this apply?

- 2.3 This guidance applies to planning applications that involve a change in the way that a site is accessed from the highway, and planning applications that will alter how people or goods are moved, how many trips they make, and when the trips take place.
- 2.4 Reference should be made to Transport for London's guidance document 'Transport assessment best practice' for more detailed guidance, along with section 2 of this guidance, relating to Travel Plans. In line with policy DP16 of the Camden Development Policies document, where the transport implications of proposals are significant we will

require a Transport Assessment to examine the impact on transport movements arising from the development.

How should Transport Assessments be prepared?

The requirement for a formal Transport Assessment

- 2.5 Appendix 1 of the Camden Development Policies document provides guidance on the scale of development that is likely to generate a significant travel demand and therefore require either a transport assessment or a transport statement. The use class and floorspace relationships in Appendix 1 are simply guidelines, and have been selected on the basis that their travel characteristics are likely to have a significant impact on travel. The Council will require submission of a Transport Assessment for a development likely to have any of the following travel characteristics (having regard to any existing travel generated by activity on the development site):
- a) More than 1,000 person trips per day; or
 - b) More than 100 person trips during the morning or evening peak (0700-1000 or 1600-1900); or
 - c) More than 500 vehicle movements per day; or
 - d) More than 100 vehicle movements in any single hour; or
 - e) More than 20 heavy goods vehicles (over 7½ tonnes) per day; or
 - f) Any heavy goods vehicle movements between midnight and 6am.
- 2.6 Although a formal Transport Assessment is not required for schemes that do not have any of these travel characteristics, where there is any material change to travel patterns, information will still need to be submitted as part of the standard development control process, indicating the amount of travel that will arise, and when and how it will be accommodated (see paragraph 2.12).

Information required as part of a Transport Assessment

- 2.7 At an early stage, applicants should discuss with the Council the scope of the Transport Assessment, and the most appropriate methods to use (e.g. data sources, estimation of trips generation, modelling requirements). The level of information contained within the Transport Assessment should relate in scale and kind to the particular development.
- 2.8 A Transport Assessment should generally include the following information. Please note that this table is a summary of the information contained within Transport assessment best practice guidance document, TfL 2006 and so reference should be to this TfL guidance.

Figure 1. Transport Assessment Requirements

TA1. Description of development	
a) Detailed site plan (min. 1:1250).	Always required.
b) Schedule of floor areas of existing uses on the site.	Always required.
c) Schedule of floor areas of proposed uses on the site.	Always required.
TA2. Description of base networks	
a) Plan showing relationship of site to the surrounding road, public transport, pedestrian and cycle networks. Include any tram routes or proposals.	Study area and base networks to be agreed with the Council.
b) Information on traffic flows, accident records, on-street parking conditions, and identify any critical links and junctions.	For proposals increasing motor vehicle movements, criteria C to D.
c) Information on frequency, reliability and capacity of bus, tram, underground and rail services within the study area.	For proposals increasing trips and trip concentrations, criteria A and B.
TA3. Trip generation	
a) Number of person trips generated by mode and time of day.	Always required.
b) Number and size of vehicles required to service the building.	Always required.
TA4. Trip assignment	
a) Assignment of vehicular trips to the road network.	For proposals increasing motor vehicle movements, criteria C to D
b) Assignment of public transport trips to the bus and rail networks.	For proposals increasing trips and trip concentrations, criteria A and B.
c) Justification for assignment methodology.	Always required.
TA5. Vehicular access and circulation	
a) Analysis of junction design for access and egress, using appropriate packages if necessary (such as PICADY, OSCADY, LINSIG and TRANSYT).	Always required where a new access is provided or where an existing access will be more intensively used.
b) Describe the arrangements for servicing and access for emergency vehicles.	Always required.
c) Describe the number, allocation and design of on-site parking and compare this with Council standards.	Always required.
TA6. Pedestrians and cyclists	
a) Assess the capacity and safety of existing pedestrian and cycle facilities and describe how they are affected by the development.	Always required.
b) Describe the number, allocation and design of on-site cycle parking and compare this with Council standards.	Always required.
c) Describe design features on or outside the site to assist pedestrians and cyclists.	Always required.
TA7. Public transport	
a) Assess the accessibility of the site by public transport.	Always required.
b) Identify BR and Underground stations and lines, tram routes or proposed tram routes, and bus services that will be significantly affected by the development. Evaluate and quantify impact of additional demand on capacity.	For proposals increasing trips and trip concentrations, criteria A and B.
c) Assess and quantify impact of additional road traffic on bus and tram reliability.	For proposals increasing motor vehicle movements, criteria C to D.
TA8. Road network	
a) Identify junctions and links that will be affected by development traffic. Quantify and evaluate the reserve capacity, queues and delays at critical junctions.	For proposals increasing motor vehicle movements, criteria C to D
b) Carry out a Safety Audit.	Only required where physical changes are proposed on the public highway.
TA9. People with a transport disadvantage	
a) Identify measures to make the site accessible to people with a transport disadvantage, including access for community transport services, the provision of designated car parking, drop-off points, shopmobility and scootability schemes (loan of scooters or electric wheelchairs to assist movement in the area around a home or destination from the initial point of arrival), and physical design features.	Always required.
TA10. Environmental impact	
a) The impact of generated traffic on air pollution and noise (unless included in an Environmental Assessment).	For proposals increasing motor vehicle movements, criteria C to D.
TA11. Conclusions and recommendations	
a) Summary of transport impacts.	Always required.
b) Details of remedial measures proposed to alleviate any identified problems or evidence provided that no remedial measures are necessary. In most cases, these will include outline provisions of a Transport Plan.	Always required.

- 2.9 The Regent's Canal in Camden has a transport function for walking and cycling and to a lesser extent for movement of passengers and freight by water. In addition to considering the highway and public transport networks detailed above, where a development is adjacent to the Canal, or the Canal forms a part of the pedestrian and cycle network close to a development, the Transport Assessment should consider how the development may affect travel on and alongside the Canal. Policy DP20 of the Camden Development Policies deals specifically with the use of the Regent's Canal for moving goods and materials.

What should the Transport Assessment achieve?

- 2.10 Where an Assessment is submitted, it should enable the Council to consider whether:
- the development is acceptable in its proposed form and without any alterations to existing transport arrangements;
 - some alteration would be needed to the development or to transport facilities or networks in order to accommodate the travel it would generate in an acceptable way;
 - the development could not proceed without unavoidable harm to travel or the transport system, in which case the proposal will be contrary to LDF policy DP16, and will be refused by the Council if it is not withdrawn.
- 2.11 If the Assessment shows that amendments are needed, it should recommend specific amendments and mechanisms to ensure that these amendments take place in the event of the development being implemented. Recommendations might include:
- conditions to prevent implementation prior to the completion of planned transport provision with secured funding;
 - conditions to ensure that implementation is in phases, such that each phase follows completion of any necessary planned transport provision with secured funding;
 - a legal agreement to ensure submission and implementation of:
 - a travel plan to manage travel demand;
 - a servicing plan to manage on- and off-site servicing arrangements following completion;
 - a construction management plan for the period from commencement to full operational occupation of the development to manage on- and off-site construction traffic, delivery and removal of materials, and any temporary changes to other traffic movements (including pedestrian and cyclist movements) in and around the site;
 - changed on-site arrangements for pedestrians, cyclists, cycles or motor vehicles (including public transport) through substitution of drawings showing amended facilities for movement, picking-up and

setting-down, parking, storage, queuing, loading and unloading, and/or employee lockers and showers;

- changed off-site arrangements for pedestrians, cyclists, cycles or motor vehicles (including public transport) through a legal agreement to ensure funding and implementation of amended or new facilities for movement, picking-up and setting-down, parking, queuing, loading and unloading, and/ or other measures such as public transport services, shelters, information and signage, city car clubs and city car schemes.

Developments below the threshold for Transport Assessment

- 2.12 Development Policy DP16 states that larger developments that would have implications for transport, but which fall below the threshold for a full transport assessment, will still be required to submit information regarding the transport implications of that scheme. Appendix 1 of the Development Policies document provides guideline floorspace thresholds for these types of developments. The type of information required is set out in DP16 and could be submitted as part of a Design and Access Statement.

Further information

Draft Guidance on Transport Assessment, Department for Communities and Local Government/ Department for Transport, August 2006 - this can be viewed on the consultation papers pages in the roads and vehicles section of: www.dft.gov.uk

Transport assessment best practice guidance document, Transport for London, May 2006 – this can be obtained via TfL at: 0845 305 1234

3 Travel plans

KEY MESSAGES

- Travel Plans enable a development to proceed without adverse impact on the transport system
- The requirements of a Travel Plan will be tailored to the specific characteristics of the site and the development

3.1 This guidance explains the circumstances under which travel plans are sought, what they are intended to achieve, how they should be prepared, and what measures should be considered for inclusion. In addition to general guidance for travel plans, this section provides guidance on:

- Workplace travel plans;
- School travel plans;
- Residential travel plans;
- Visitor management plans; and
- Leisure and event travel plans.

3.2 It relates to paragraph 11.16 of Core Strategy policy CS11 - *Promoting sustainable and efficient travel* and policies DP16 to DP21 of the Camden Development Policies.



When does this apply?

3.3 This guidance applies to all planning applications that involve a significant impact on travel or the transport system. It will also guide consideration of Travel Plans submitted where the impacts are less, but where the transport provision does not have capacity for increased demand, and where demand management measures are desirable to

address sustainability concerns. Transport for London recommends that a Travel Plan be submitted for any residential development of over 30 units. Various uses may not fall into these categories (e.g. religious institutions), but we will seek Travel Plans where appropriate and requirements will be tailored to the characteristics of the site and the development.

- 3.4 Reference should be made to Transport for London's documents 'Guidance for workplace travel planning for development' (TfL, 2008) and 'Guidance for residential travel planning in London' (TfL, 2008) for more detailed guidance. Reference should also be made to planning guidance about Transport assessments. In line with Development Policy DP16, the Council will also require a Transport Assessment to be submitted in support of any development that significantly increases travel demand or would have a significant impact on travel or the transport system.

General guidance

- 3.5 Travel Plans are one way in which developments can contribute to meeting targets on traffic reduction and improving air quality. A Travel Plan is a package of measures, generally developed by employers or property managers, which is designed to reduce car use and promote greener forms of transport. Travel Plans will often be a mechanism that arises from a Transport Assessment as a means of enabling a development to proceed without adverse impact on the transport system. The Council, Transport for London, and partners in the North and Central Travel-plan Network can provide advice and assistance in the creation of Travel Plans by organisations that are existing, new, relocating or expanding, including hospitals, schools, and businesses organisations.
- 3.6 Where a Travel Plan is necessary in terms of policy DP16 or because elements of the transport system have no additional capacity, submissions in connection will generally be secured by S106 agreement. This is because the applicant will rarely be the final occupier of the scheme, and furthermore a Travel Plan will require ongoing development subsequent to the initial occupation. Travel Plans will require monitoring on at least an annual basis, and the Council will usually require submission of a monitoring report.
- 3.7 Travel Plans are developed over time, with a typical 3-year target being a specified reduction in the number of motor vehicle trips. This means promoting and increasing cycling, walking, and the use of public transport so that a real choice may be made between all travel methods. It is the enthusiasm and commitment of the organisation in putting the theories into action that ensures a Plan's success. Key to this is the support of senior management in the development of a Travel Plan. If the development does not replace an existing use, the Council will advise on the appropriate modal split targets.

Workplace travel plans

- 3.8 A workplace travel plan will usually contain measures geared particularly to promoting alternatives to single-occupancy car use. A workplace travel plan will be specific to each individual site and the nature of the business activity there. Workplace travel plans are potentially suitable for any organisation that generates a significant number of employee trips including offices, hospitals, distribution centres, large shops and supermarkets, cinemas and theatres, primary care centres and GP surgeries. Specific guidance is available on school travel plans where the travel of pupils needs to be considered.
- 3.9 As a minimum, a workplace travel plan should address travel by staff to and from work and on business. However, a travel plan may also address visitor, client and customer travel, suppliers making deliveries, contractors undertaking work on site and fleet procurement/management.
- 3.10 The key components necessary for all workplace travel plans are:
- corporate/management support and commitment;
 - designated travel co-ordinator;
 - consultation on the plan;
 - staff travel surveys - baseline & monitoring;
 - targets – challenging but achievable;
 - promotion of the package to the workforce;
 - monitoring – on-going, to check and maintain progress and development.
- 3.11 Detailed measures will include some or all of the following:
- restricted availability of workplace car parking, and introduction of charges;
 - a communication strategy detailing how sustainable transport and travel plan issues will be promoted to staff and visitors;
 - easily available in-house public transport information for all staff at the workplace and for visitors, including leaflets and maps, intranet and internet;
 - public transport promotion and initiatives including interest-free season ticket/ travelcard loans, and mutual beneficial links with public transport operators to increase ridership and improve the services convenient for the workplace;
 - promotion of car-sharing where walking, cycling and public transport is not an option;
 - cycle prioritisation and provision of secure and convenient facilities such as: well-lit, workplace parking; lockers; showers and changing rooms;
 - procurement of a cycle repair and servicing facility (possibly through external tender process);

- financial benefits for cyclists such as mileage allowances for work-related journeys, 0% loans and salary sacrifice initiatives for purchase of bikes and equipment, assistance with cycle insurance;
- replacement of company cars with more sustainable benefits, adjusted car allowances and loans to discourage car use and release resources for greener options;
- on-site charging for electric bikes and vehicles;
- reduction of vehicle emissions through policies such as regular emissions testing;
- scheduled replacement of any existing fleet or pool vehicles with pool bikes and other pool vehicles that use cleaner fuels;
- travel reduction initiatives – for example, increased working from home, teleworking and teleconferencing can reduce the number of employee trips to the workplace;
- walking encouragement and provision of information on the best routes to and from the workplace for commuting, working and leisure, for staff and for visitors.

School travel plans

3.12 A school travel plan (STP) can bring benefits of safer and more sustainable transport for the whole community. Each STP will need must be designed to take into account and be tailored to local circumstances. Where a school has strong links with other schools in the area, consideration should be given to developing a joint STP. An STP can potentially result in:

- Less cars and congestion around the school;
- Healthier, more active pupils, families;
- Less pollution around the school;
- Safer walking and cycling routes around the school;
- Improved school grounds with provision for bicycle storage;
- A more accessible school site; and
- Improved attendance and achievement.

3.13 All STPs have to be sent to Camden and to Transport for London for approval. It is essential that an STP complies with the Transport for London criteria used to assess STPs. It must also be signed and approved the school's Headteacher and the Chair before submission. These criteria for assessing STPs are detailed in the TfL publication 'What a school travel plan should contain'.

Residential travel plans

3.14 A residential travel plans provide a key mechanism for ensuring that sustainable access is an integral feature of a development. Each one should form a holistic package of measures integrated into the design, marketing and occupation of the site rather than 'retrofitted' once the

development is established. A residential travel plan provides a mechanism for setting out how the various parties (including the developer and future occupiers) can work together in partnership to encourage sustainable travel patterns.

- 3.15 Residential travel plans are concerned with journeys made from a single origin (home) to multiple and changing destinations. Each residential travel plan is site specific, with detailed measures partly determined by site opportunities and constraints such as the location of existing public transport routes, health facilities and workplaces in the immediate area. A residential travel plan should include parking restraint, and should support walking, cycling and public transport use. A residential travel plan should include both hard measures, such as site-design, provision of infrastructure and new services, and soft measures such as marketing, promotion and awareness-raising among residents. A S106 agreement securing a residential travel plan will also need to require that all future residents are informed of the existence of the travel plan and any restrictions it implies (for example, lack of access to parking permits in controlled zones).
- 3.16 The main objectives of a residential travel plan are to:
- address residents' need for access to a full range of facilities for work, education, health, leisure, recreation and shopping. In some cases this will mean providing facilities that reduce the need to travel, such as a local shop;
 - reduce the traffic generated by the development to a significantly lower level of car trips than would be predicted for the site without the implementation of the travel plan;
 - promote healthy lifestyles and sustainable, vibrant local communities;
 - encourage good urban design principles that open up the permeability of the development for walking and cycling linked to the design and access statements;
 - address specific problems identified in the site's Transport Assessment - for example, a road safety problem that prevents children or older people from gaining access to key facilities.
- 3.17 There are two distinct phases in development of a residential development plan:
- 3.18 Stage 1 should cover design, construction, occupation, and the first monitoring and review period. Preparation and implementation will initially rest with the developer or a consultant appointed by the developer, however implementation may involve a steering group which has representation from different agencies such as the local authority, public transport operators and residents (once they are in occupation). At this stage, the developer, the manager of the development, and the person designated as travel plan coordinator will have to be closely involved in managing and refining the travel plan. This period is crucial in terms of ensuring that the measures outlined in the plan are actively

implemented as part of the development and that the objectives and targets identified in the plan have potential to be met.

- 3.19 Stage 2 will be after full occupation of the development and completion of all measures to integrate the development with the surrounding area. Responsibility for managing and developing the travel plan will generally need to be passed on, and measures put in place to ensure that implementation of the plan continues.
- 3.20 It is important that an effective management structure is put in place to enable the overarching responsibility for the plan to be passed from the developer to the residents or to a residents' management company or to another body such as the Council. The manager will need to be able to ensure the continuation of travel plan measures such as car clubs, car share schemes. A residential travel plan will therefore need to specify its own management structures, which should generally have the following characteristics:
- identifying the developer as the party responsible for delivering the travel plan and for initial implementation, including responsibility for achieving the targets and objectives established in the travel plan. The plan should specify clearly at what point the developer can pass on responsibility for the plan wholly to residents, a management committee, or similar. Up to that time, steering groups and other management structures may assist in implementing the travel plan, provided that the developer retains ultimate responsibility;
 - establishing the ongoing management committee or group with a clear purpose, accountability and ability to take action – this is most likely to be achieved by developing a constitution for the group;
 - providing funding to ensure ongoing administrative support for the group once established and adequate resources to carry out continuing travel plan measures

Visitor management plan

- 3.21 Where developments are likely to involve visitors arriving and leaving in taxis and coaches, submitted proposals should show how these can be accommodated without harm, and a Visitor Management Plan may be required to where it is necessary to impose controls on the types of vehicle, the times of arrival, and the specified picking-up and setting-down points.

Leisure and event travel plan

- 3.22 Event travel plans are designed for short-term events (either regular or one-off) and as such will be implemented differently to workplace travel plans. The general structure of the plan will be similar but the content of each section will be different when dealing with events.

3.23 An event travel plan should contain the following:

- Background information - providing an overview of the event and its organisers and including information on any existing environmental policy, why a travel plan is being produced and detailing the location of the event along with some information on the site's accessibility.
- Site audit and survey - providing the information to inform the rest of the travel plan. The site audit provides details on how accessible the site is by various forms of transport and includes both on-site and off-site infrastructure.
- Aims and objectives - broad statements of intent regarding what it is hoped the travel plan will achieve.
- Targets - There are two types of target that can be set for a travel plan. The first is known as an 'aim-type' target and is generally based on the percentage share of each travel mode used, and the other type of target that is set is the 'action-type' target which sets a deadline for a certain action to have taken place.
- Measures - detailing the various incentives and initiatives that can be employed to achieve the targets set in the previous section. The measures that are implemented will depend on various factors including the results of the surveys, the size of the event (area or number of visitors), the site audit and the amount of funding available.
- Monitoring Strategy and Management Structure – in order to record the overall success of the travel plan as well as how effective individual measures have been.
- Action Plan – providing a summary of how the travel plan will be implemented and monitored. An action plan typically lists the measures that are due to be implemented along with details on who is responsible, when they are to be undertaken, how the success will be gauged and which aims and objectives they relate to.

Further information

Government resources related to travel plans can be viewed in the sustainable travel section of: www.dft.gov.uk

Residential and employment travel plans best practice guidance documents, Transport for London, forthcoming 2006-07 – when published these will be available from TfL at: 0845 305 1234

What a school travel plan should contain, Transport for London - this can be viewed on the Camden Schools/ School Travel Plans/ Success Factors pages in the education section of Camden's website - www.camden.gov.uk/ccm/navigation/education/camden-schools/school-travel-plans/success-factors/

4 Delivery and servicing management plans

KEY MESSAGES

- Transport Assessments represent the best tool to consider how a development can most appropriately be serviced
- Developments should accord with the Servicing Guidelines provided in this guidance

- 4.1 The purpose of this guidance is to give details on how Delivery and Servicing Management Plans can be used to manage and mitigate the potential impacts of deliveries and servicing on the amenity of occupiers and neighbours.
- 4.2 This guidance relates to Core Strategy Policy CS5 - *Managing the impact of growth and development* and policies DP20 - *Movement of goods and materials*, and DP26 - *Managing the impact of development on occupiers and neighbours* of the Camden Development Policies

When does this guidance apply?

- 4.3 This guidance applies to all development proposals which are likely to generate delivery and servicing movement and therefore may incur significant noise and disturbance impacts. Further details on the circumstances in which the Council will expect/require Delivery and Servicing Management Plans are set out within this guidance.

How should Delivery and Servicing Management Plans be prepared?

Service vehicles and waste collection

- 4.4 General guidance on requirements for service vehicles and goods vehicles is given in Development Policy DP20 - *Movement of goods and materials*. Transport Assessments represent the best tool to consider how a development can most appropriately be serviced. Loading and unloading for some developments can safely and appropriately take place on-street, depending on the nature of the street and the development. Where a development is most appropriately serviced off-street, the application should show that the development will accord with the servicing guidelines shown in the table at the end of this section.
- 4.5 Guideline thresholds for the scale of development where a Transport Assessment will be required are given in LDF Development Policies Appendix 1. For development of significant floorspace in commercial use and residential institutions, the LDF proposes off-site bays for servicing, but also proposes a Transport Assessment that can test the appropriateness of alternative solutions.

- 4.6 For retail-type floorspace (Use Classes A1-A5), the guideline threshold is developments of 1,000 sq m or more. For other commercial floorspace, hotels, and institutional residential accommodation such as hotels, colleges and hostels, the guideline threshold is developments of 2,500 sq m or more. The transport characteristics of Use Classes D1-D2 (including surgeries, places of worship and cinemas) are too variable for any assumption to be made about the need for on-site servicing, but a Transport Assessment is sought in most cases.
- 4.7 The scale of a development is not the only factor controlling the servicing needs it generates. A Transport Assessment is required for any development that would significantly impact the transport system under policy DP16 of the Camden Development Policies. This could be expected to include, for example, any development serviced on-street and likely to receive more than 10 deliveries a day or 2 deliveries an hour. Assessment is also required for developments that generate a number of heavy vehicle movements (see the Assessing Transport Capacity section of this guidance).
- 4.8 If waste collection vehicles need to access a development site, this can be a key consideration in the design of motor vehicle access and circulation spaces. Information on the amount of space needed for sorting and storage of waste on-site prior to collection is given in the Waste recycling and storage section of CPG1 Design. The Council does not generally allow waste to be left on the highway for collection on a specified day except in the case of residential development of 6 dwellings or less.
- 4.9 External storage space for large waste containers is sought for residential development of 7 dwellings or more, and for most non-residential development. The external storage space should be at or near street level, and within 10 metres of a place suitable for a collection vehicle to stop. If appropriate external storage space for waste cannot be provided within 10 metres of the public highway, it will generally be necessary for the collection vehicle to access the development site. In this case, circulation spaces will need to be considered in the same way as those for service vehicles.

Servicing Guidelines

Swept paths	Applicants should provide evidence of swept paths on submitted drawings.
Turning areas	Normally, all vehicles must be able to enter and leave the site in a forward facing direction. If in exceptional cases this is not possible, the service area must be designed to enable vehicles to reverse off the highway rather than onto it.
Demarcation	Servicing bays and turning areas should be clearly marked out, for example, by the use of different colours and materials, to discourage their misuse for car parking and storage.
Pedestrians	Care must be taken to provide safe segregated routes for use by pedestrians. Where access roads for service vehicles represent the most direct or visible route for pedestrians, a segregated footway at least 1.8 m in width should be provided with direct links to each pedestrian entrance of each building on site.
Access roads	A minimum carriageway-width of 6.0 m is required where an internal access is designed for two-way use by service vehicles. Where a footway is not provided to each side, a safety margin with a minimum width of 0.5m must be provided wherever there is no footway.
Headroom	A vertical clearance of 3.5m must be provided for light and medium goods vehicles.

Further information

CPG1 Design, LB Camden 2011

Camden Streetscape Design Manual, LB Camden 2005

Camden Council transport strategies and plans, including the Streetscape Design Manual, can be viewed in the transport and streets section of the Council's website

Residential roads and footpaths: layout considerations - Design bulletin 32 (2nd edition), HMSO 1992 – this can be obtained via:

www.tsoshop.co.uk/bookstore.asp

5 Car free and car capped development

KEY MESSAGES

- We expect car free development in the borough's most accessible locations and where a development could lead to on-street parking problems
- Legal agreements will be used to maintain car-free and car-capped development over the lifetime of a scheme

- 5.1 This section explains further the terms car-free and car-capped development, as referred to in the Camden Core Strategy and Camden Development Policies, the mechanisms that are needed to secure them, and the circumstances in which it will be appropriate for the Council to refuse additional dwellings that are not car free or car capped.
- 5.2 It relates to Core Strategy Policy CS7 – *Promoting sustainable and efficient travel* and policies DP18 – *Parking standards and limiting the availability of parking* and DP19 - *Managing the impact of parking* of the Camden Development Policies.

Car-free development

A development which has no parking within the site and occupiers are not issued with on-street parking permits

Car-capped development

A development which has a limited amount of on-site car parking, but no access to on-street parking permits.

- 5.3 Car-free and car capped development is successful in Camden because most of the borough has very good access to public transport services. Levels of car ownership are low compared with London generally, and choosing not to own a car can be an attractive lifestyle option. The guidance in this section covers:
- What car free development is, and where it is sought;
 - What car capped development is, and where it is sought;
 - Implementation of off-street parking restrictions for car-free and car-capped development, including partial provision of car free and car capped development, and maintaining the on-street parking rights of existing occupiers;
 - Meeting the parking needs of disabled people.

When we expect car free and car capped housing

- 5.4 Car free and car capped requirements apply to developments in particular locations and circumstances:
- we expect car free development in the Central London area, our town centres and other areas with high public transport accessibility (see Development Policy DP18);

- we will also expect car free development where the creation of a new access could lead to on-street parking problems where the loss of kerb space creates unacceptable parking pressure. Refer to Development Policy DP21, and the Access section of this guidance for more information);
 - Car capped development applies to schemes that would have an unacceptable impact on on-street parking conditions or highway management and safety through the introduction of new units with access to on-street parking permits (see Development Policy DP19).
- 5.5 Car-free or car-capped housing may be sought wherever development involves the creation of one or more additional dwellings – whether newly built, or created by a conversion or change-of-use.
- 5.6 Non-residential development can potentially involve car-free or car-capped designation if it creates a new non-residential address or involves a change-of-use that would otherwise increase the demand for car parking. This reflects the operation of the parking permit scheme, where permits relate to individual addresses.

Car free development

- 5.7 Car-free development is development that does not have any car parking. No parking is provided or allowed on the site (except parking designated for disabled people), and all of the dwellings or units created are not entitled to on-street car parking permits. Where we seek car free development our parking standards do not apply as no parking is allowed.
- 5.8 Camden Development Policy DP18 states that we will expect development to be car free in the Central London Area, the town centres of Camden Town, Finchley Road/ Swiss Cottage, Kentish Town, Kilburn High Road and West Hampstead, and other highly accessible areas.
- 5.9 'Highly accessible areas' are considered to be areas with a public transport accessibility level (PTAL) of 4 and above. The PTAL of a specific site can be established using Transport for London's Planning Information Database website pages, which can be found at: <http://webpid.elgin.gov.uk/>.
- 5.10 Car free development will also be required where the creation of an access to allow off-street parking would reduce the availability of on-street parking (see also section 6 of this guidance on vehicle access), or would otherwise cause problems relating to highway management or safety. Policy DP19 of the Camden Development Policies states that we will resist developments that would harm on-street parking conditions or harm highway safety.

Car capped development

- 5.11 Car-capped development is development in which all of the dwellings or units created are not entitled to on-street car parking permits, although some or all of the dwellings or units created may have a parking space

on the site, in accordance Camden's parking standards (see policy DP18 and Appendix 2 of the Camden Development Policies). It therefore differs from car free development because some on-site car parking is allowed, in line with Camden's parking standards.

- 5.12 Car capped development is sought in developments that are not in the locations listed in paragraph 4.7 above, where additional off-street spaces can be accommodated within the development without harming highway or on-street parking conditions, but where additional on-street car parking is not considered acceptable.

Circumstances where additional on-street car parking is not acceptable

- 5.13 There are parts of the Borough where increasing competition for on-street parking through introducing additional premises with on-street parking rights is not acceptable. This is generally the case in the Central London Area, but also in many other areas where the parking spaces available cannot meet existing demand. This has implications for queuing and congestion, illegal parking, and highway safety. In these circumstances, if a developer will not enter into an agreement to designate the additional development as car-free or car-capped, planning permission will not be given.
- 5.14 In considering the ability of available on-street parking to accommodate the impact of additional development, we will have regard to the cumulative effect of proposals in the area, including unimplemented and partly implemented schemes already granted planning approval.
- 5.15 Our Parking and Enforcement Plan provides regularly updated permit data, which is used to establish levels of on-street parking pressure on each of the borough's roads. This information will be used when considering the acceptability of applications that would involve the potential allocation of additional on-street parking permits to the future occupiers of new development.

Implementation of on-street parking restrictions for car-free and car-capped development

- 5.16 The whole of Camden has controlled parking and, in principle, is appropriate for car-free or car-capped development. On most days, most parking spaces on residential streets are only available to people holding a parking permit issued by the Council. In Controlled Parking Zones we can restrict access to on-street car parking because we can control the issuing of parking permits.

Controlled Parking Zones

Designated areas in regulations control how parking may be used on different sections of the street and at different times.

- 5.17 In order to be able to maintain car-free and car-capped development over the lifetime of a scheme, the developer will be required to enter into

a legal agreement under Section 106 of the Town and Country Planning Act 1990 (as amended), which would permanently remove the entitlement to an on street parking permit for each home created:

- 5.18 The legal agreement requires the owner of the development to inform incoming occupiers that they are not eligible to obtain a parking permit for on-street parking, or to purchase a space in a Council-controlled car park. This part of the legal agreement stays on the local search in perpetuity so that any future purchaser of the property is informed that occupiers are not eligible for parking permits.

Maintaining on-street parking rights of existing occupiers

- 5.19 Existing parking rights can normally be retained on development sites, where it can be demonstrated that existing occupiers are to return to the address when it is completed. This is common where an existing dwelling or block is being extended or subdivided. It can also occur where a change-of-use brings a site or property into residential occupation.
- 5.20 If a development is to have new occupiers, existing parking rights will not apply, and the Council will apply its car-free / car-capped policies as set out in Development Policies DP18 and DP19.

Meeting the needs of disabled people

- 5.21 Car-free development and car-capped development should be designed taking into account the needs of disabled car users. Blue Badge holders are able to use parking spaces in Controlled Parking Zones without a parking permit. Minimum parking standards apply to parking for people with disabilities, and 1 parking space for people with disabilities is required per 10 general-purpose dwellings (see Appendix 2 of the Camden Development Policies document). In addition, where car-free and car-capped developments contain wheelchair housing, the Council will expect a parking space to be provided for each wheelchair dwelling. Where a resident in need of a reserved disabled parking space moves into a development with no off-street spaces, the Council will consider a request for a designated disabled space on-street in the same way whether the development is formally car-free or not.

Further information

- 5.22 In addition the guidance above regard should also be had to Camden's Parking and Enforcement Plan (2004), which provides further information on our approach to managing parking in the borough.

6 On-site car parking

KEY MESSAGES

This section includes detailed guidance on:

- Implementation of numerical car parking standards
- Dimensions and layout of spaces, including dedicated spaces for disabled people
- Underground and stacked parking
- Car clubs and pool cars
- Electric charging points

6.1 This section assists applicants for developments that will involve the provision of off-street parking spaces.

6.2 It relates to Core Strategy Policy CS11 - *Promoting sustainable and efficient travel* and policy DP18 - *Parking standards and limiting the availability of car parking*; and Appendix 2 Parking standards of the Camden Development Policies. It should be read in conjunction with section 6 of this guidance on vehicle access.

When does this apply?

6.3 This guidance applies to planning applications that involve creation of off-street parking spaces, in line with the standards set out in the Camden Development Policies. The parking requirements for emergency services, such as ambulance, fire and policing facilities, will be assessed on an individual basis, having regard to the specific operational needs of a particular use.

6.4 Applicants should first seek to minimise car use from their development, in accordance with Core Strategy Policy CS11 and policies DP16-DP20 of the Camden Development Policies. Alternative measures include:

- provision for walking, cycling and public transport;
- car-free development so that there is no need for parking; and
- car clubs and pool cars.

How should on-site car parking be provided?

6.5 Standards for the number of spaces required for car parking and servicing are given in Camden Development Policies Appendix 2.

6.6 Thresholds and standards are given as a gross floor area (GFA) relating to the development as a whole, and are not intended to be applied separately to individual units that form part of a larger development. Shared use of parking spaces and servicing bays between units will be encouraged where practical.

- 6.7 Where a development crosses a threshold, requirements apply to the entire floorspace, not only the floorspace above the threshold. For example, for hotels, the requirement for visitor parking spaces for people with disabilities is 1 space per 1,250 sq m from a threshold of 2,500 sq m (Development Policies Appendix 2). This means that no requirement applies to a hotel of 2,000 sq m, but for a hotel of 5,000 sq m, a requirement of 4 spaces for disabled visitors applies.
- 6.8 Paragraph 18.7 of Camden Development Policies addresses the provision of parking for employees with a need for “continuous access to a car for work purposes”, as part of the maximum standards for employment generating uses. For the removal of doubt, this refers to travel needs that cannot be met by walking, cycling or public transport, and relates to access during the working day, not commuting to and from work

Dimensions and layout of car parking spaces

- 6.9 Figure 2 below sets out our minimum standards for the dimensions and layout for off-street car parking spaces.

Figure 2. Dimensions and layout of car parking spaces

Off-street car parking space (standard)	2.4m wide by 4.8m deep.
Front Garden/Forecourt	5.0m wide by 6.0m deep.
Off-street car parking space for use by disabled people	3.3m wide by 4.8m deep.
Layout of car parking spaces for general use	<p>90° parking – aisles may be two-way The minimum aisle width between the ends of spaces is 6.0m</p> <p>60° parking – aisles must be one-way The minimum aisle width between the ends of spaces is 4.2m</p> <p>45° parking – aisles must be one-way The minimum aisle width between the ends of spaces is 3.6m</p>

- 6.10 Disabled parking should be in line with the Mayor’s Draft London Housing Design Guide SPG (July 2009), which states in paragraph 3.3.2 that “Each designated wheelchair accessible dwelling should have a car parking space 2.4m wide with a clear access way to one side of 1.2m wide”.
- 6.11 Dedicated car parking spaces for use by disabled people should be designated with appropriate markings and signs. These spaces should be located as close as possible to main pedestrian entrances and passenger lifts. There must be no obstruction – such as a raised kerb or

heavy doors - between the parking spaces and the entrance to the building. In considering the appropriateness of distances to the furthest facility served by a dedicated parking space, the following guidelines will be taken into account:

Uncovered route	Less than 50m
Covered route (unenclosed or part enclosed)	Less than 100m
Completely enclosed route (unaffected by bad weather)	Less than 200m

- 6.12 In addition to dedicated parking spaces, where premises are likely to attract visits by the public, vehicular setting down and picking up points suitable for use by disabled people should be available as close to main building entrances and passenger lifts as possible.

Underground and stacked parking

- 6.13 Because of the high cost of land in Camden, some developers are seeking to use more space-efficient forms of car parking, such as underground and 'stacked' parking.
- 6.14 Whilst the Council considers that such provision can be appropriate in some circumstances, it must not cause harm in terms of visual impact and safety. In particular, proposals for underground and stacked parking would need to satisfactorily address potential issues in relation to vehicles queuing/ waiting, and impact on the highway, congestion and safety as vehicles manoeuvre around the site, along with any archaeological implications.
- 6.15 As with any car parking provision, underground and stacked parking must meet Camden's parking standards.

Car clubs

- 6.16 Paragraphs 11.18 of the Camden Core Strategy and 18.14 and 18.15 of the Camden Development Policies encourage the provision of car club spaces as an alternative to the provision of private car spaces, in order to make private transport more sustainable.
- 6.17 We will seek publicly accessible spaces, where provision is made as part of development. This enables spaces to form part of a wider network, improving accessibility to spaces, benefitting the local community and reducing impact on the public highway (by avoiding the provision of additional on-street spaces).
- 6.18 Developers should provide spaces for a Camden-approved city car club operator. Please contact the Council for our full list of approved operators.
- 6.19 The Council's preference is for the provision of car club spaces for electric or low carbon vehicles.



Electric charging points

- 6.20 As part of our approach to making private transport more sustainable, the Council promotes the use of low emission vehicles, including through the provision of electric charging points (see Camden Core Strategy Policy CS11).
- 6.21 Electric charging points allow electric vehicles to charge up whilst parked, ready for the next journey, and are normally located in dedicated parking bays. Further information on electric charging points can be found at: <http://www.newride.org.uk/>
- 6.22 We will seek the provision of electric charging points as part of any car parking provision in new developments (policy DP18 of the Camden Development Policies). The emerging London Plan (policy 6.13 Parking) states that 1 in 5 new spaces provided in new developments should provide charging points.
- 6.23 The Council will promote provision of electric vehicle charging spaces as an alternative to any general car parking spaces, but particularly if the charging spaces will be for electric pool cars or electric car-club cars. We will encourage use of renewable energy to provide power for charging points.
- 6.24 Parking for low emission vehicles, pool cars and car clubs should be provided from within the general car parking allowed by Camden's parking standards. If they are provided in addition to general car parking spaces, they are unlikely to be effective in encouraging more sustainable means of transport, and to the Council's overall aim of reducing congestion in the Borough.

Further information

- 6.25 The creation of off-street parking spaces will often require the creation of a new vehicle access to a site. This section should therefore be read alongside section 6 of this guidance on Access to sites for motor vehicles, which sets out how proposals involving new means access are judged in terms of impact on the highway, safety and visibility for emerging vehicles.

6.26 Other useful sources of information include:

- Mayor’s draft Housing SPG, which contains detailed guidance on the levels of car parking;
- Manual for streets; DfT; 2007, which provides guidance on accommodating car parking within the street environment; and
- Camden Parking and enforcement plan, which sets out a comprehensive approach to managing parking and addresses the need for effective enforcement of parking controls, for both on-street and off-street parking.

7 Vehicle access

KEY MESSAGES

- Planning permission must be sought for works to create or alter an access onto a classified road
- The Council will not approve applications that would cause unacceptable parking pressure or add to existing parking problems

- 7.1 This section gives guidance on designing developments to provide safe access and use by motor vehicles, ensuring that new means of access do not cause harm to the safety of other users of the development and the adjacent highway. It focuses on the Council's approach to planning applications that include new footway crossovers and new access routes to enable access to properties and sites.

Footway crossover

A dropped kerb or short ramp to permit vehicle access.

- 7.2 It relates to Core Strategy Policy CS11 - *Promoting sustainable and efficient travel* and policies DP18 - *Parking standards*; DP19 - *Managing the impact of parking*; and DP21 - *Development connecting to the highway network* within the Development Policies.
- 7.3 This section provides guidance on how proposals are judged in terms of:
- impact on the highway network and on-street parking conditions;
 - visibility and sightlines for emerging vehicles;
 - impact on the footway;
 - layout and dimensions for footway crossovers; and
 - Preventing waiting on the highway for schemes that include controlled access points, lifts and ramps.

When does this apply?

- 7.4 This guidance applies to planning applications that involve a change in the way that a site is accessed from the highway.
- 7.5 Planning permission must be sought for works to create or alter an access onto a classified road, including a crossover over a footway or pavement to provide access onto private land. However, there are certain circumstances where planning permission may not be required for access to a paved area or garage. These can include an access:
- from a road that is not classified (classified roads are listed in the Camden Network Management Plan);
 - to a property that is not subdivided into flats, and is occupied by a single household.

Classified road

A road which has a number in the national road system (i.e. M - motorway, A - first-class road, and B - secondary road).

- 7.6 Before considering applications for vehicle access we will first assess how an application has sought to minimise car use in accordance with Core Strategy Policy CS11 and policies DP16 - DP20 of the Camden Development Policies document. Relevant alternative measures include:
- provision for walking, cycling and public transport;
 - car-free development so that there is no need for parking; and
 - car clubs and pool cars.

- 7.7 It should also be noted that, separately to planning permission, consent is required from the relevant Highway Authority for a new or altered access from the public highway onto private land, and must be obtained before embarking on any work. The Council is the Highway Authority for all public roads in the Borough except the Transport for London Road Network (see Development Policies Map 1), for which, Transport for London is responsible.

How should vehicle access be provided?

- 7.8 Access to a site by motor vehicles will either be by driving over the footway using a crossover or the footway will be interrupted by a new junction to create a level access direct from the carriageway:
- Crossovers may be appropriate where the site is not intensively used by vehicles. The Council's Street Management Division will advise on the appropriateness of crossovers and, where a crossover is appropriate, will generally carry out its construction at the developer's expense, in accordance with the design requirements set out in the Camden Streetscape Design Manual;
 - Direct access using a new junction is likely to be appropriate either where the site is intensively used by vehicles, or where access is required by heavy goods vehicles. The Council will seek adoption of new roads, and so they must be designed in conjunction with the Council's Street Management Division (see Development Policy DP21).

Impact on the highway network and on-street parking conditions

- 7.9 The Council's approach to development and highway management is set out in policy DP21 of the Camden Development Policies, which seeks to ensure that new connections to the highway network from developments do not cause harm to the network, to its users or the environment. Applicants whose schemes will connect directly to the highway network should also refer to Camden's Network Management Plan and consult Council.
- 7.10 The creation of off-street parking and new access routes frequently involves the loss of on-street parking spaces due to the creation of a

crossover over the kerb. As set out in paragraphs 19.6 - 19.9 of the Camden Development Policies document, we will not approve applications for planning permission (and for highways consent) that would cause unacceptable parking pressure or add to existing parking problems.

- 7.11 Camden's Parking Enforcement Plan Parking provides regularly updated parking permit data, which is used to establish levels of on-street parking pressure on each of Camden's roads. This information will be used when considering the acceptability of applications that would involve the loss of on-street parking spaces.
- 7.12 We will require developments to be car free, where necessary, in order to avoid harmful impacts on on-street parking conditions through the creation of new access routes (see section 4 of this guidance for more information on our approach to car free development).

Visibility and sightlines for emerging vehicles

- 7.13 Vehicles joining the highway network need clear views of pedestrians, cyclists and other traffic, and users of the highway network need clear views of those joining it. Views can be obstructed by boundary treatments and parked cars. The relationship between motor vehicles and cyclists and pedestrians is particularly sensitive.
- 7.14 Adequate visibility for emerging vehicles should be provided with new vehicle accesses, or development that effects existing vehicular accesses. Developers should refer to the Manual for Streets for guidance.

Layout and dimensions for footway crossovers

- 7.15 It is essential that footway crossovers do not harm ease of pedestrian movement, and the front building line should provide a minimum pavement width of at least 1.8 metres. Any changes to the public highway would need to be approved by the highway authority and design details should be discussed with Camden highway authority prior to the submission of an application.
- 7.16 It is important that new access points are not overly steep, in order to allow for safe and convenient access. For normal pavement crossovers that involve a dropped kerb, the Council will apply the following gradients:
- Vehicular ramps from the carriageway to the area of level footway should be a maximum of 15% (1:6);
 - For pedestrians dropped kerbs should be a lower gradient.
 - For longer vehicular ramps, the Council will apply the following gradients:
 - Vehicular ramps should be a maximum gradient of 10% (1:10)

- For pedestrians, ramps should be a maximum gradient of 1:12, in line with the Disability Discrimination Act (DDA) requirements (although a gradient of 1:20 is preferred)

7.17 Where possible, the ground floor level of a development should be the same as the level of the highway, in order to avoid the provision of unnecessary steps, and to allow the footway to be constructed with an adequate slope (i.e. “crossfall”) to allow water run off.

Preventing waiting on the highway: Controlled access points, lifts and ramps

7.18 Sometimes it will be necessary to provide a limited amount of space for vehicles on the site or curtilage, with controls at the point of entry and/ or provision of vehicle space at a different level from the street, accessed by a vehicle ramp or lift.

Curtilage
The enclosed area of land adjacent to a dwelling house.

7.19 In each case, an area should be provided within the site for all vehicles waiting for a traffic signal, barrier or vehicle lift. This area should be sufficient to accommodate the maximum likely number of queuing vehicles, without any obstruction to pedestrians and vehicles using the public highway. Where a lift, ramp or other access is only available to one vehicle or direction of flow, there must be space at each end for leaving vehicles to pass those queuing to enter.

7.20 Depending on expected traffic flows, access roads may be expected to be two-way. Segregated areas for pedestrians and/ or cyclists may also be required.

Further information

7.21 The Council’s Road Network Management Plan establishes the road hierarchy in Camden and provides a list of classified roads in the borough. It sets out how the Council will manage the road network in order to provide for efficient movement of vehicles and pedestrians and reduce disruption and congestion.

7.22 The Camden Streetscape Design Manual provides information on the Council’s expectations for the detailed design and layout of highways, footways and public spaces in Camden. Detailed consideration should be given to the Manual before designing any highway works.

7.23 Other relevant documents include:

- Department of Environment, Department of Transport Design Bulletin 32 - Residential Roads and Footpaths - Layout Considerations – which describes the main considerations that should be taken into account in the design of residential layouts. It also takes into account new initiatives on matters such as road safety and includes references to improvement schemes on existing estates.

- Design Manual for Streets; DfT, 2007 – which provides advice for the design of residential streets and the creation of sustainable and inclusive public spaces.
- Design manual for roads and bridges – which is a series of 15 volumes that provide official standards, advice notes and other documents relating to the design, assessment and operation of trunk roads and motorways.

7.24 Regard should also be had to:

- the creation of high quality streets and public spaces (see section 7 of this guidance);
- potential community safety issues associated with forecourt parking – see Core Strategy policy CS17 and Designing safer environments section of the CPG1 Design.

8 Streets and public spaces

KEY MESSAGES

- New development should contribute to the creation of attractive, clean and well-maintained public places
- All new pedestrian areas and footpaths are required to be constructed to a standard that is considered appropriate for adoption by the relevant Highway Authority.

- 8.1 This section provides guidance on the design and layout of streets and public spaces. It aims to ensure that a good quality pedestrian environment and good pedestrian access are provided. This includes ensuring that development is accessible to all members of the community, including all disability groups.
- 8.2 The guidance relates to Camden Core Strategy Policy CS11 - *Promoting sustainable and efficient travel* and policies DP16 - *The transport implications of development* and DP17 - *Walking, cycling and public transport* and DP21 - *Development connecting to the highway network* in Camden Development Policies.

Public realm

All areas to which the public has open access.

Legible London scheme

A new signage scheme which aims simplify pedestrian movement around London.



- 8.3 This section includes guidance for the design and layout of streets and public spaces including:
- quality of the public realm;
 - ease of pedestrian movement;
 - street furniture;
 - footpaths that are not alongside roads,
 - our approach to shared surfaces; and
 - information on the Legible London scheme.

When does this apply?

- 8.4 This guidance applies to planning applications that involve a change in the way that pedestrians access a site or move in and around the site, and also applications that change vehicle movements in a way that will affect pedestrians.
- 8.5 It should guide arrangements for pedestrians that arrive by car, public transport or bicycle, as well as those arriving on foot.

The design and layout of streets and public spaces

CAMDEN STREETSCAPE DESIGN MANUAL (2005)

Provides useful guidance for those who are planning the design and layout of streets and public spaces. The manual sets out the Council's detailed expectations for street works in the borough, addressing issues such as responding to local character, footway design and materials, and street furniture.

General principles

- 8.6 We will seek improvements to streets and spaces to ensure good quality access and circulation arrangements for all. This includes improvement to existing routes and footways that will serve the development. Key considerations informing the design streets and public spaces include the following:
- Camden Streetscape Design Manual;
 - ensuring the safety of vulnerable road users, including children, elderly people and people with mobility difficulties, sight impairments, and other disabilities;
 - maximising pedestrian accessibility and minimising journey times;
 - providing stretches of continuous public footways without public highway crossings;
 - linking to, maintaining, extending and improving the network of pedestrian pathways;
 - maximising pedestrian safety by providing adequate lighting and overlooking from adjacent buildings;
 - taking account of surrounding context and character of area

- providing a high quality environment in terms of appearance, design and construction, paying attention to Conservation Areas, and using traditional materials (such as natural stone or granite setts) where appropriate,
- use of paving surfaces which enhance ease of movement for vulnerable road users; and
- avoiding street clutter and minimising the risk of pedestrian routes being obstructed or narrowed, e.g. by pavement parking or by street furniture.

Ensuring high quality public spaces

- 8.7 The Core Strategy seeks to ensure that new development contributes to the creation of attractive, clean and well-maintained public places (see Policy CS14). It is essential that new streets and public spaces integrate with surrounding spaces and links, and are designed and built to a high standard, including through the use of good quality materials. The government's Manual for Streets provides useful guidance on achieving successful public spaces, and Camden's Streetscape Design Manual sets out guidance on how to ensure works contribute to local character and distinctiveness.
- 8.8 Where developments generate the need for works to road, highways and adopted public spaces, these should be funded by the developer (see CPG8 Planning obligations for transport provision) but carried out by the council in order to ensure consistent high standards of implementation and materials in streets and public spaces. In line with policy DP21 of the Camden Development Policies, all new pedestrian areas and footpaths are required to be constructed to a standard that is considered appropriate for adoption by the relevant Highway Authority.

Street clutter

Excessive use of road signs, bollards and lampposts leading to an untidy street environment.

Ease of pedestrian movement

- 8.9 Footways should be wide enough for two people using wheelchairs, or prams, to pass each other. We seek to maximise the width of footways wherever possible. The Camden Streetscape Design Manual sets out minimum widths for different kinds of footways.

Wayfinding

The process of navigating or defining a path through an environment.

- 8.10 Policy DP21 of the Camden Development Policies document states that we will expect works affecting highways to avoid unnecessary street clutter. Design of footways should not include projections into the footway, unnecessary and cluttered street furniture or other obstructions. Any minimum standards for footway widths should not be used to justify the provision of unnecessary street clutter or reduction in footway width.

The Council will generally resist proposals that involve the opening of doors into footways as they raise safety concerns, and can obstruct pedestrians.

- 8.11 Footways should be designed with frequent and convenient road crossing points for pedestrians. The detailed design of edges, crossings and gradients should take into account the need for the maintenance of minimum pavement widths, ease of movement and wayfinding, and appropriate measures for those with visual impairments and mobility difficulties. The Camden Streetscape Design Manual and DETR 'Guidance on the use of Tactile Paving Surfaces 1998' provide useful guidance which should be used to inform the design of edges, crossings and gradients.

Tables and chairs

- 8.12 The Council will sometimes licence the placing of tables and chairs on the footway in association with adjacent cafes and similar uses. The area where tables and chairs may be placed must be designated and must not interrupt the area of footway for pedestrian movement. The licence will specify permitted hours, after which the removal of tables and chairs will generally be required. Further guidance on tables and chairs is provided in CPG5 Town centres, retail and employment.

Lighting, signage and street furniture

- 8.13 Footways should be well lit and well signed, but with care to avoid light pollution and obstructions. Wherever possible, lighting and signs should be placed on buildings or existing street furniture to minimise footway clutter. Please also see paragraphs 7.17 to 7.22 on Legible London below.
- 8.14 The installation of seating, bus shelters, litter bins and cycle parking is encouraged in association with new footways provided that it will improve the pedestrian environment, and the use of sustainable modes of transport. However, they should be positioned so they do not interrupt the minimum area of footway designated for pedestrians. If possible, cycle stands (and cycles parked at them) should be wholly clear of the footway.

Footpaths that are not alongside roads

- 8.15 Footpaths independent of roads can be beneficial in terms of directly following the most direct routes for pedestrians and creating pleasant environments. However, great care is needed to provide security for pedestrians and discourage anti-social behaviour. Designs should consider:
- lighting;
 - natural overlooking from adjacent buildings;
 - maintaining visibility over the full stretch of the route between roads;
 - the appropriateness of planting; and

- avoiding features that could conceal assailants.

Pedestrian and vehicle shared surfaces

- 8.16 Policy DP17 of the Camden Development Policies states that we will seek shared surfaces in appropriate circumstances and where it will be safe for all users. Safety and accessibility for all will be examined thoroughly in any shared surface proposal.

Shared surface

A highway where distinction between pedestrian and vehicle areas has been removed or reduced and sends a strong signal that the whole of the highway space is open equally to all users.

- 8.17 Where shared surfaces are used, a combination of other traffic management measures should also be used to reduce vehicle speeds to 5-10 mph. Measures to reduce vehicle speeds should not limit visibility for pedestrians and vehicles, and must not prejudice safety. Further measures to promote safety include
- the removal of parked vehicles from the shared surface to avoid potential conflicts with children at play; and
 - provision of clear routes and surface textures to assist orientation of people with visual impairments.

Legible London wayfinding signage

- 8.18 Legible London was set up by Transport for London (TfL) in partnership with London boroughs to create a standard pedestrian wayfinding and signage system for central and inner London. It is a map-based system which gives users a good understanding of the surrounding area and encourages them to choose their own route to a specific destination.
- 8.19 Legible London signage is supported in Camden's Core Strategy Policy CS11 as a key element of Camden's approach to promoting walking in the borough. It has also been adopted by other London boroughs and thus provides consistent pedestrian signage across central and inner London.
- 8.20 The Legible London standard has been adopted by Camden and all new signs on the public highway should be of a Legible London type. The Council will also seek Legible London signage on private land, where appropriate.
- 8.21 TfL's Legible London programme currently covers the Central London area and we will extend the Legible London scheme throughout the borough, prioritising key destinations and busier areas, such as our town centres (see Core Strategy Policy CS11 paragraph 11.11). We will seek on-site provision of Legible London signage in these areas as appropriate, and on developments that contain:
- key routes to or through the site;

- decision points, arrival points and places where pedestrians are likely to gather;
 - complex spaces and areas outside civic spaces and public buildings.
- 8.22 Where relevant, sign types and quantities should tie into any relevant area strategies produced by the Council, in partnership with TfL.
- 8.23 As well as on-site provision, developments will also be expected to provide contributions to the Legible London in other locations, where appropriate, in order to mitigate the increased level of activity their development generates (see transport section of CPG8 Planning obligations).

Highway authority approval

- 8.24 Works to streets and public spaces also require separate approval from the relevant highway authority (usually Camden council). You are advised to contact our Highways department as soon as possible to discuss the approach to and proposed works to streets and public spaces.

Further information

- 8.25 In addition to Camden's Core Strategy, Development Policies, the Camden Streetscape Design Manual and other sections in this guidance, reference should be made to the following guidance:
- Manual for Streets, DfT, 2007
 - Residential roads and footpaths: layout considerations – DfT Design bulletin 32 (2nd edition), HMSO 1992
 - Guidance on the use of tactile paving surfaces, DETR 1998 - this can be viewed on the 'transport infrastructure, pedestrians, wheelchair and scooter users' pages in the 'access for disabled people' section of: www.dft.gov.uk

9 Cycling facilities

KEY MESSAGES

This section includes guidance on:

- The implementation of our minimum cycle parking standards for new development;
- The design and layout of cycle parking; and
- Cycle hire and cycle stations.

9.1 This section provides guidance on meeting cycle parking standards in an effective way, so that cycle parking is convenient and secure, and users of a development are more likely to use bicycles to travel to and from the site.

9.2 It relates to Core Strategy Policy CS11 – *Promoting sustainable and efficient travel* and policies DP17 – *Walking, cycling and public transport* and DP19 – *Parking standards and limiting the availability of parking* of the Camden Development Policies. It should be read in conjunction with Development Policies Appendix 2 – Parking standards.

When does this apply?

9.3 This guidance applies to:

- Applications which involved the creation of one or more additional dwellings;
- Applications which proposed additional floorspace of 500 sq m or more; and
- Applications which are likely to significantly increase the demand for people to cycle to the site.

How do we implement our cycle parking standards?

9.4 Numerical standards for cycle parking spaces are introduced by policy DP18 of the Camden Development Policies, and set out in detail in Development Policies Appendix 2. These standards are applied at a threshold of 500 sq m in most cases. Throughout the standards, the stated number of spaces relates to the number of bicycles to be accommodated, not to the number of stands.

9.5 Where a development crosses the threshold, requirements apply to the entire floorspace, not only the floorspace above the threshold. For example, at a new leisure development, 1 visitor cycle parking space per 250 sq m is required from a threshold of 500 sq m. This means that no requirement applies to a facility of 400 sq m, but 4 visitor spaces are required for a facility of 1,000 sq m.

9.6 Thresholds and standards are given as a gross floor area (GFA) relating to the development as a whole, and are not intended to be applied

separately to individual units where a development is subdivided into smaller units. Thus, space for cycles may be required for small premises (under 500 sq m) which form part of a larger development.

- 9.7 Table 6.3 of the London Plan sets out additional cycle parking standards and states that additional cycle parking provision will be required for larger (C3) residential units.

Location, design and layout of off-street cycle parking

- 9.8 Cycle parking should be provided off-street, within the boundary of the site. Cycle parking needs to be accessible (in that everyone that uses a bike can easily store and remove a bike from the cycle parking) and secure (in that both wheels and the frame can easily be locked to the stand). Security is a critical concern in the location, design, enclosure and surveillance of all cycle parking. The table below provides detailed guidance on the location, design and layout of cycle parking for various groups of cyclists.

Location of off street cycle parking

General

- Cycle parking outside buildings should be positioned near entrances and where frequent surveillance is possible. For short stays, the parking should be sited within 25 metres of building entrances. For stays of over an hour, the parking should be sited within 50 metres of building entrances.
- All cycle parking, including all parts of the parked cycles, should be clear of routes needed for pedestrian movement.
- The route to cycle parking from street level should be step free. cycle parking inside buildings should be at the entrance level of the building or accessible by a ramp or lift from street level that can accommodate a bike.

Parking for visitors

Parking for visitors should be clearly visible or clearly signed from the public highway, and should be near building entrances

Parking for employees (and other long stay parking)

Parking for employees (and other long stay parking) should be provided either within the building, or otherwise protected from the weather. Consideration should be given to providing lockers and showers for cyclists. For larger development this would be expected and would be a requirement of a Travel Plan (see section 2 of this guidance concerning Travel Plans).

Parking for residents

Parking for residents should be within the building. Parking for a resident may take the form of a space within an individual dwelling provided that the space is close to the door of the dwelling, and access to the dwelling is level, or by a ramp or lift that can accommodate a bike.

Design and layout of cycle parking: Sheffield and “Camden” cycle stands

The Council recommends the use of either “Camden” or Sheffield for the provision of off-street cycle parking, as they meet the Council’s requirements in terms of accessibility and security, provided they are laid out correctly.

- The “Camden” stand is a new form of Sheffield Stand, which is now used for all new cycle parking installed on Camden’s public highway. Developers are encouraged to use it in place of the Sheffield stand, although the Sheffield stand is still acceptable. The Council’s Public Realm and Transport team can advice on purchasing “Camden” stands as they are not as widely available as the Sheffield stand.
- The Sheffield Stand is the most common type of cycle stand used in the public highway. It is recommended for use along with Josta two-tier cycle parking;

Annex 1 provides more detailed guidance on the design and layout of “Camden”, Sheffield and Josta stands.

We are willing to consider other forms of cycle parking, however you must meet our accessibility and security requirements, details of which can be obtained from the Council’s Public Realm and Transport team. Generally, designs that require cycles be lifted into place or provide insufficient opportunity to lock the cycle will not be acceptable.



The London Cycle Hire Scheme

- 9.9 The London Cycle Hire Scheme is a public bicycle sharing scheme for short journeys in and around central London. Users can pick up a bike from a docking station, use it for short journeys, then drop it off at any docking station, ready for the next person.
- 9.10 Whilst the cycle hire scheme is currently focused around central London, the Mayor of London is investigating its expansion. The Camden Core Strategy states that we will seek to ensure that the scheme is extended to key destinations across the borough, including our town centres (see Core Strategy paragraph 11.13).
- 9.11 Where appropriate, developments close the area covered by the London Cycle Hire Scheme will be expected to contribute towards the scheme,

where justified as a result of increased trips generated. Contributions could include:

- a financial contribution towards cycle hire facilities. The amount sought will be based on the number of additional trips that are generated by the scheme;
- provision of space on-site to accommodate new cycle hire docking stations, in larger developments where there is space and the location is suitable. Transport for London (TfL) is producing a set of guidance for developers regarding specifications and design requirements for docking stations due to be released in 2011.

9.12 Contributions sought will relate both to the individual impact of a scheme and to any cumulative impact of a number of schemes in the same area.

Cycle stations

9.13 Cycle stations provide a secure managed area for cycle parking. The Camden Core Strategy promotes the provision of cycle stations as part of an effort to increase the availability of cycle parking in the borough (see paragraph 11.13 of the Core Strategy), and we intend to create a network of publically accessible cycle stations across the borough.

9.14 We will seek the provision of cycle stations in locations where it will be possible to attract a sufficient number of users. Suitable locations include:

- town centres and the central London area;
- transport interchanges;
- large commercial developments;
- residential areas - linked to new and existing residential development of a suitable scale; and
- larger health and education facilities.

9.15 Where developments generate an increased level of activity they will be expected to provide contributions towards the provision and maintenance of nearby cycle stations, in order to mitigate the effects of the increased number of journeys.

9.16 We will also seek on-site provision of cycle stations as part of larger developments in suitable locations. On-site provision of cycle stations can incorporate a development's cycle parking requirements for visitors (as set out in our parking standards), but should also include extra provision for the wider public. Parking provision for employees and residents of a development, as set out in our parking standards, should be provided separately in order to ensure that they retain the appropriate number of spaces to meet the demand that they generate.

Design of cycle stations

9.17 As a minimum, cycle stations should incorporate indoor, sheltered standard cycle parking (e.g. Camden or Sheffield type cycle stands) with

controlled access to the indoor area, and lighting. Cycle stations can incorporate a variety of other features including automated cycle locks, changing facilities, lockers, toilets and showers. Access to and from the cycle station by bike must be safe and convenient and accounted for within the space.

9.18 The Camden Cycle Stations Programme - Review of Best Practice (March 2009) provides information on best practice in the provision of cycle stations. Features that contribute to a successful cycle station include:

- Being located not more than 100m from the target destination, with shorter stays requiring shorter distances;
- Good surveillance by staff, other users and passers-by.
- Effective maintenance and management
- Clear and unambiguous signing to and within the cycle station.

Further information

9.19 In addition to the guidance provided in Annex 1 below (which includes details on the layout of off-street cycle parking), reference may also need to be made to the Camden Streetscape Design Manual. The manual contains dimensions for on-street cycle parking and the widths required for unobstructed pedestrian routes.

9.20 Other supporting documents include:

- Forthcoming TfL Design and specification of cycle hire scheme
- Forthcoming TfL Guidance on Cycle Stations
- Camden Cycle Stations Programme - Review of Best Practice (March 2009)

9.21 London Cycle Network Design Manual (London Cycle Network Steering Group, March 1998)

Annex 1 – Sheffield Stand Cycle Parking

9.22 This Annex describes in detail how to lay out Sheffield stands. It also can also be applied to the layout of “CaMden” stands.

9.23 The "Sheffield Stand" refers to a common design of cycle parking made from a tubular steel loop, approximately 50mm to 75mm in diameter, that is fixed to the ground (either bolted through a baseplate or set in concrete). Each Sheffield Stand can accommodate two bicycles, one either side, provided there is sufficient clearance next to the stand and sufficient circulation space so all cycle parking spaces can be accessed

9.24 The CaMden Stand is similar to the Sheffield Stand but is in the shape of a rounded “M” rather than a simple loop. This is designed to encourage users to lock both wheels and the frame to the stand, rather than just the top tube / frame.

Figure 3. Sheffield Stand Elevation

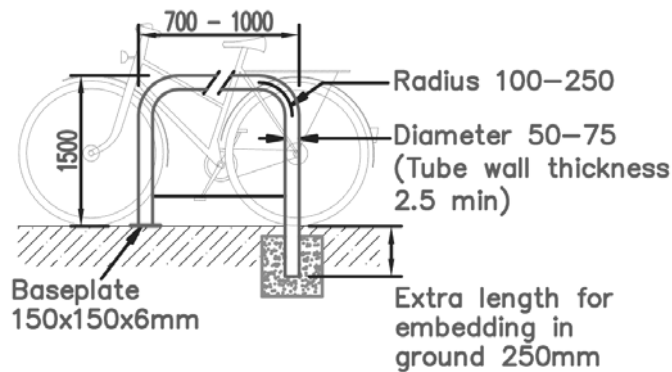
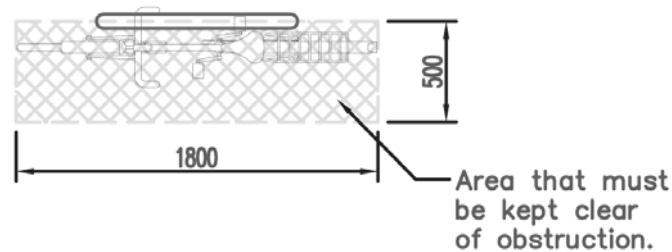
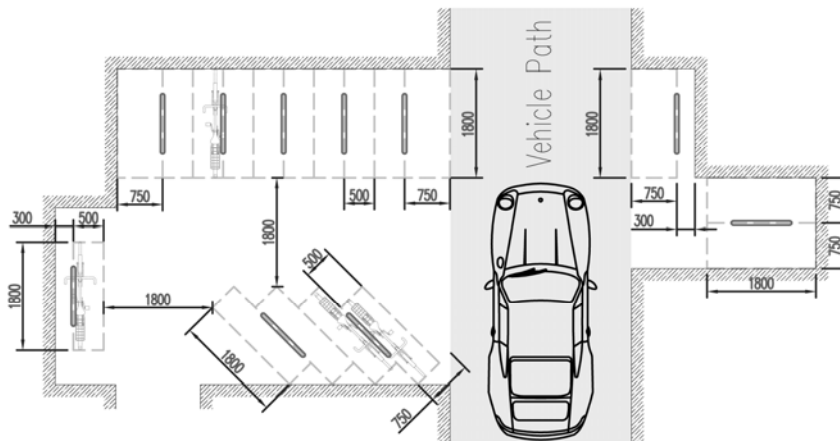

Figure 4. Sheffield Stand Plan



- 9.25 For adjacent stands, an area of at least 1800mm by 500mm next to the stand (measured from the centre line of the tube), must be kept clear for each cycle parking space to allow room for the cycle and working space for locking the bike to the stand. However, if a stand is next to a physical obstruction, such as a wall or a vehicular path, there must be at least 750mm between the stand and the physical obstruction to enable both sides of the stand to be used. If a stand is to be placed close to a wall or other physical obstruction so that only one side of it can be used (i.e. only one cycle can be locked to it), there must be at least 300mm between the stand and the physical obstruction.
- 9.26 Aisles around the cycle store must be at least 1800mm in width. An example cycle store showing various layout options is shown below. Note that the area to be kept clear does not actually have to be marked on the ground, but is shown in outline for clarity.

Figure 5. Cycle stand siting



Josta Two-tier Cycle Parking

- 9.27 The Josta two-tier cycle parking system (or similar) is generally able to accommodate approximately twice as many cycles per square meter of floor space as Sheffield stands. It also still meets the Council's requirements for accessibility and security, but requires a ceiling height of at least 2500mm.
- 9.28 With a ceiling of at least 2500mm the stands can be placed 650mm apart, i.e. $X = 650\text{mm}$ in the diagram below.

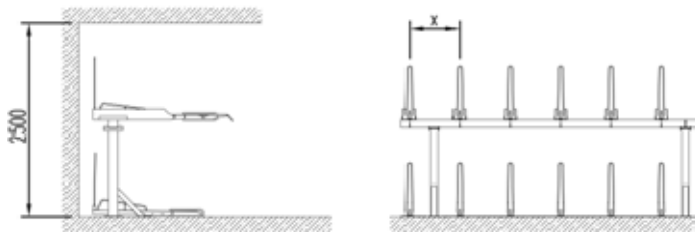

- 9.29 With a ceiling of at least 2700mm the stands can be placed 400mm apart, i.e. $X = 400\text{mm}$ in the diagram below.

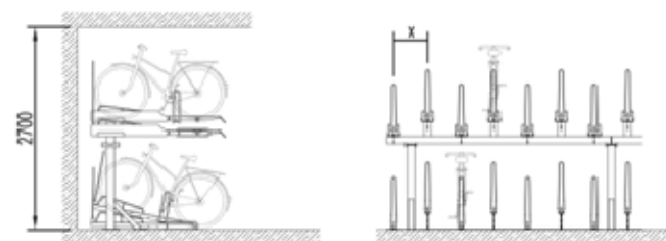

- 9.30 In order to enable the top tier to be used, at least 2500mm of clearance in front of the stand, measured on a line at the same angle at which the top tier stands are extended (see diagrams below), is required between rows of stands, walls or other obstructions.

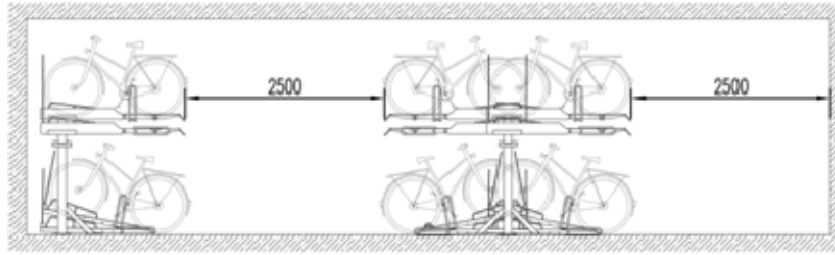

- 9.31 The Josta stands can be arranged at different orientations (angles) provided there is 2500mm of clearance in front of the rack to remove cycles from the top tier (as described above) and aisles around the cycle store at least 1800mm in width. Examples, with minimum distances are shown below. "X" indicates the spacing between stands, which depends on the ceiling height as described on the previous page.

Figure 6. Josta Stand minimum siting dimensions

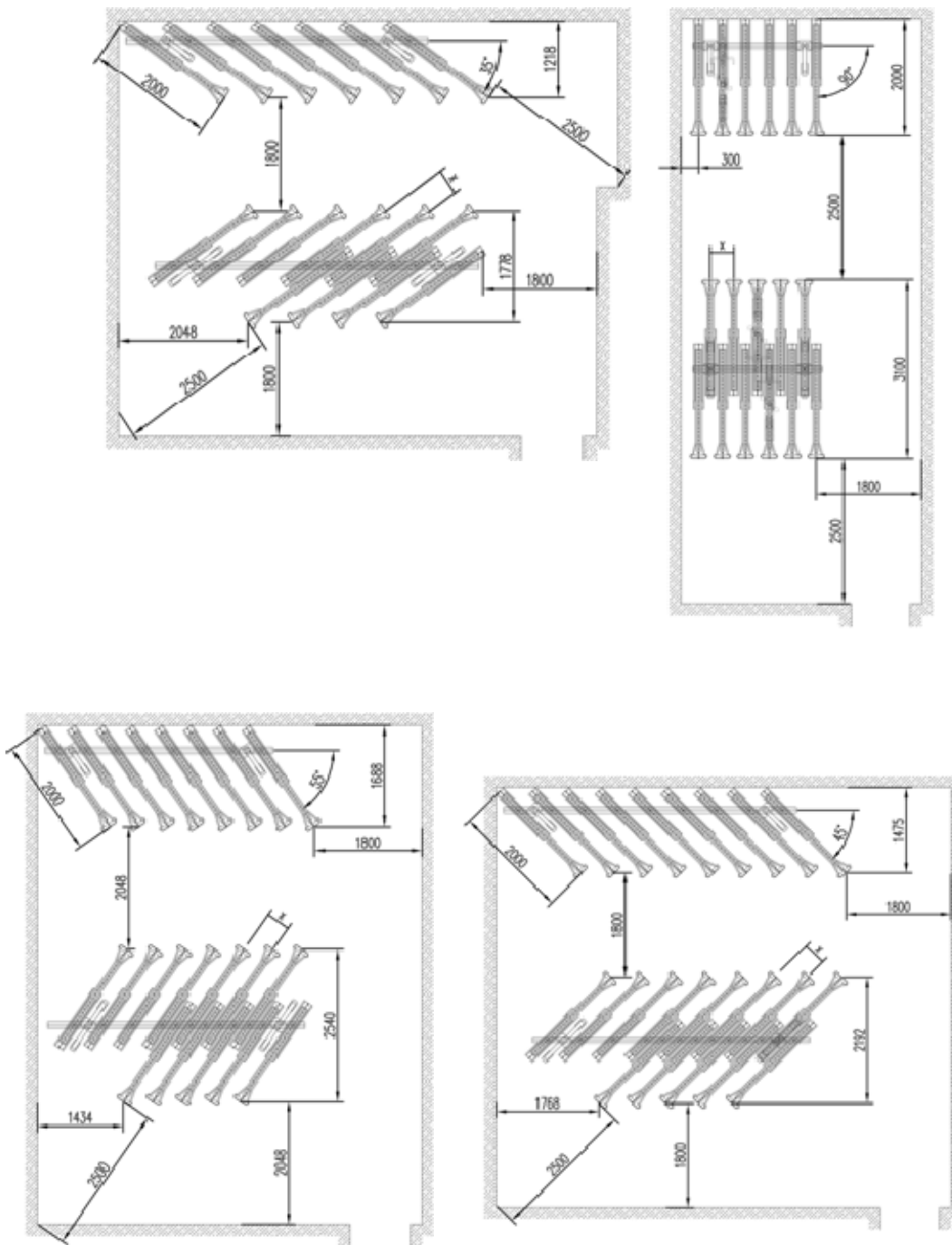

10 Minicab offices

KEY MESSAGES

- The Council will seek to minimise any impacts caused by minicab offices relating to emissions, noise, highway and traffic problems, and community safety
- The Council will resist minicab offices in locations which adjoin residential accommodation

10.1 This section provides guidance on the provision of minicab offices in Camden, setting out the main issues which should be considered in order to minimise their impact, and the most appropriate locations for them.

10.2 It relates to policy DP12 - *Supporting strong centres and managing the impact of food, drink, entertainment and other town uses* of the Camden Development Policies.

When does this apply?

10.3 This guidance applies to all applications concerning minicab hire offices, including both change of use applications and proposals for extensions and internal and external alterations to existing premises.

10.4 In some circumstances mini-cab offices fall within the B1a use class, specifically where cabs are controlled remotely from a small office. For a mini-cab office to be considered within such a use the premises would have no defined frontage distinct from the existing office accommodation and the presence of the mini-cab office would not be advertised outside. The intent therefore would be to remotely control drivers and not to attract passing trade to come into the premises to order cabs. There would be no element of taxis ranking up, whether formally or informally, to pick up customers from the premises.

How should minicab offices be provided?

10.5 Minicabs make a valuable contribution to the transport needs of Camden's residents and workers and provide new business opportunities and employment. However, we must balance the needs of minicab businesses with the need to minimise traffic congestion and protect residents from undue disturbance, particularly as minicab offices tend to operate for 24 hours a day. Particular issues that may arise from minicab offices are emissions and noise, highway and traffic problems, community safety and the fear of crime.

Location

10.6 Policy DP12 in Camden Development Policies acknowledges that town and neighbourhood centres are generally the most appropriate location for minicab offices although we will carefully consider their potential

impact when assessing planning applications to make sure that they do not harm the centre or the amenity of neighbours.

- 10.7 We will resist minicab offices in locations which adjoin residential accommodation.
- 10.8 We welcome the use of radio-controlled vehicles since this reduces the need for drivers to return to the office for each fare which, in turn, should reduce any disturbance to nearby residents and minimise traffic congestion.

Extensions

- 10.9 Should you wish to extend an existing minicab office, or change its appearance you may need to apply for planning permission, and you should contact the Council to check. If the building is listed you may need listed building consent for alterations both inside and outside. Further advice on listed buildings is contained within CPG1 Design (Heritage).
- 10.10 Extensions should not occupy car parking or access areas. Where this is proposed you will be required to reprovide parking and provide a new access. Extensions or alterations that make access for vehicles dangerous will not be permitted. Further general guidance is provided in CPG1 Design (Extensions, alterations and conservatories).

Additional controls

- 10.11 The following additional controls may apply to minicab offices:

Off-street parking

- 10.12 Minicab offices should, where possible, provide off-street car parking for drivers visiting the office. This parking should be located within or in close proximity to the office site.

Advertisements and shopfronts

- 10.13 Minicab offices will be subject to the same controls on advertising and shopfronts as other town centre uses. You should refer to CPG1 Design for detailed guidance on Advertisements, signs and hoardings and Shopfronts.

Soundproofing

- 10.14 Soundproofing may protect adjoining premises from noise disturbance. This is particularly important where minicab offices include waiting rooms for customers. Internal soundproofing cannot, however, reduce outdoor noise from car doors, slamming, engines, horns etc or alleviate the disadvantages of an inappropriate location.

Satellite dishes and antennae

- 10.15 Satellite dishes or radio antennae may be required and this equipment should be away from the view of nearby residential properties or public areas. If the building is listed, or in a conservation area, special care is required to ensure that the equipment does not affect the traditional character of the building or its setting. Additional guidance is contained within CPG1 Design (Heritage and Building services equipment). Please note that satellite dishes and radio antennae may require permission from the council before they are erected.

Access

- 10.16 If customers can visit your offices you should try to ensure that it is accessible to all members of the public. Further guidance on the measures that could be introduced to enable this is contained within Camden Planning Guidance on access for all.

Marshalled Taxi Ranks

- 10.17 The Council is keen to introduce marshalled taxi ranks in busier nightlife areas such as Camden Town, in order to ensure the safe loading of passengers into taxis and to help reduce any alcohol-related problems which may arise in such locations. Should a managed taxi rank be introduced, community safety will be a key issue and we will encourage the installation of additional lighting, security cameras and regular police patrols to monitor the area.

Index

Car clubs	31	Electric charging points	32
Car free and car capped development.....	25	Legible London	45
Car parking (on-site).....	29	Minicab offices	56
Cycle hire scheme.....	49	Servicing management plans	21
Cycle parking.....	47	Street furniture	44
Cycle stations	50	Streets and public spaces	41
Cycling facilities.....	47	Transport Assessments.....	7, 8
Disabled (parking)	28	Travel plans	13
		Vehicle access.....	35

Strategic Planning and Information
London Borough of Camden
Town Hall Extension, Argyle Street
London WC1H 8EQ
Tel: 020 7974 2043 / 2519
Fax: 020 7974 1930
Email: ldf@camden.gov.uk
www.camden.gov.uk