



## Josta 2-Tier Bicycle Racks

The market leaders in high capacity bicycle racks, offering space efficient and cost-effective cycle storage.

- Double the capacity of bicycle storage spaces
- Easy and safe to use - with a proven track record in the UK, Europe, Australia and the USA
- Space efficient
- Flexible and adaptable
- Neat and organised
- Individual racking – one bike per space
- No maintenance required
- Patented gripping system keeps bike securely in place
- Maximises cycle parking spaces, and allows more car parking (if required) or creates space for other uses
- Achieves cycle-parking requirements in buildings with limited space



### Ideal Applications

- Bike-Stations and Bike-Parks
- Train and bus stations
- Commercial or residential projects
- New shelters and compounds
- Custom storage spaces



The easy operation of the Josta 2-Tier

### Liverpool Street Station, London

Liverpool Street station in London more than doubled its bike parking in a limited space, from 80 - 189, with the Josta 2-tier racks.



Before



Doubles the storage space in shelters



After

Please contact us for more information on:

Tel: 02392 815555  
Email: [info@cycle-works.com](mailto:info@cycle-works.com)  
Web: [www.cycle-works.com](http://www.cycle-works.com)

**JOSTA**®



## The Josta 2-tier rack is a high capacity double decker bicycle rack.

Josta is the market leader for high capacity racking systems. The racks are popular across Europe, the USA and now Australia. Many bike stations in Germany, Holland and the US specify the Josta rack as standard. Cycle-Works are the UK's exclusive distributor of the Josta 2-Tier rack system and have extensive experience of cycle parking including shelters, racks and bike lockers.

The Josta 2-tier sites range from small open access installations of less than 80 bike spaces (e.g. Surbiton station) to large manned cycle parks of 7000 (e.g. Leiden, NL). They are also increasingly used in the basements of new office blocks and apartments (e.g. the prestigious Foster's Albion Riverside development in Battersea).

## Why the Josta rack is the market leader in high capacity bike parking

This space-efficient racking system stores one bike directly above the other. It therefore increases the amount of bicycles parked (or reduces the size of the site) by up to 50%.

The rack is custom-made for specific sites to maximize the cycle parking capacity, and can be used in conjunction with other systems.

A special, patented gripping mechanism ensures that the bike cannot roll back and injure the user. We find that the top racks are usually filled first as users like to store their bike 'out of harm's way'. It is also easier to lock the bike when on the top rack. This usually leaves enough space in the bottom row for users who do not wish to use the top row.

## Layout and Space Requirements

This racking system can be designed to fit your exact space. It can be used in conjunction with our other cycle parking systems to give the maximum capacity for your site.

Please contact us for more information on:

**Tel: 02392 815555**  
**Email: [info@cycle-works.com](mailto:info@cycle-works.com)**  
**Web: [www.cycle-works.com](http://www.cycle-works.com)**

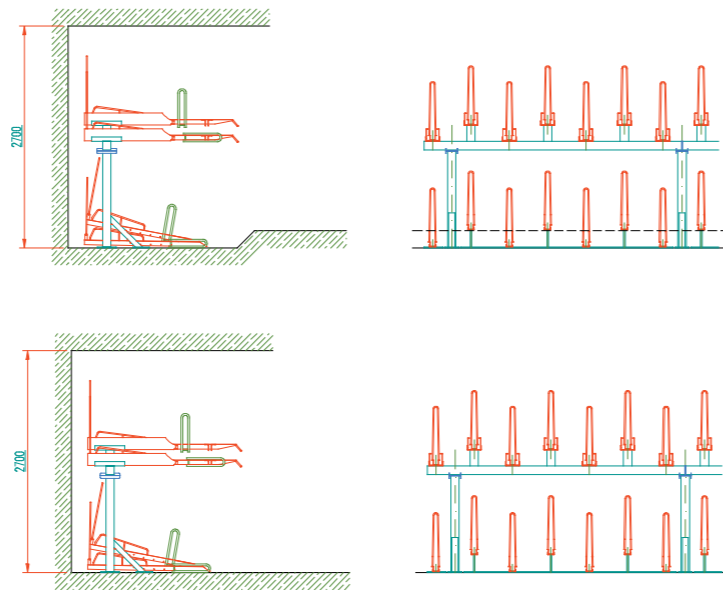

## Site Planning

We are happy to give advice or assist you with your site planning. For this, please let us have a site plan (DWG or PDF format), clearly marked with all relevant dimensions, obstacles and access ways. Please see the next page for a guide on designing a site yourself.

Please contact us to obtain DWG files of the product layout.

## Mounting/Installation

A level concrete base is usually required. This racking system is then installed by our team of experienced installers. Special supports for non-concrete sites with strong level surfaces can be supplied for a small additional charge.

## Material options

These racks are usually galvanised with a red handle on the top racks.

## Locking mechanisms and options

A security bar allows the cyclist to lock the bike frame and wheels with their own chain or D-lock. The front wheel and frame can also be locked easily.

## Delivery

The current lead time is 8-12 weeks, but larger projects can require more than this. It is really beneficial if Cycle-Works are involved in the site planning as soon as possible.

## To design a site, please follow these guidelines:

- The headroom is the most important factor for this racking system. A minimum of 2600mm is required for maximum capacity.
- Leave 300-400mm to any adjoining side wall to give space for the handlebars.
- The racks are then spaced at between 395mm and 500mm apart.
- We have found 450mm to be a good planning spacing, giving capacity as well as ensuring ease of use.
- Please allow 2000mm for the rack itself, plus between 1700mm and 2500mm in front for access. This access space can be used by the next row as well.
- The racks can also be installed from a central spine. For this option, please leave 2000mm for access on both sides. The 2-sided unit is then 3100mm wide.
- Racks can also be installed at a 45 or 55 degree angle to minimise space.

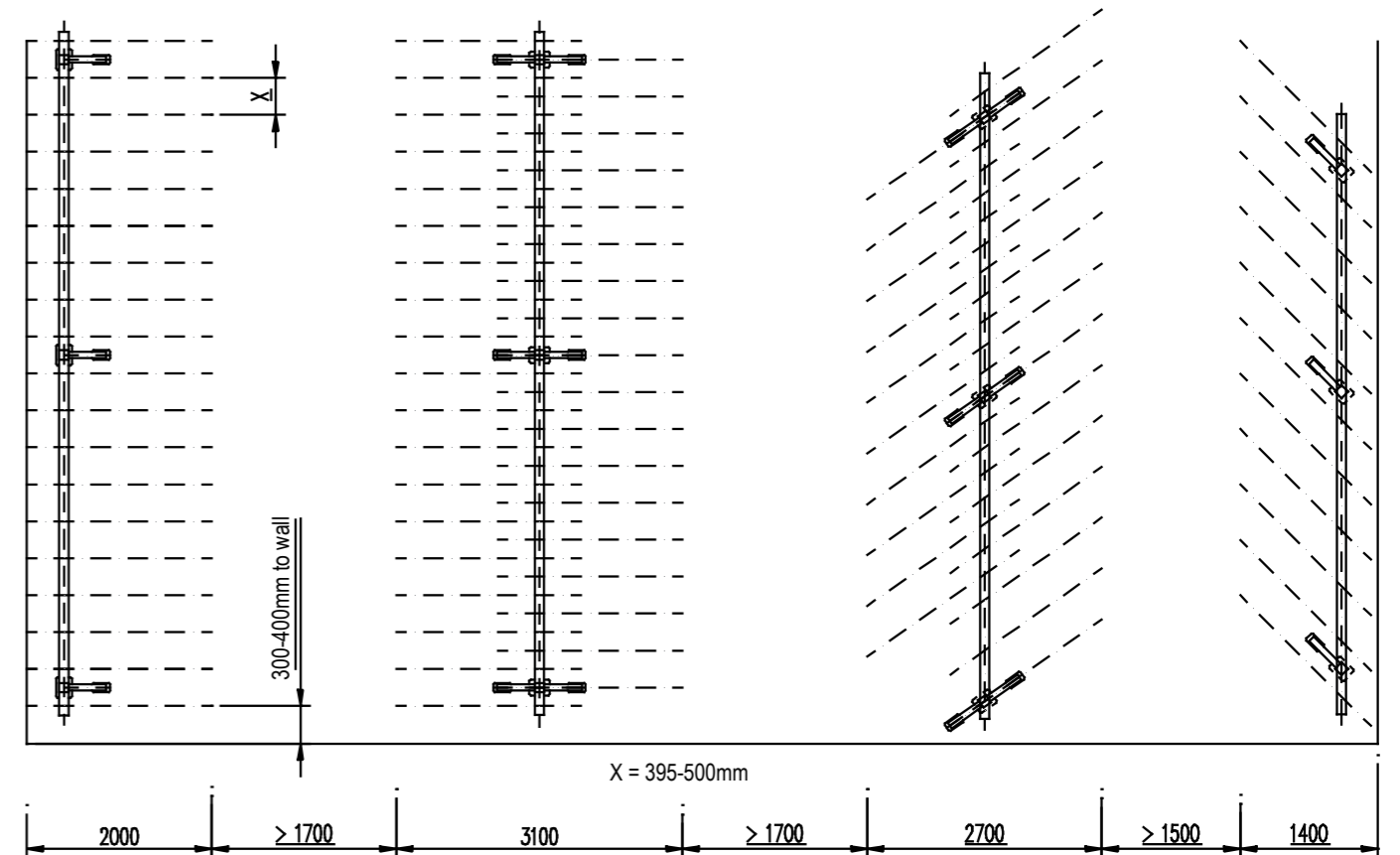
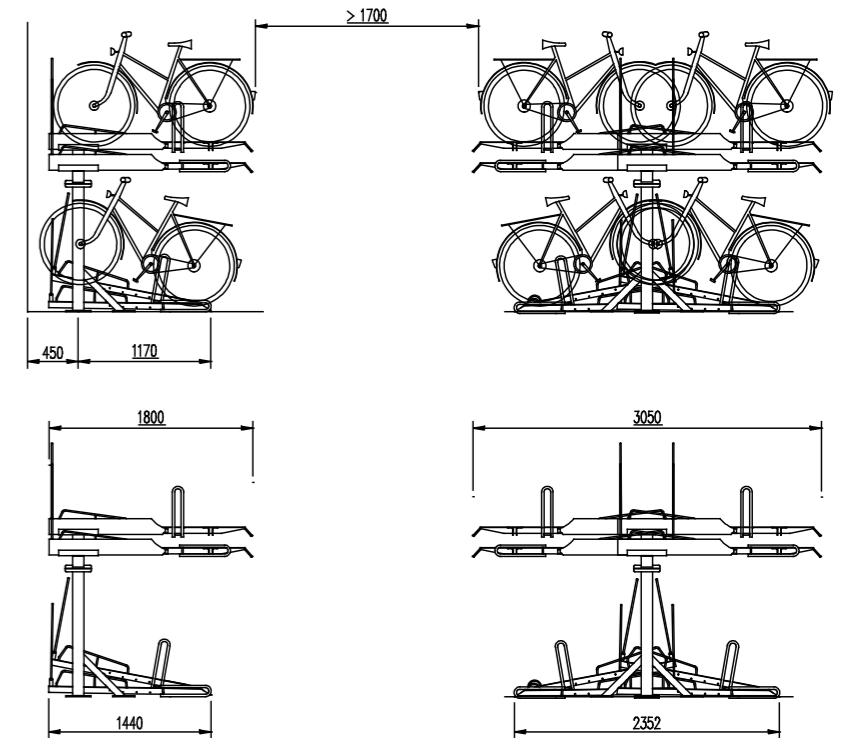

### Store a bike in four easy steps

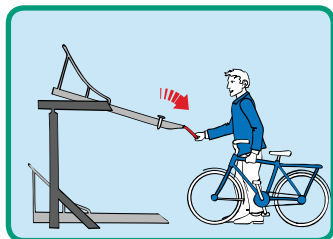

1. Pull handle to lift the rack toward you.

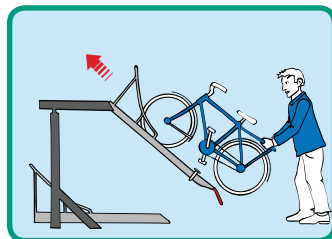

2. Lift front wheel onto the rack and push up.

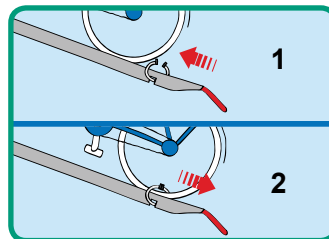

3. The wheel is gripped automatically.

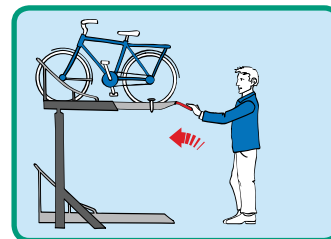

4. Lock the bike and lift the rack back into the upright position.

### Retrieving a bike in four easy steps

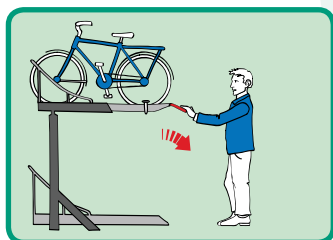

1. Pull handle to lift bike toward you.

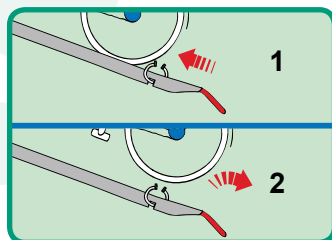

2. Pull the bike forwards to release the wheel lock.

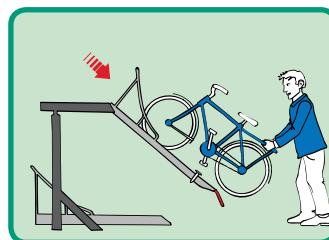

3. Unlock and slide the bike down.

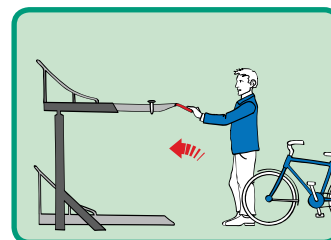

4. Lift the rack back into the upright position.

### Shelters

Cycle-works can also provide a range of quality shelters to complement the Josta 2-tier rack. These can be customised as required.

#### Shelter height:

2700mm recommended  
2600mm minimum



Berlin shelter - single sided



Berlin shelter - lockable compound



Solent extended shelter (Upminster station)



Custom metal shelter (St. George's Hospital)



Custom wooden shelter

Please contact us for more information on:

**JOSTA®**

Tel: 02392 815555  
Email: [info@cycle-works.com](mailto:info@cycle-works.com)  
Web: [www.cycle-works.com](http://www.cycle-works.com)

