

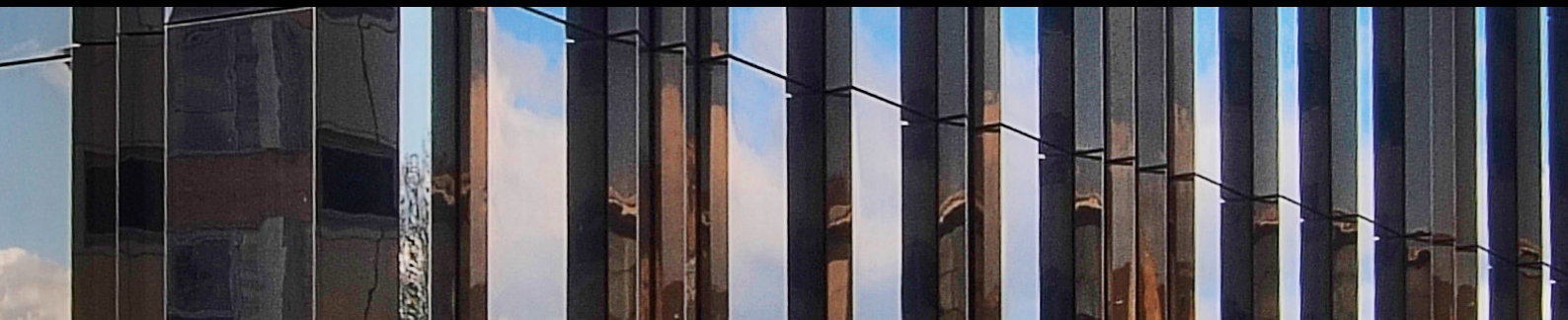



CI/SfB	(41)	Nh2
January 2016		





Proteus HR is the leading solution for creating metal façades. Available in steel, aluminium, zinc, stainless steel, copper alloys and other metal finishes, it uses a honeycomb core to achieve a perfectly flat finish and a very large panel size, allowing for large spans and stunning visual effects. It's lightweight, reducing the load on the building, yet also strong and safe, offering superb protection for the structure.

The Proteus HR range offers a broad selection of standard configurations, which can also be customised and adapted to create a unique look for individual projects.

Contents

What is Proteus HR?	04
Proteus HR projects	06
Technical information	10
Materials and finishes	12
Project services	14

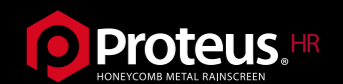

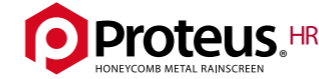

What is Proteus HR?

Proteus HR is an integrated modular rainscreen system that offers a flat façade with recessed joints in steel, aluminium, zinc, stainless steel, copper alloys and other materials.

Proteus HR consists of an aluminium honeycomb core, structurally bonded between two thin gauges of lightweight metal skin. Each panel is supported by the unique Proteus system of aluminium carriers and ancillary components, which can be installed on to any type of wall construction.

The naturally optimised structure of Proteus HR's honeycomb core delivers maximum compression and shear resistance with minimal material. This means that lightweight, economical panel skins can be used, minimising the load transferred to the main structure and reducing overall material requirements compared to a conventional metal rainscreen panel.

What is rainscreen?

Rainscreen cladding is the attachment of an outer skin of rear-ventilated cladding to a new or existing building. The system is a form of double-wall construction that uses an outer layer to keep out the rain and an inner layer to provide thermal insulation, prevent excessive air leakage and carry wind loading. The outer layer breathes like a skin while the inner layer reduces energy losses.

The structural frame of the building is kept absolutely dry, as water never reaches it or the thermal insulation. Evaporation and drainage in the cavity removes water that penetrates between panel joints.

Water droplets are not driven through the panel joints or openings because the rainscreen principle means that wind pressure acting on the outer face of the panel is equalised in the cavity. Therefore, there is no significant pressure differential to drive the rain through joints.

During extreme weather, a minimal amount of water may penetrate the outer cladding. This, however, will run as droplets down the back of the panels and be dissipated through evaporation and drainage.

Large-format panels with exceptional flatness and tight radii at the edges

Each panel can be individually adjusted and demounted

High resistance to impact, thermal bow and 'oil canning'

Flat, curved, corner and soffit panels available in a range of sizes, thicknesses and metal finishes

All panels assembled at our factory and pre-finished for rapid installation on site

Fully tested and compliant with CWCT standards

Composite construction can be broken down and fully recycled

1. Backing Wall

The backing wall shall be a structure that will carry both the self-weight of the Rainscreen system and wind loading, it will provide fire resistance and will provide an airtight seal for the building. The Proteus HR system is designed to be installed on all types of backing walls such as blockwork, precast concrete, timber frame, SIPS panels, SFS and insulated steel panels.

2. Vapour Control Layer

It is important to recognise and address the need for including a Vapour Check or perhaps a breather paper to the warm side of the insulation should the backing wall not be adequately sealed. This is an essential consideration to avoid the problem of interstitial condensation and air leakage.

3. Insulation

Thermal properties shall be selected in order to reduce the total in-service energy consumption of the building thus limiting the levels of carbon emissions. Carbon emissions will be lower when heat transfer and air leakage through the building envelope are reduced and cooling loads arising from solar gain are reduced. The specified Insulation can be provided either within the inner wall or in the air cavity. In all cases, we recommend a clear air cavity of at least 38mm between the rear of the panel and the face of the Insulation/Substrate.

4. Panel Support System

Proteus HR panels are fitted to vertical mullions that are fixed to the backing wall with adjustable support brackets. Mullions consist of extruded aluminium sections including location channels, which provide adjustable fixing locations for panels and support brackets. We can provide support systems both horizontally & vertically, for shallow & deep cavities and for both long spanning and continuously fixed applications.

5. Panels

Pre-engineered outer and inner skins are structurally bonded to the aluminium honeycomb core. The panels peripheral extrusion provides a fixing location for the support brackets to all edges of the panel. The panels provide the main defence from water, snow and wind transferring these loads through the carrier system back to the backing wall. Panels are supplied shrink-wrapped on pallets, with a strippable film. Each one is individually numbered, providing full traceability.

6. Panel Joints

Panel joints are baffled with the intention to prevent the gross ingress of water and snow either impacting on the joint surfaces or falling out of suspension in the air and draining out of the joint. The standard jointing arrangement provides a 15mm wide vertical and horizontal recessed joint. The baffle strip is inserted into the joint after fixing the panels which conceals all fixings, the infill strip is provided in black as standard but can also be a contrasting colour or a metal baffle matching the panel skin.

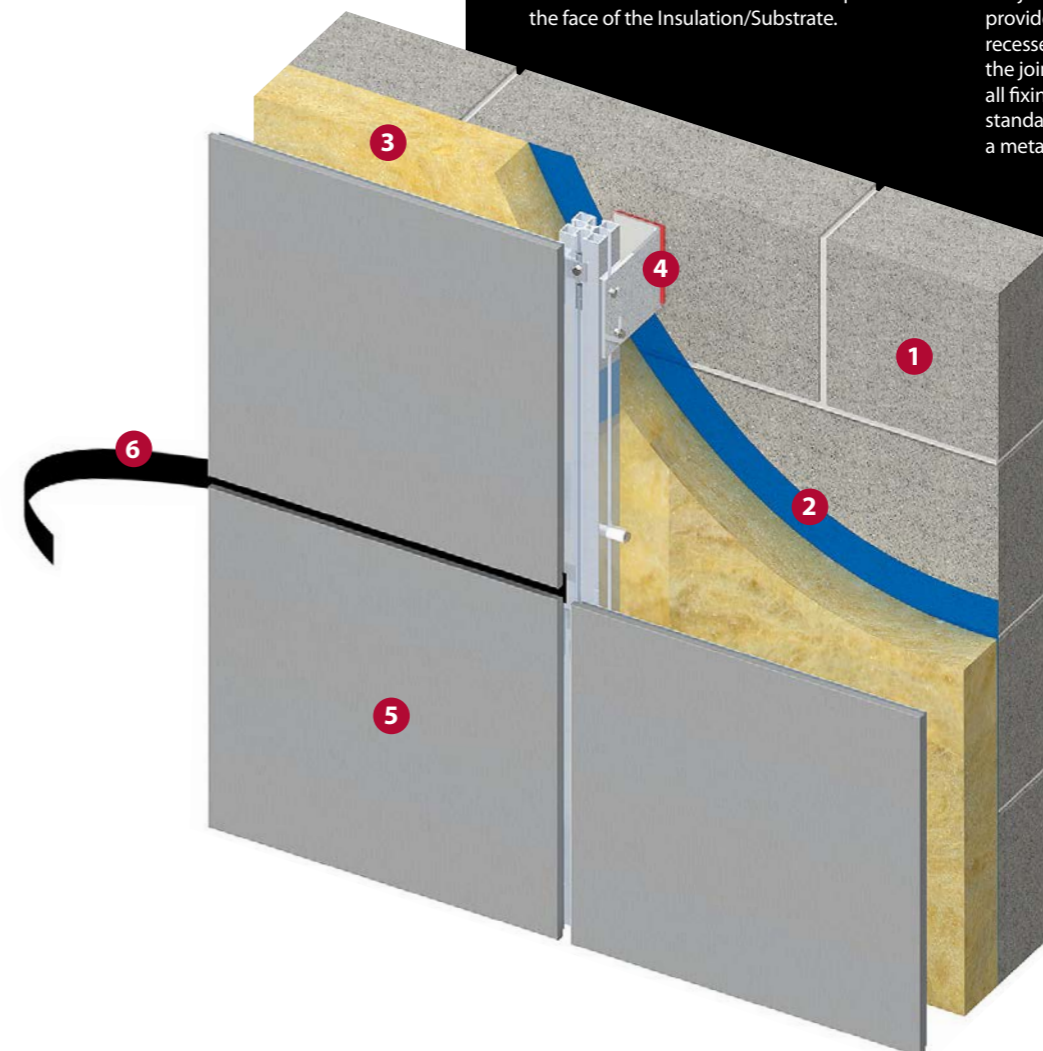

Proteus HR projects

Proteus HR is suitable for a range of buildings, from offices and other workplaces through to public buildings and residential developments. The images here reflect just a few of the high-profile schemes that have used Proteus HR.



Project:
Imperial Tobacco
Headquarters (Phase 1)

Sector: Office
Architect: AWW
Finish: Nedzinc Nova, Polyester
Powder Coated Aluminium,
VM Zinc Anthra



Project:
East London Line Stations

Sector: Infrastructure
Architect: Scott Wilson Architects
Finish: Rimex Canvas
Patterned stainless steel

Project: Heathside & Lethbridge

Sector: Residential
Architect: BPTW Architects
Finish: Post coated steel



Project:
Marks & Spencers Archive,
Leeds Unversity

Sector: Education
Architect: Broadway Malyan
Finish: Mirror finish coloured
Stainless Steel

Designed by Broadway Malyan the new archive building provides the University of Leeds and Marks & Spencer with a modern repository for their most valuable books, magazines, historical photographs, films and historical papers.



Section drawings

Horizontal joint

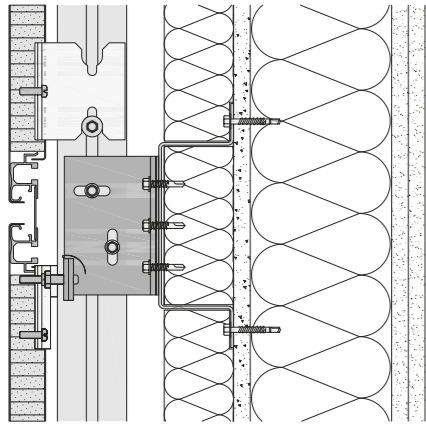

Termination

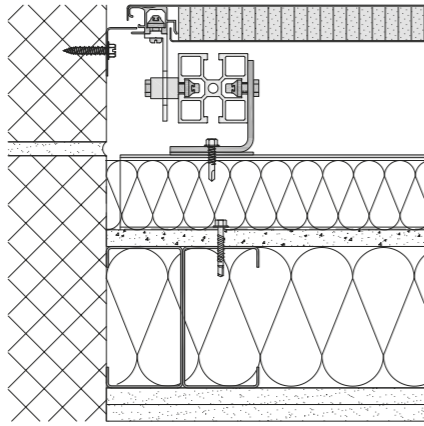

Capping

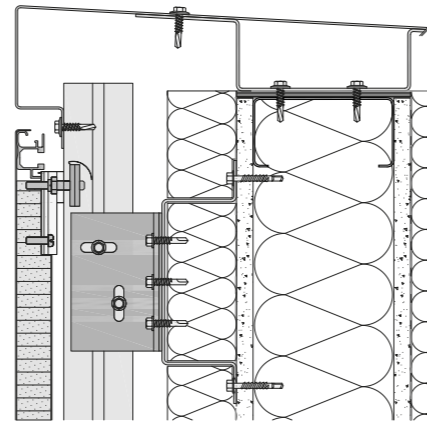

Vertical joint

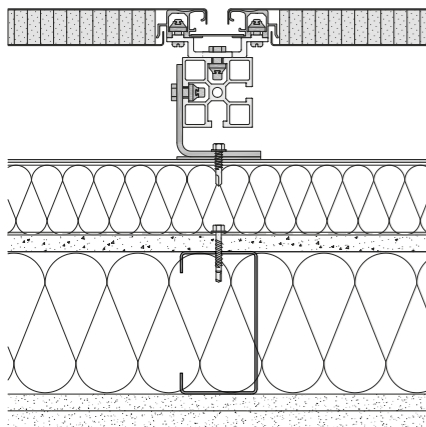

Window jamb

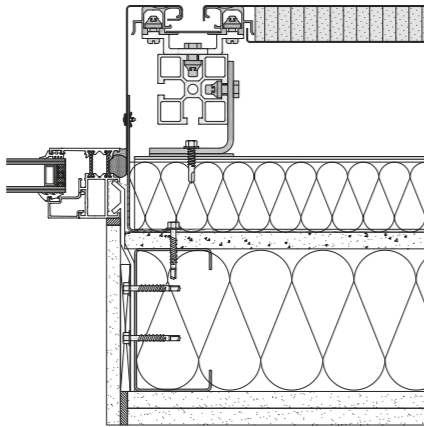

Base

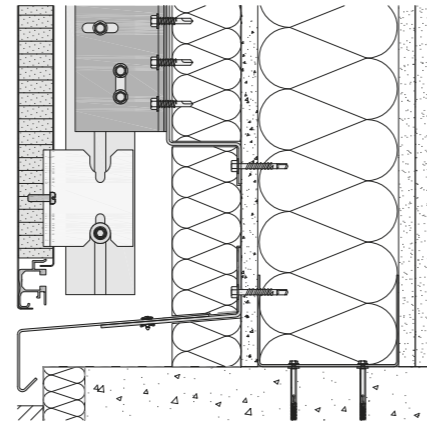

Performance

Fire performance

The Proteus HR system meets the requirements of BS476: Parts 6 and 7, therefore achieving a Class O rating as classified by building regulations. Any specified firebreaks would be installed by a Proteus approved contractor. A non-standard A2 System is also available, which meets the requirements of the London Underground Code of Practice; the product is listed on the London Underground Register of approved products as 'Proteus HR LU'. For further information, please contact our technical department.

Weather testing

The Proteus HR system has successfully undergone testing in accordance with CWCT Standard Test Methods for walls with ventilated rainscreens. The Proteus HR system passed the water tightness testing using dynamic pressure and wind resistance testing for both Safety (3.6kn/m²) and Serviceability (2.4kn/m²).

Maintenance

Proteus HR is a low-maintenance system that can be easily cleaned with water and a mild detergent. Subject to material finish there may be no requirement for a scheduled cleaning regime.

Durability

The Proteus HR system uses various metals as a finished face; these metals all have their own intrinsic durability properties and will be determined by geographical location, local environment and possibly the colour selected. The Proteus HR system has been tested in accordance with BRE Digest 346, Part 7, wind speeds for serviceability and fatigue assessment.

The panel system was cycled through 6450 pressure loads ranging from 960 pascals to 2400 pascals without any deformation, damage or degradation, therefore demonstrating the durability of the Proteus HR system over a 50-year life cycle.

Proteus HR span performance

Proteus HR panel span performance

The data shown here is a guide to the span performance of Proteus HR panels. The spans are based upon 25mm honeycomb.

All dimensions stated are in millimetres.

*Honeycomb thickness can be altered to suit project specific span requirements.

Single Span - Maximum Panel Span in mm

Front Skin Material	0.8 kN/m ²	1.0 kN/m ²	1.2 kN/m ²	1.4 kN/m ²	1.6 kN/m ²	1.8 kN/m ²
0.7mm Copper	2200	2200	2000	1800	1800	1800
0.7mm Stainless Steel	2800	2600	2400	2200	2200	2000
0.7mm Zinc	2200	2000	1800	1800	1800	1600
1.0mm Aluminium	2200	2000	1800	1800	1600	1600

Double Span - Maximum Panel Span in mm

Front Skin Material	0.8 kN/m ²	1.0 kN/m ²	1.2 kN/m ²	1.4 kN/m ²	1.6 kN/m ²	1.8 kN/m ²
0.7mm Copper	3000	2800	2600	2600	2400	2400
0.7mm Stainless Steel	3600	3400	3200	3000	2800	2800
0.7mm Zinc	3000	2800	2600	2400	2400	2200
1.0mm Aluminium	2800	2800	2400	2400	2400	2200

Proteus HR 50mm x 50mm mullion span performance

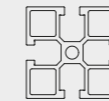

The data shown here is a guide to the span performance of Proteus HR 50mm x 50mm aluminium mullion.

All dimensions stated are in millimetres.

Single Span - Allowable wind loads in kN/m², maximum deflection L/200

Vertical span of mullion		1800	1600	1400	1200	1000	0.8	0.7	0.6	0.5	0.5	0.4	0.4	0.3	0.3	0.3	
		1800	1600	1400	1200	1000	0.8	0.7	0.6	0.5	0.5	0.4	0.4	0.3	0.3	0.3	
Horizontal spacing of mullion	1000	1200	1400	1600	1800	2000	2200	2400	2600	2800	3000	1.1	1.2	1.3	1.4	1.5	1.6
	1200	1400	1600	1800	2000	2200	2400	2600	2800	3000	0.9	1.0	1.1	1.2	1.3	1.4	
	1400	1600	1800	2000	2200	2400	2600	2800	3000	0.7	0.8	0.9	1.0	1.1	1.2		
	1600	1800	2000	2200	2400	2600	2800	3000	0.6	0.7	0.8	0.9	1.0	1.1			
	1800	2000	2200	2400	2600	2800	3000	0.5	0.6	0.7	0.8	0.9	1.0				

Double Span - Allowable wind loads in kN/m², maximum deflection L/200

Vertical span of mullion		2200	2000	1800	1600	1400	1.1	0.9	0.8	0.7	0.6	0.6	0.5	0.5	0.4	0.4	0.4
		2200	2000	1800	1600	1400	1.1	0.9	0.8	0.7	0.6	0.6	0.5	0.5	0.4	0.4	0.4
Horizontal spacing of mullion	1000	1200	1400	1600	1800	2000	2200	2400	2600	2800	3000	1.5	1.6	1.7	1.8	1.9	2.0
	1200	1400	1600	1800	2000	2200	2400	2600	2800	3000	1.2	1.3	1.4	1.5	1.6	1.7	
	1400	1600	1800	2000	2200	2400	2600	2800	3000	1.0	1.1	1.2	1.3	1.4	1.5		
	1600	1800	2000	2200	2400	2600	2800	3000	0.8	0.9	1.0	1.1	1.2	1.3			
	1800	2000	2200	2400	2600	2800	3000	0.7	0.8	0.9	1.0	1.1	1.2				

Proteus HR 100mm x 50mm mullion span performance

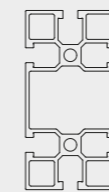

The data shown here is a guide to the span performance of Proteus HR 100mm x 50mm aluminium mullion.

All dimensions stated are in millimetres.

Single Span - Allowable wind loads in kN/m², maximum deflection L/200

Vertical span of mullion		2800	2600	2400	2200	2000	1.6	1.3	1.1	1	0.9	0.8	0.7	0.7	0.6	0.6	0.5
		2800	2600	2400	2200	2000	1.6	1.3	1.1	1	0.9	0.8	0.7	0.7	0.6	0.6	0.5
Horizontal spacing of mullion	1000	1200	1400	1600	1800	2000	2200	2400	2600	2800	3000	2.5	2.7	2.9	3.1	3.3	3.5
	1200	1400	1600	1800	2000	2200	2400	2600	2800	3000	2.1	2.3	2.5	2.7	2.9	3.1	
	1400	1600	1800	2000	2200	2400	2600	2800	3000	1.8	2.0	2.2	2.4	2.6	2.8		
	1600	1800	2000	2200	2400	2600	2800	3000	1.5	1.7	1.9	2.1	2.3	2.5			
	1800	2000	2200	2400	2600	2800	3000	1.3	1.5	1.7	1.9	2.1	2.3				

Double Span - Allowable wind loads in kN/m², maximum deflection L/200

Vertical span of mullion		3600	3400	3200	3000	2800	1.8	1.5	1.3	1.1	0.9	0.8	0.8	0.7	0.7	0.6	0.6
		3600	3400	3200	3000	2800	1.8	1.5	1.3	1.1	0.9	0.8	0.8	0.7	0.7	0.6	0.6
Horizontal spacing of mullion	1000	1200	1400	1600	1800	2000	2200	2400	2600	2800	3000	2.5	2.7	2.9	3.1	3.3	3.5
	1200	1400	1600	1800	2000	2200	2400	2600	2800	3000	2.1	2.3	2.5	2.7	2.9	3.1	
	1400	1600	1800	2000	2200	2400	2600	2800	3000	1.8	2.0	2.2	2.4	2.6	2.8		
	1600	1800	2000	2200	2400	2600	2800	3000	1.5	1.7	1.9	2.1	2.3	2.5			
	1800	2000	2200	2400	2600	2800	3000	1.3	1.5	1.7	1.9	2.1	2.3				

Materials and finishes

Please note that all colours shown are representative in print process, we recommend that you request a swatch sample from our sales department for an accurate representation.

All logos and trade names remain the property of their respective owners.

Copper & copper alloys

TECU®

The rich diversity of the TECU range of copper and copper-alloy materials allows unparalleled variety and high-quality aesthetics for architecture.

Material width: 670, 1000mm
Max panel width: 630, 960mm



Stainless steel



Stainless steel offers the ideal combination of high strength, excellent corrosion resistance and a modern, progressive image.

Material width: 1000, 1250, 1500mm
Max panel width: 960, 1210, 1460mm

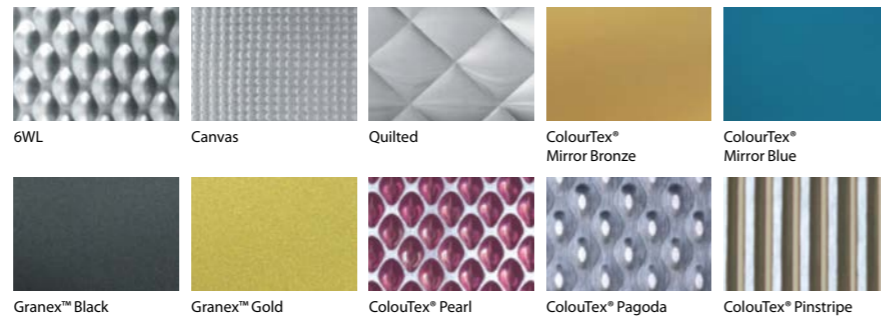

Zinc



Building owners and architects are increasingly turning to zinc for its long, maintenance-free life and adaptability to various design styles ranging from traditional to modern.

Material width: 670, 1000mm
Max panel width: 630, 960mm

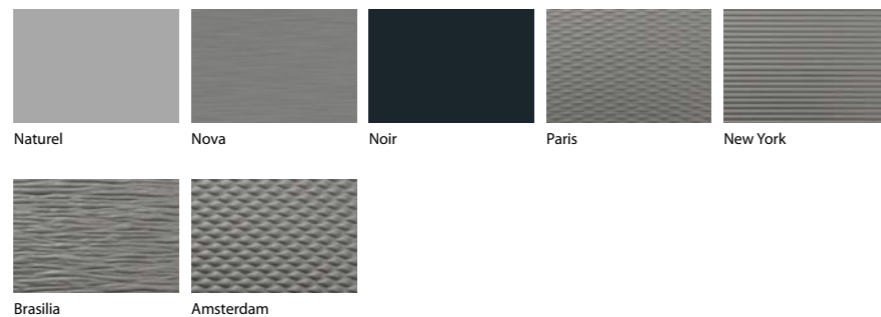

Anodised aluminium



Anodising enhances and reinforces the natural beauty of aluminium to create a living surface constantly interacting with the natural or artificial light playing across its surface.

Material width: 1000, 1250, 1500, 2000mm
Max panel width: 960, 1210, 1460, 1960 mm



Pre coated and post coated aluminium

Aluminium, with its distinctive contemporary look, can be post coated in any RAL colour and can be prefinished with unique coating formulations offering long-term performance.

Material width: 1000, 1250, 1500mm
Max panel width: 960, 1210, 1460mm



Pre coated and post coated steel

Steel, with its distinctive contemporary look, can be post coated in any RAL colour and can be prefinished with unique coating formulations offering long-term performance.

Material width: 1000, 1250mm
Max panel width: 960, 1210mm

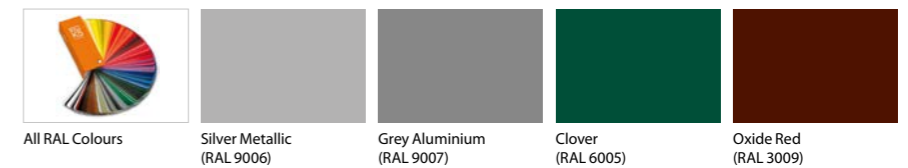

Weathering steel

Weathering steel offers superior resistance to atmospheric corrosion because of its protective layer, which develops and regenerates continuously as the material is weathered.

Material width: 1000, 1250mm
Max panel width: 960, 1210mm



Please contact Proteus regarding requests for non-standard material widths. Panel lengths of upto 7.2m can be manufactured from coil material however please note some materials are only available in standard sheet lengths.

The finishes shown are a small sample of the available finishes, please see our website for more www.proteusfacades.com

Project services

Consultation

We offer a full consultation service at the early stages of your project, helping you choose the right specification for your scheme and your budget. Our technical department will provide design assistance to ensure compliance and provide a cost-effective solution. As part of the consultation process we can provide standard product samples and can also assist in the development of project specific prototypes, mock ups and project samples to allow you to visualise your perfect Proteus solution.

Estimating

Our experienced estimators can advise on all aspects of the Proteus system and its application, along with detailed cost information in a timely manner. We can provide robust budget estimates for cost plan purposes through to full project take-offs with detailed quotations taking into account all Proteus materials required to complete your project.

Manufacture

All Proteus products are custom manufactured in our UK factory for each individual project. All elements are supplied pre-finished, ready for on-site installation. Our manufacturing operation features state-of-the-art production facilities, backed up by an uncompromising approach to quality control. Our CNC-driven process offers full flexibility in terms of dimensions.

Proteus product range



The Proteus AR system consists of a range of continuous and modular louvres and modular brise soleil. The system is manufactured from aluminium and is fixed to the Proteus carrier system via an ingenious plastic clip system.



The Proteus CX system is a honeycomb panel system that utilises the Proteus aluminium support and fixing system. The face of the panel has a 3.5mm thick ceramic layer, giving the appearance of large-format stone/ceramic panels.



The Proteus SC system is a single-skin panel system that can be provided in all metal finishes both solid, perforated and mesh. The panel system uses the same aluminium support system as Proteus.



The Proteus GL system is a honeycomb panel system that utilises the Proteus aluminium support and fixing system. The face of the panel has a 4mm to 6mm thick back painted glass layer. The system is a creative, cost effective and energy efficient method of applying glass to buildings.

Quality assurance

We manufacture all our products to the highest quality standard, operating a BSI accredited Quality Management System in compliance with the requirements of ISO 9001. Our products are manufactured from the highest-quality materials from our approved supply chain, using state-of-the-art production equipment which is rigorously controlled through inspection and testing at each production stage. Our products are designed and manufactured in accordance with all related and prevailing standards.



FS 581452

Environment

We operate a highly efficient manufacturing facility that operates a BSI accredited Environmental Management System in compliance with the requirements of ISO 14001. We are constantly focused on increasing our understanding and improving the sustainability of our products. By continually improving our products and processes we aim to recover and recycle all our waste. Using the most precise material optimisation software, we ensure our yield of finished product from raw materials is maximised, thus reducing our waste. As a direct result, we reduce our carbon-dioxide emissions, reducing our environmental footprint and that of our customers. Our systems can be simply disassembled on site and transported to be reused or recycled.



EMS 581453

Health and safety

Our Business Delivery is managed efficiently and responsibly through the practice of our BSI accredited Occupational Health & Safety Management System in compliance with the requirements of ISO 18001. Through our Management System we promote a safe and healthy working environment by providing a framework that allows our organisation to identify and control its health and safety risks, reduce the potential for accidents, ensure legislative compliance and improve overall performance.



OHS 581454

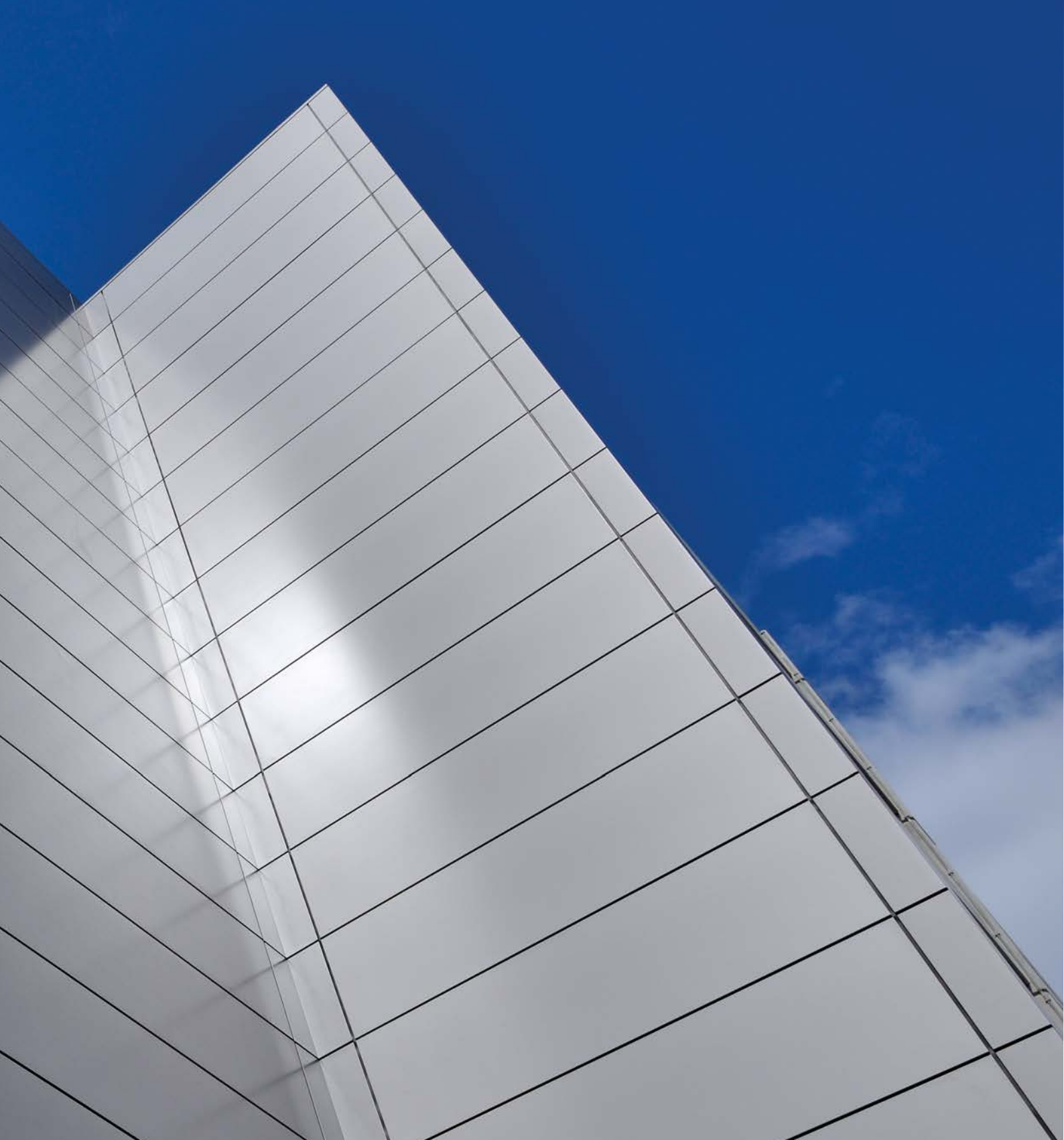

SIG Trading Ltd T/A Proteus Facades
East Lancashire Road, Kirkby, Merseyside L33 7TU
Telephone +44 (0)151 545 5075 www.proteusfacades.com



FS 581452



EMS 581453



OHS 581454

© 2016 Proteus Engineered Facades

The details and information contained in this publication are correct at the point of going to press. Proteus reserves the right to change details and specifications without prior notice. No responsibility is assumed for errors or misinterpretations resulting from the information contained in this publication. Typical construction details are illustrative only and no liability is accepted. Latest information is available at www.proteusfacades.com

Part of **SIG** plc