

EW1
1:20 @ A1

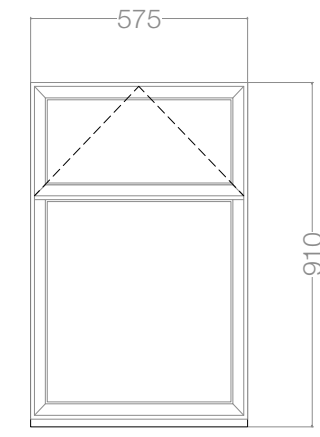

EW2
1:20 @ A1

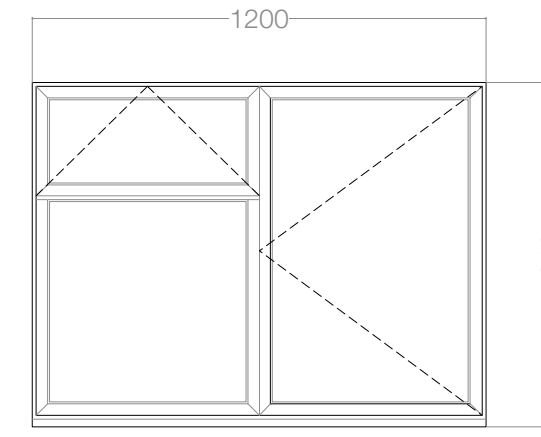

EW3
1:20 @ A1

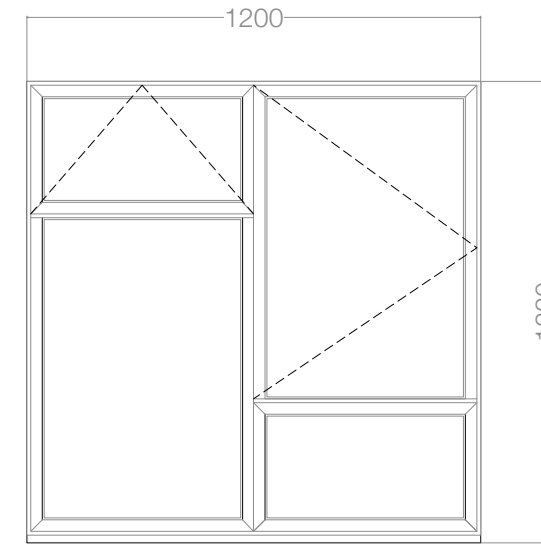

EW4
1:20 @ A1

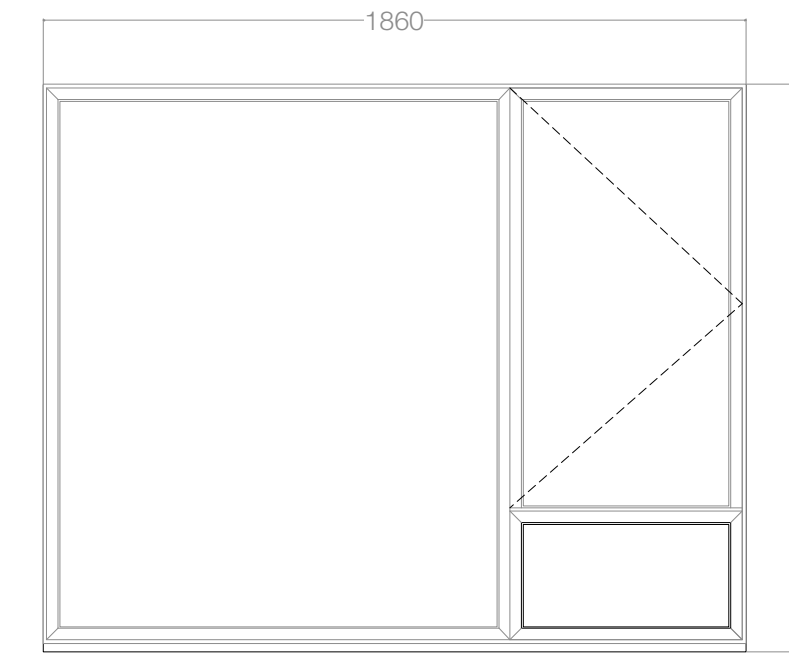

EW5
1:20 @ A1

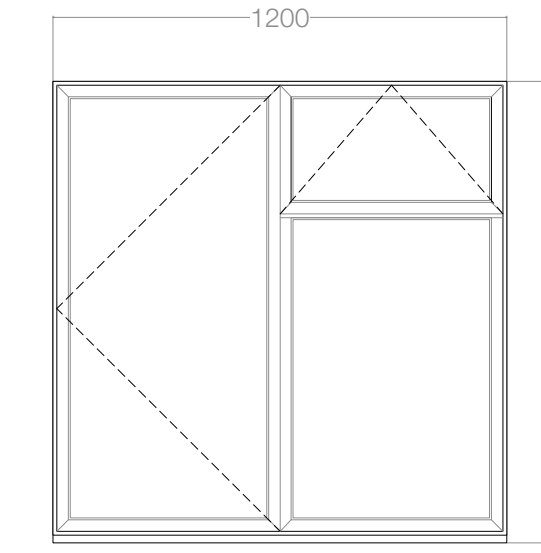

EW6
1:20 @ A1

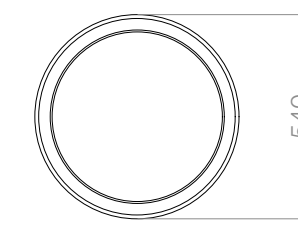

EW7
1:20 @ A1

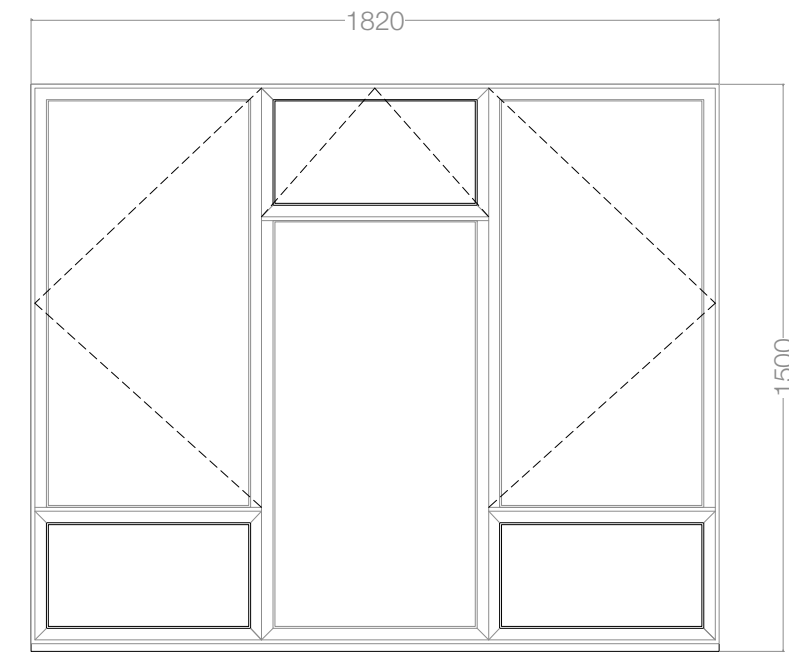

EW8
1:20 @ A1

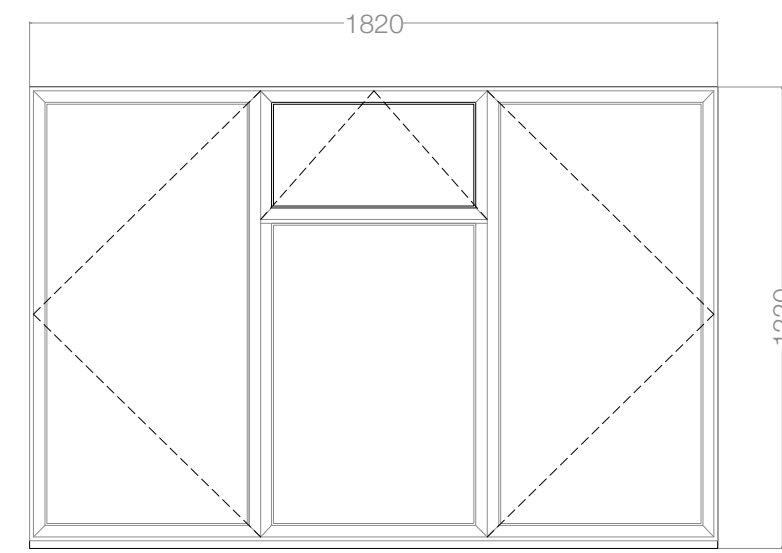

EW9
1:20 @ A1

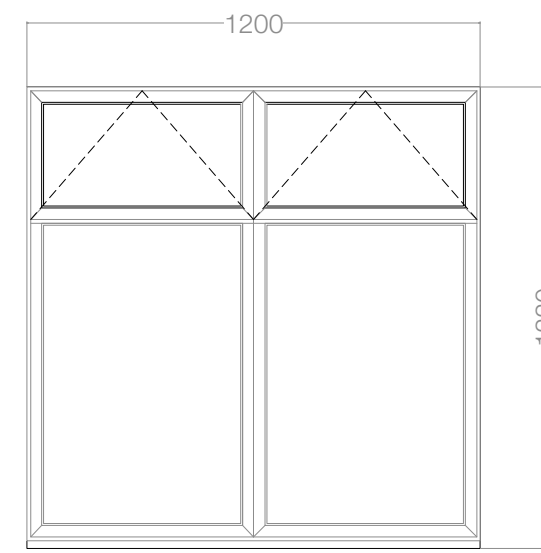

EW10
1:20 @ A1

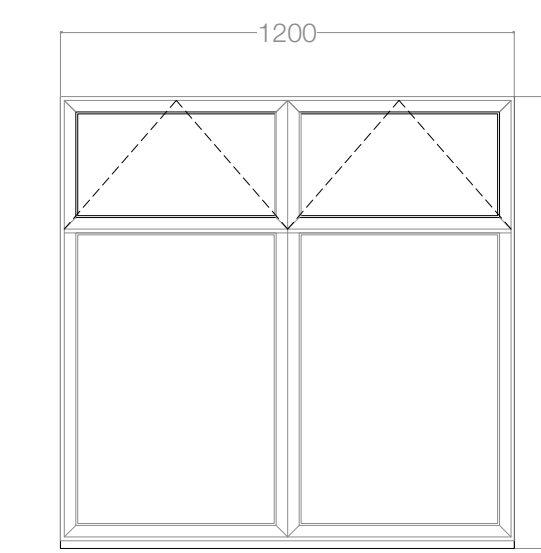

EW11
1:20 @ A1

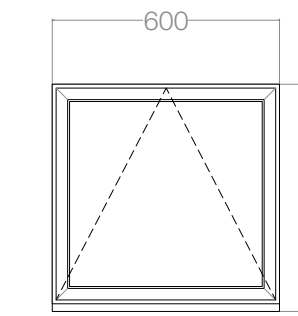

EW12
1:20 @ A1

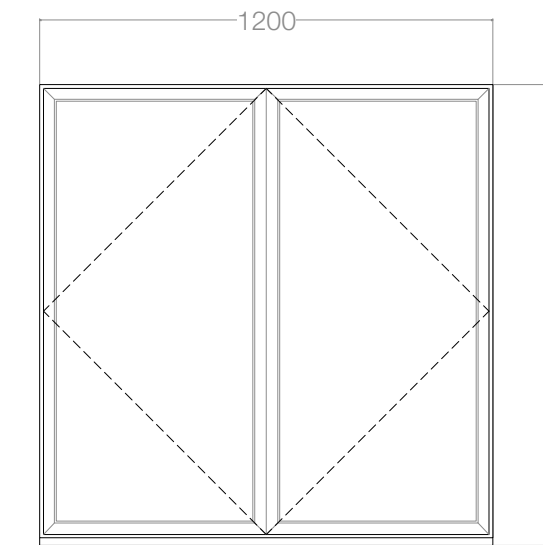

EW13
1:20 @ A1

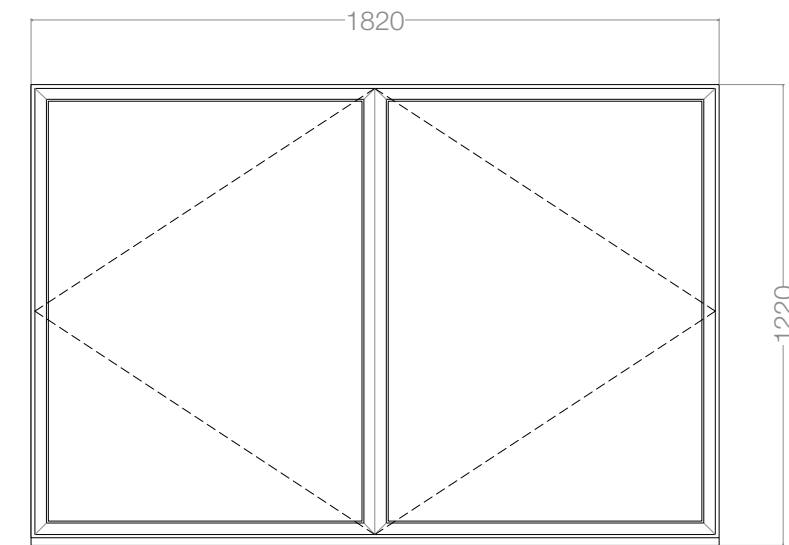

EW14
1:20 @ A1

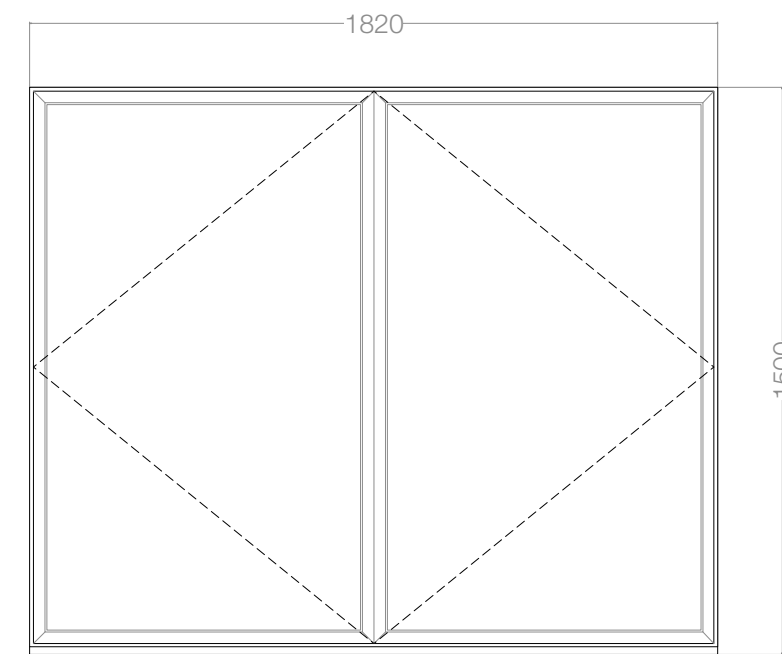

EW15
1:20 @ A1

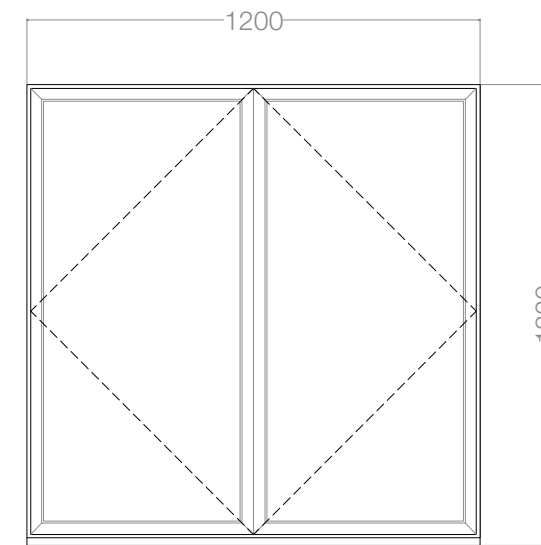

EW16
1:20 @ A1

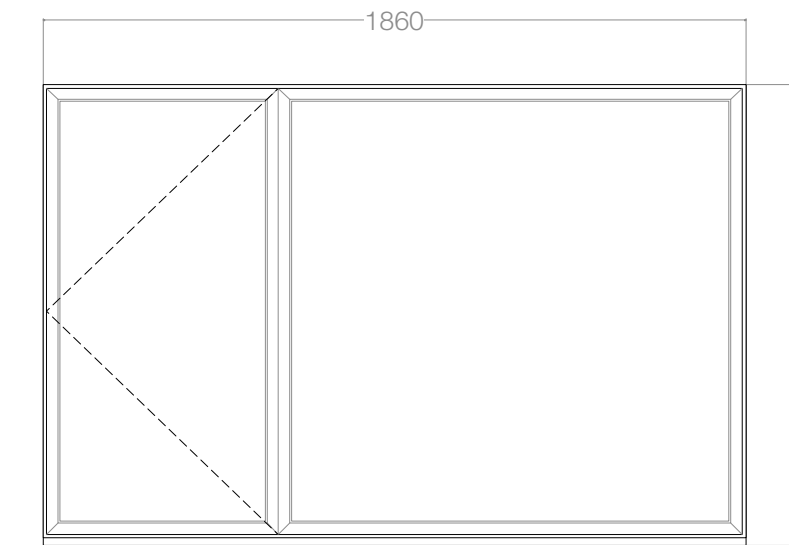

EW17
1:20 @ A1

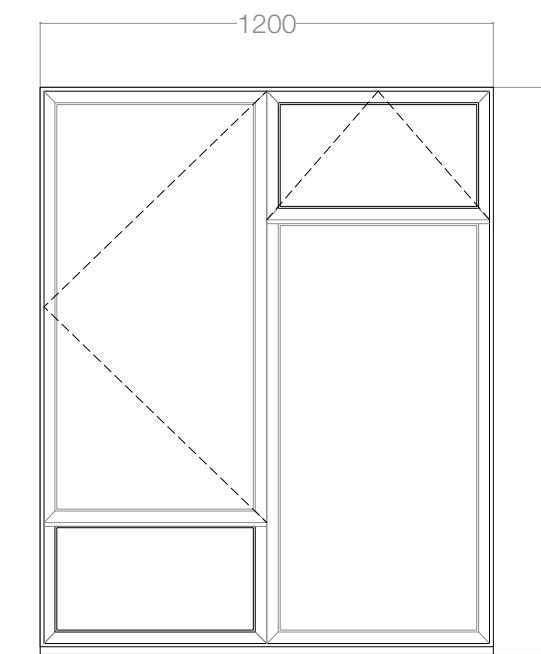

EW18
1:20 @ A1

WINDOW TYPE	DIMENSIONS	QUANTITY	ELEVATION REFERENCE
EW1	1195mm x 1195mm	6	A, L, AA.
EW2	575mm x 910mm	56	B, C, J, K, BB, CC, DD.
EW3	1200mm x 910mm	10	B, C, H, K, V.
EW4	1200mm x 1220mm	24	A, B, C, D, K, M, T.
EW5	1860mm x 1500mm	10	F, G, W, X, Z.
EW6	1200mm x 1220mm	6	W, X, Y, Z.
EW7	540mm Diameter	11	J, K, P, U, CC, DD.
EW8	1820mm x 1500mm	19	Q, R, W, X, Y, Z.
EW9	1820mm x 1220mm	15	Q, R, V, W, X, Y, Z, AA.

WINDOW TYPE	DIMENSIONS	QUANTITY	ELEVATION REFERENCE
EW10	1200mm x 1220mm	10	T, AA.
EW11	1200mm x 1195mm	4	T, V.
EW12	600mm x 600mm	8	T, U.
EW13	1200mm x 1220mm	1	T.
EW14	1820mm x 1220mm	2	Q.
EW15	1820mm x 1500mm	1	Q.
EW16	1200mm x 1220mm	7	C, D, E, G, T.
EW17	1860mm x 1220mm	2	F, G.
EW18	1200mm x 1500mm	29	E, G, H, M, N, W, X, Y.

- Do not scale from this drawing.
- Any discrepancies to be referred to the Architect.
- This drawing is to be read in conjunction with all relevant Specifications and other drawings issued by the Architect, Structural Engineer and other Consultants or Specialists.
- This drawing is copyright and is not to be reproduced in part or whole without prior expressed permission of RRA Architects Ltd.

NOTES:
ALL DIMENSIONS ARE TO STRUCTURAL OPENINGS UNLESS INDICATED OTHERWISE. ALL DIMENSIONS TO BE CHECKED WITH SUPPLIER FOR SPECIFIC OPENING AND INSTALLATION REQUIREMENTS.

ALL WINDOW STRUCTURAL OPENINGS TO BE SITE MEASURED PRIOR TO MANUFACTURING TO ALLOW FOR TOLLERANCES.

TRICKLE VENTS TO EXTERNAL WINDOWS REQUIRED TO MEET BUILDING REGULATIONS.

WINDOW CONVENTION NOTE:
WINDOWS DRAWN TO STANDARD NOTATION WITH CHEVRON POINTING TO HINGED WINDOW/DOOR EDGE.

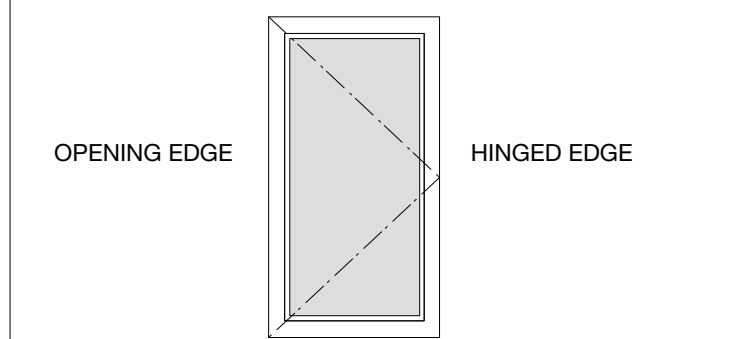

Revision Description	Date	Check	Rev
Change of Drawing Title.	13.09.16	JM	A



RRA Architects Ltd.

10 Barley Mow Passage
London
W4 6PH

T 01432 278707

E info@rra-arch.com

www.rra-arch.com

London T 020 7377 5458 Hereford T 01432 278707 Cheltenham T 01242 269374

Client
Lambert Smith Hampton.

Project
Studholme Court, Finchley Rd., London, NW3 7AE.

Drawing Title
Existing and Proposed Window Types.

Status	Date	Drawn By
Planning.	Aug 2016	JM
Scale	Drawing Number	Revision
1:20 @ A1.	6382(0)002	-