

Prime Aluminium Windows

Horizontal Sliding and Vertical Sliding



Duration Windows

Units 4-5,
Charfleets Road,
Canvey Island,
Essex. SS8 0PQ

t: 01268 681612 (15 lines)
f: 01268 510058
e: sales@duration.co.uk
w: www.duration.co.uk



DURATION WINDOWS

Aluminium Manufacturers Of Distinction Since 1985



Sliding Windows

These vertical or horizontal sliding windows are designed and manufactured in-house by Duration Windows. They are made to measure to your exact size and requirements.

This system is not thermally broken and can be used in any commercial application where a sliding window is needed.

A strong slim-line and economical aluminium system that allows you to complete those jobs where a slim frame is essential.

Horizontal Slider Recommended Sizes

2 Panel		3 Panel		4 Panel	
Min Width	800 mm	Min Width	1200 mm	Min Width	1600 mm
Max Width	3000 mm	Max Width	4500 mm	Max Width	5000 mm
Min Height	400 mm	Min Height	400 mm	Min Height	400 mm
Max Height	2400 mm	Max Height	2400 mm	Max Height	2400 mm

Vertical Slider Recommended Sizes

Recommended Sizes	
Min Width	400 mm
Max Width	1500 mm
Min Height	900 mm
Max Height	2800 mm

Please note
- Maximum panel weights are 50kg 4mm Glass 10.2kg m²
- 6mm Glass 15.2kg m² - All these sizes are recommended sizes and special requests to go under or over these sizes may be possible but will not carry the standard guarantee.



Horizontal Slider

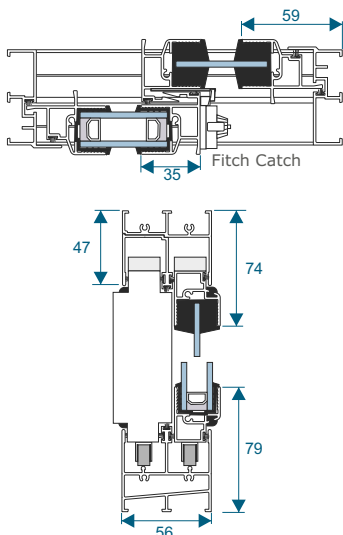

Vertical Slider

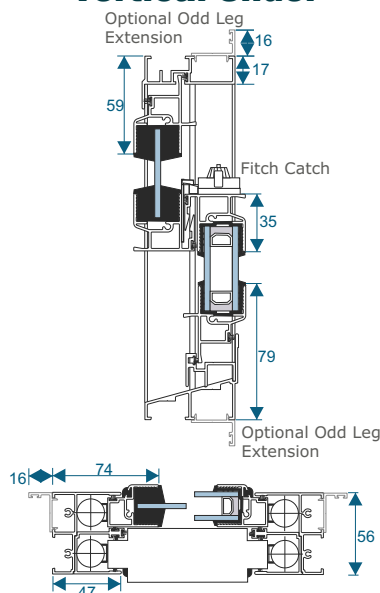

Both a double glazed (20mm) and single glazed (4 - 6.8mm) unit shown.