

General Notes

1. Drawings shall be referred to for structural work only unless otherwise stated and read in conjunction with Architect's, Service Engineer's and Sub-Contractor's drawings.
2. The Contractor shall check all levels and dimensions, any errors or omissions are to be reported at once to the Engineer.
3. For General Notes refer to no. 9100-DRG-99YY-GN002.

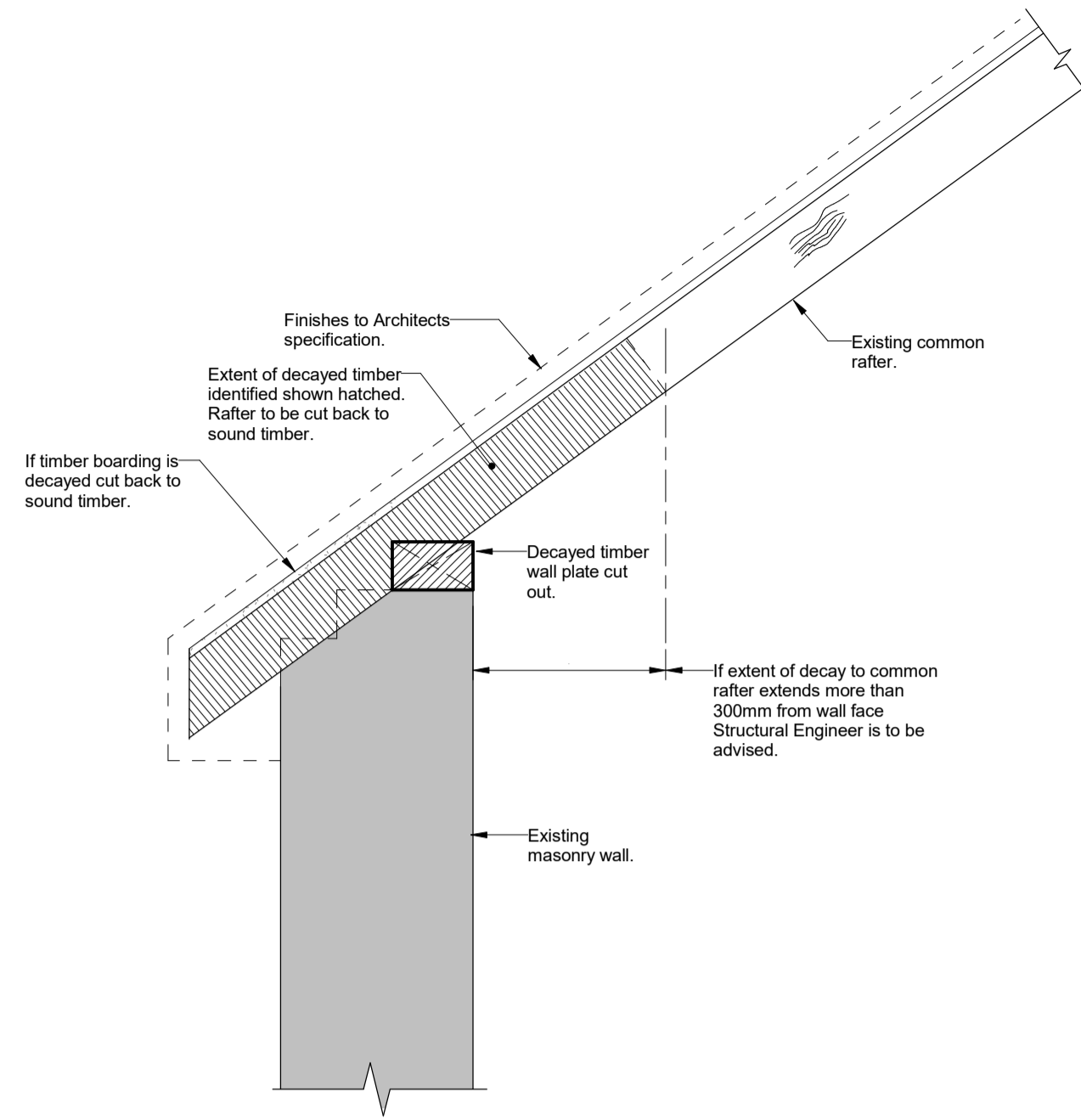

Detail 1: Decayed Common Rafter and Wall Plate
Existing Detail
scale 1 : 10

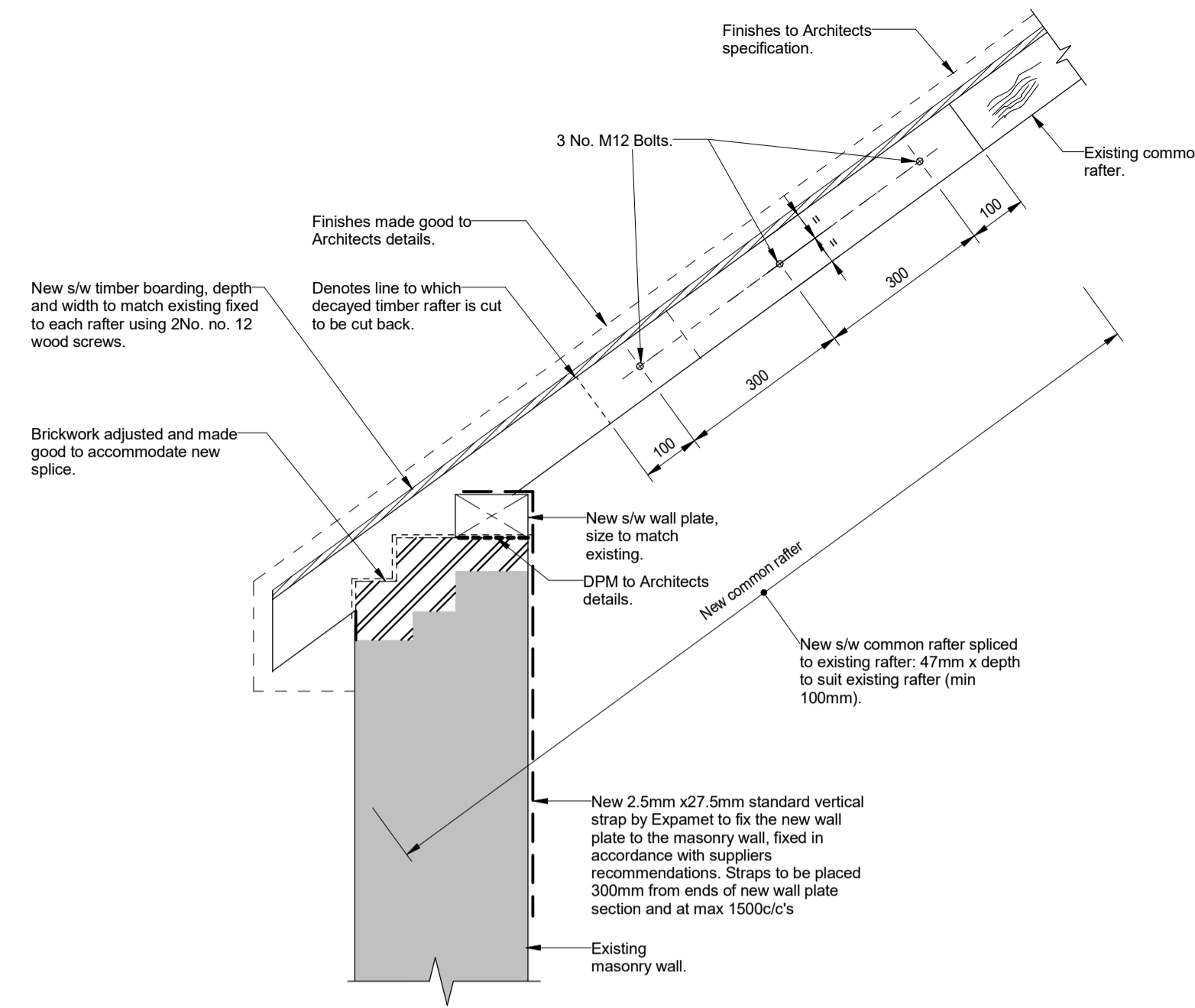

Detail 2: Decayed Common Rafter and Wall Plate
Proposed Splice Detail
scale 1 : 10

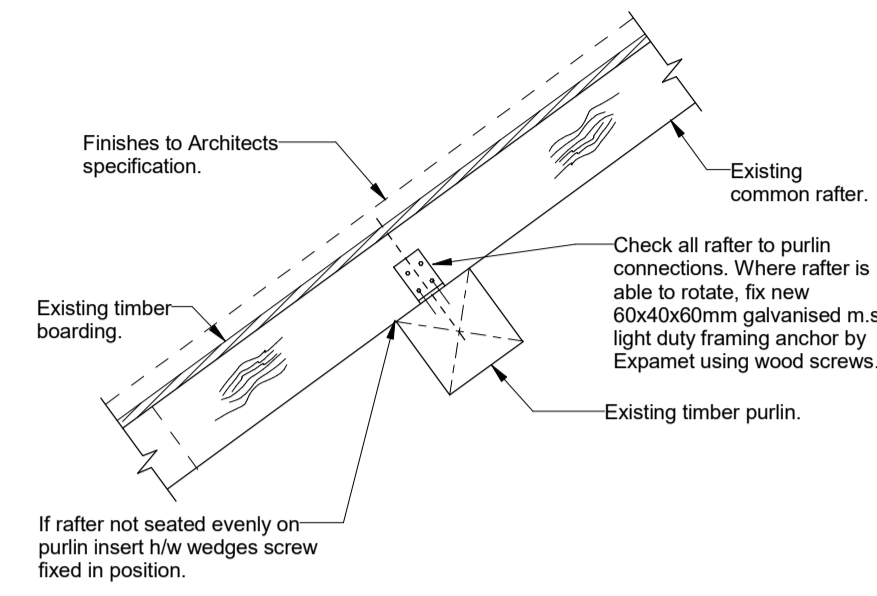

Detail 3: Common Rafter to Purlin Connections
scale 1 : 10

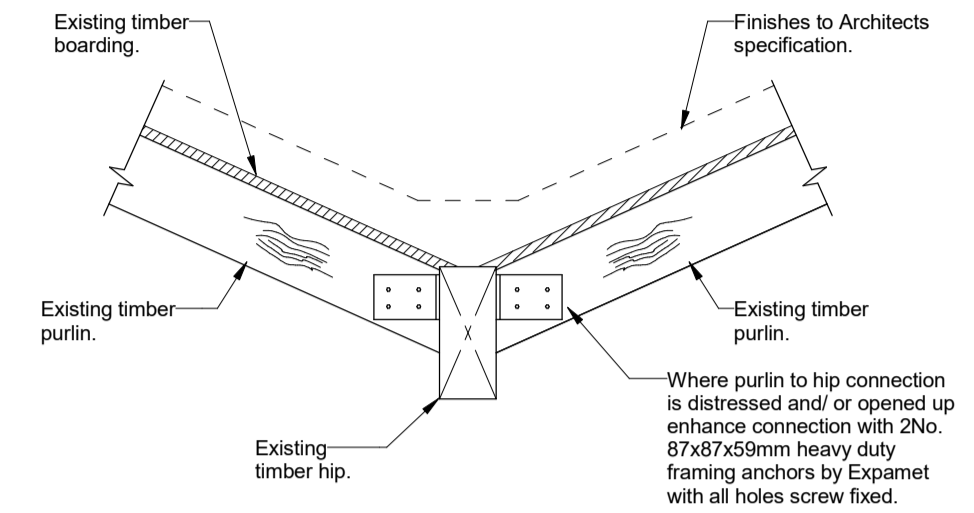

Detail 4: Purlin to Hip Connection Repair
scale 1 : 10

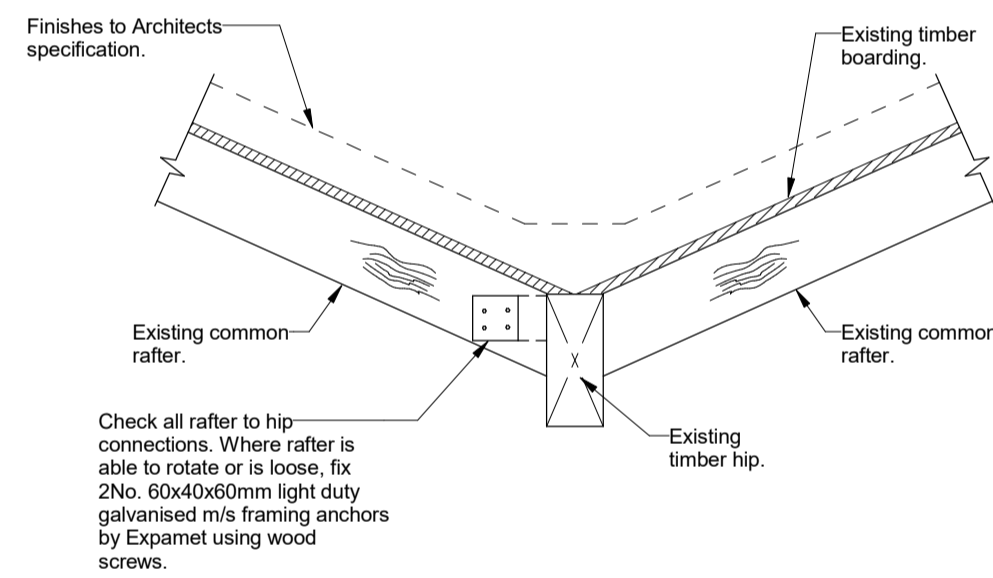

Detail 5: Rafter to Hip Connection Detail
scale 1 : 10

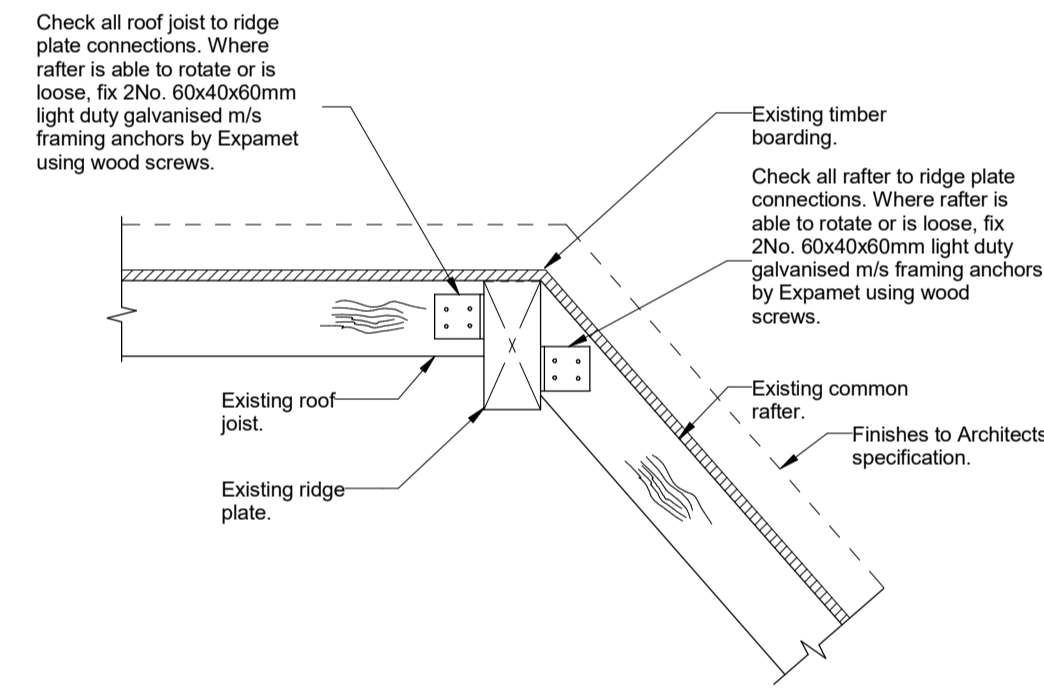

Detail 6: Rafter/Roof Joist to Ridge Plate Detail
scale 1 : 10

REV	DATE	DESCRIPTION	BY	CHKD
-	03.08.16	First Issue	DA	TP

FOR TENDER



TITLE:
Generic Roof Repair Details

PROJECT:
**Project No:11581
Kidderpore Avenue**

SCALE: A1@ As Shown DATE: July 16 DRAWN: DA CHKD: TP

DRG NO. REV.

9100-DRG-00YY-DE011 -

Tully De'Ath consultants
Engineering at its Best

T: 01342 828 000
E: info@tullydeath.com
W: www.tullydeath.com