

FOR NOTES AND DETAILS
REFER TO DRW PA-5815-DT

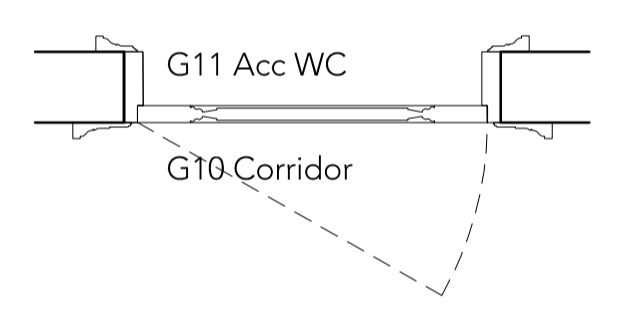
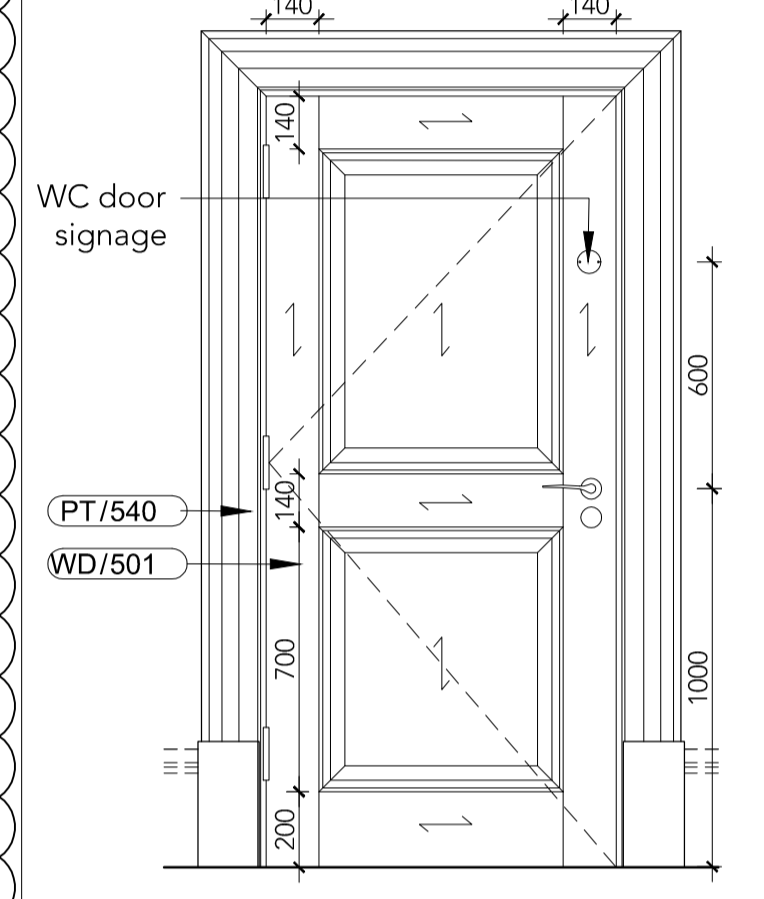
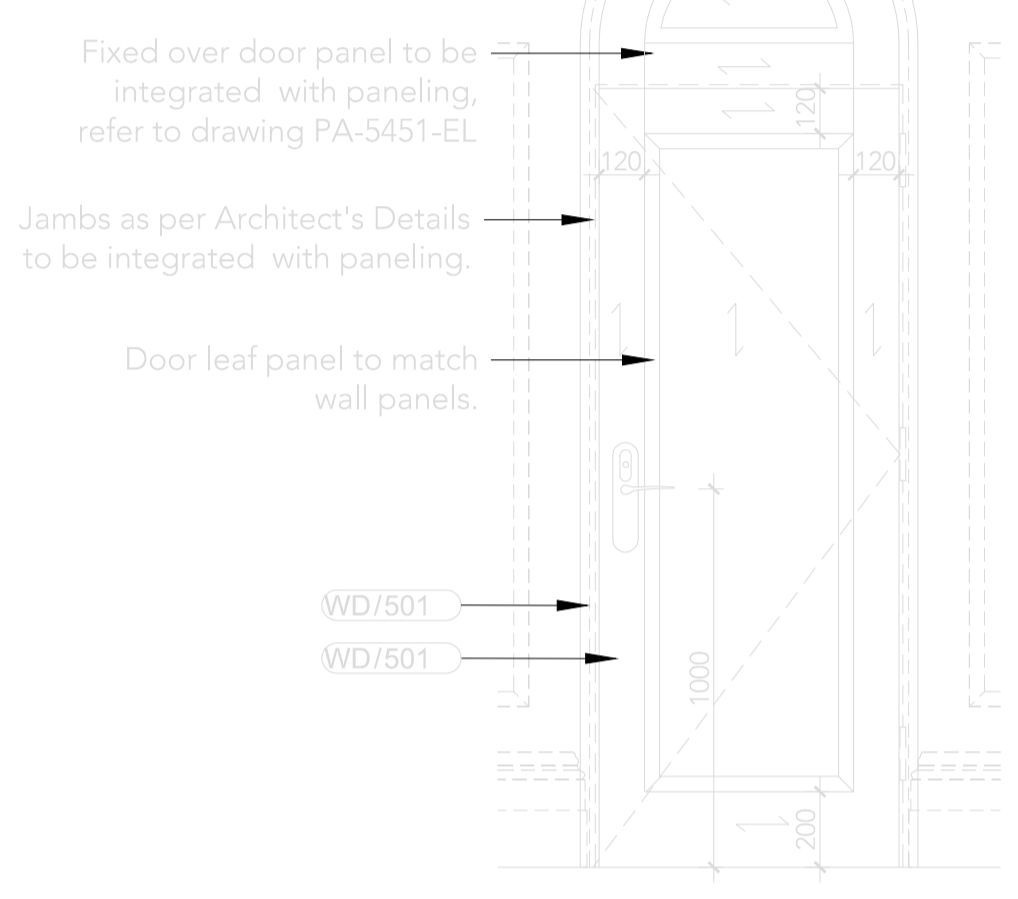
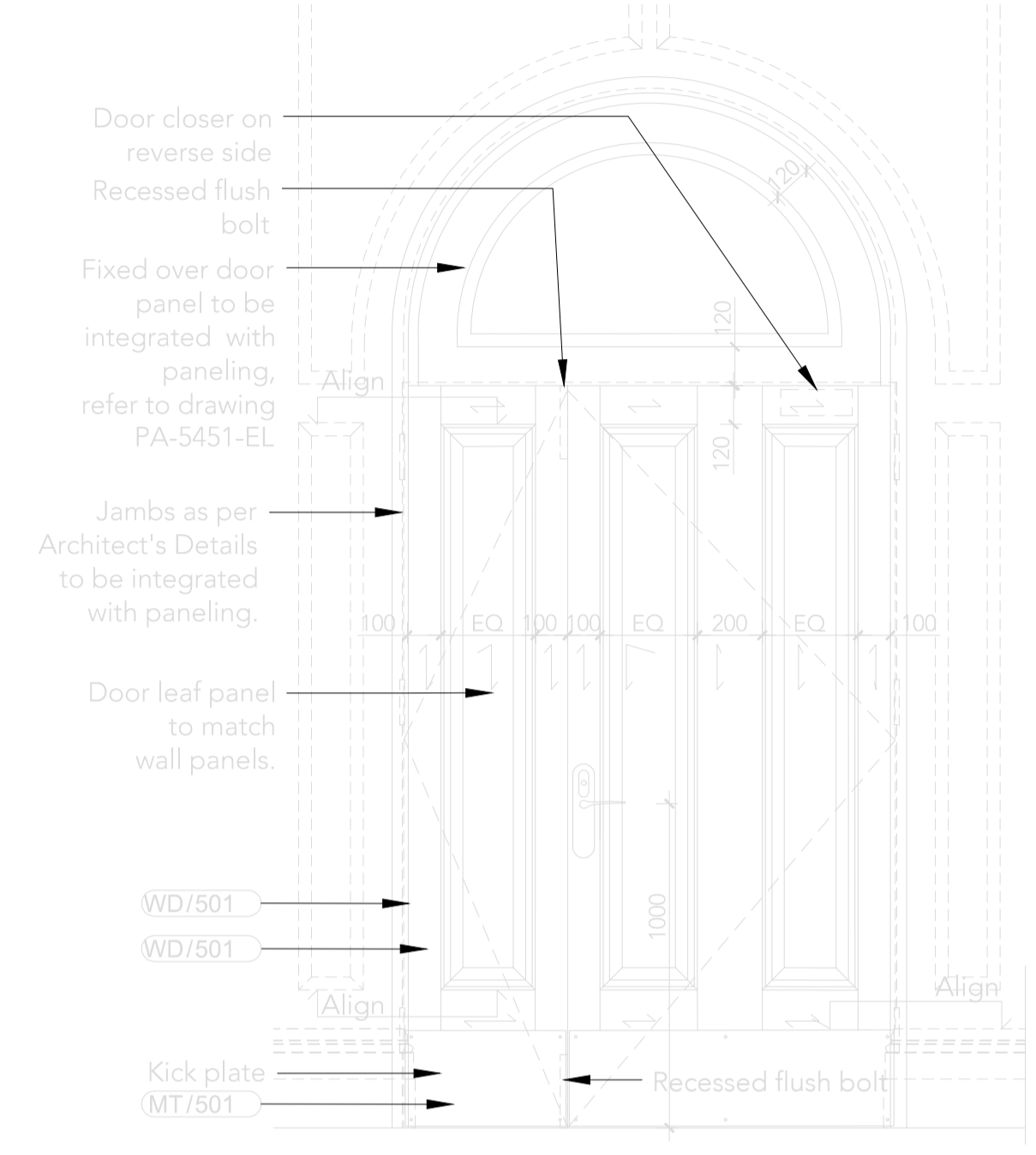
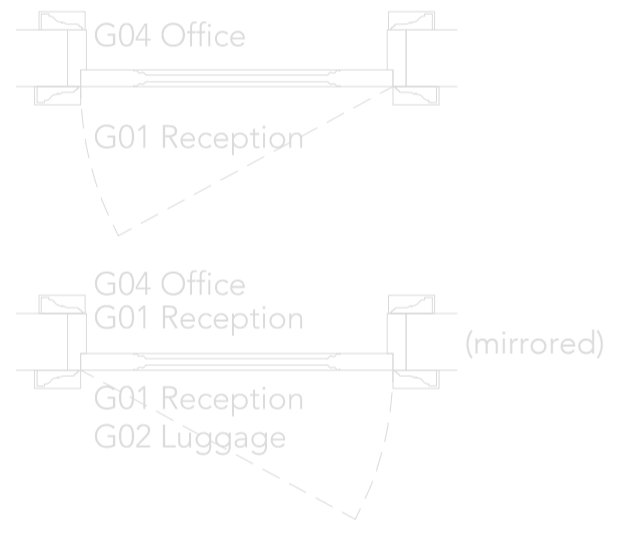
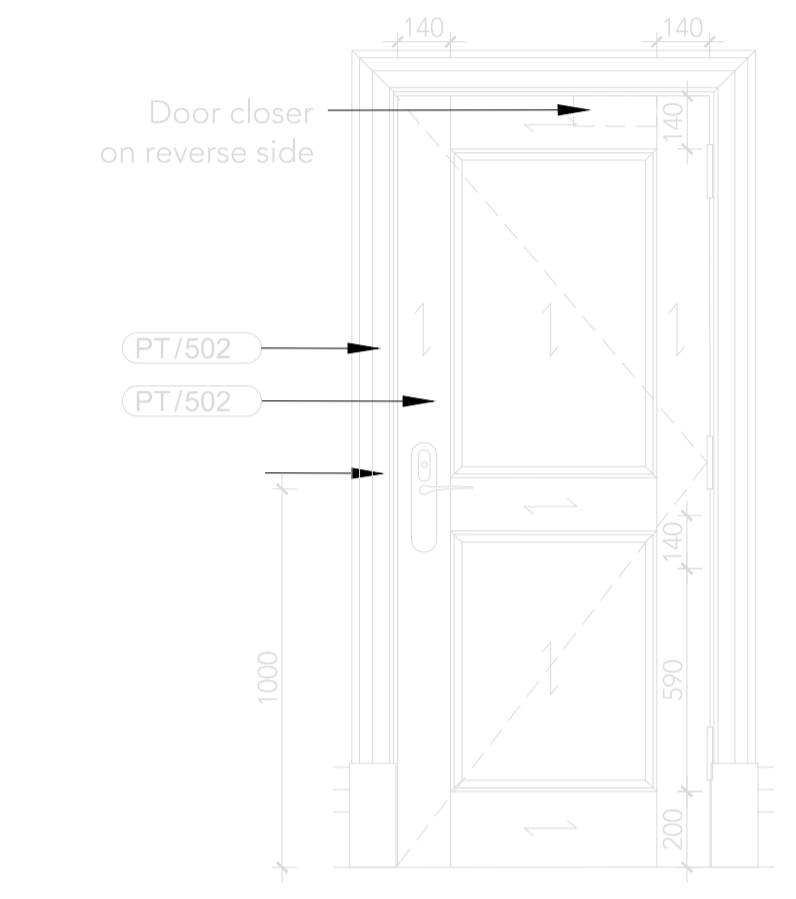
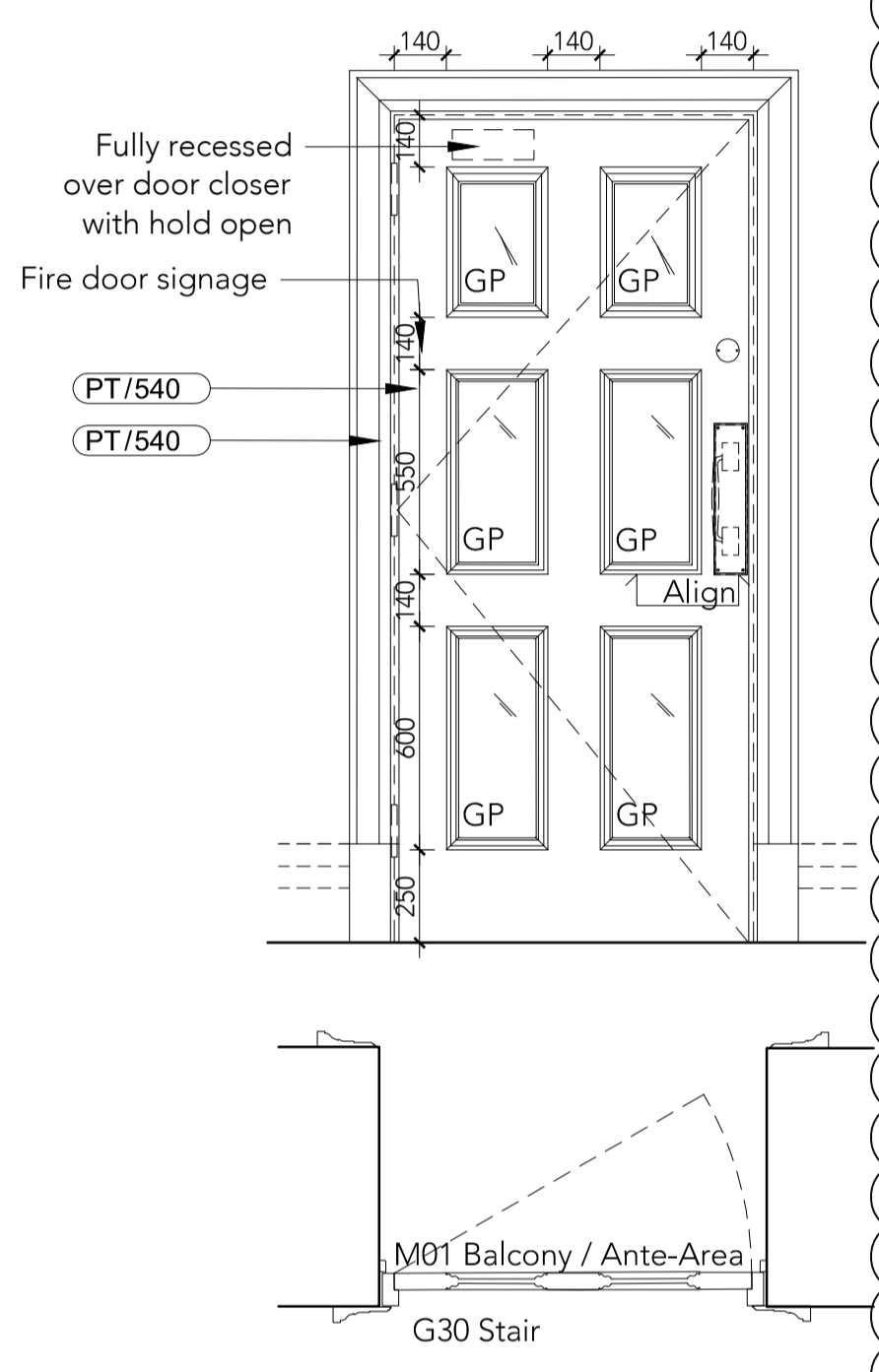

OMIT 2016 03 24

OMIT 2016 03 24

OMIT 2016 03 24

DOOR LEAF TYPE	DL 501
EPR DOOR NO	DM02-01
ARCHITRAVE	AR 503 to M01 Balcony Ante-Room AR504 to G30 Stair 8 AR 505 in jamb reveal
IRONMONGERY SET	PP1.1A Refer to HAF Architectural Hardware Schedule.
NOTES	-

DOOR LEAF TYPE	DL 502
EPR DOOR NO	DG01-01 DG02-02 DG04-01
ARCHITRAVE	AR 504 to G01 Reception Plain to match BoH to G04 Office Plain to match BoH to G02 Luggage
IRONMONGERY SET	S1 & S1.1 Refer to HAF Architectural Hardware Schedule.
NOTES	Key card lock suggested, operator to confirm

DOOR LEAF TYPE	DL 503
EPR DOOR NO	DG02-01
ARCHITRAVE	Plain to match BoH to G04 Office Panel detail to G05 Business Centre
IRONMONGERY SET	S2.1 Refer to HAF Architectural Hardware Schedule.
NOTES	Key card lock suggested, operator to confirm. Flush bolt top and bottom on passive half leaf, finish to match handle.

DOOR LEAF TYPE	DL 504
EPR DOOR NO	DG01-02
ARCHITRAVE	Plain to match BoH to G04 Office Panel detail to G05 Business Centre
IRONMONGERY SET	S1 Refer to HAF Architectural Hardware Schedule.
NOTES	-

DOOR LEAF TYPE	DL 505
EPR DOOR NO	DG11-01
ARCHITRAVE	AR 503 to G10 AR 504 to G11
IRONMONGERY SET	ACC1.1 Refer to HAF Architectural Hardware Schedule.
NOTES	-

FOR NOTES AND DETAILS
REFER TO DRW PA-5815-DT

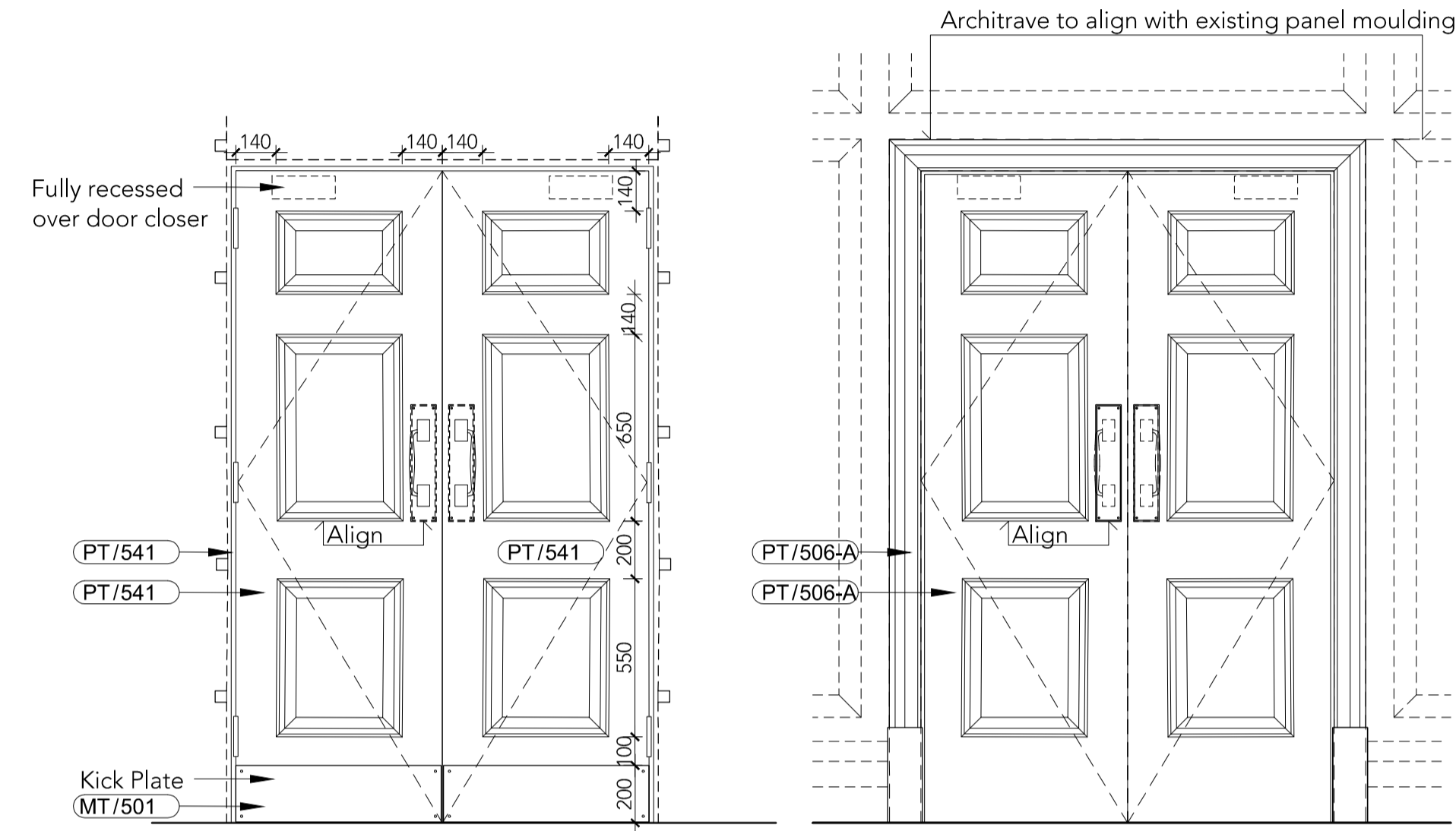
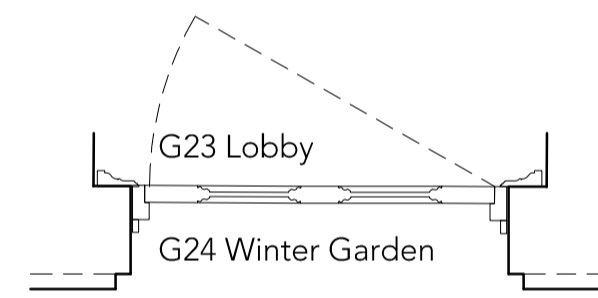
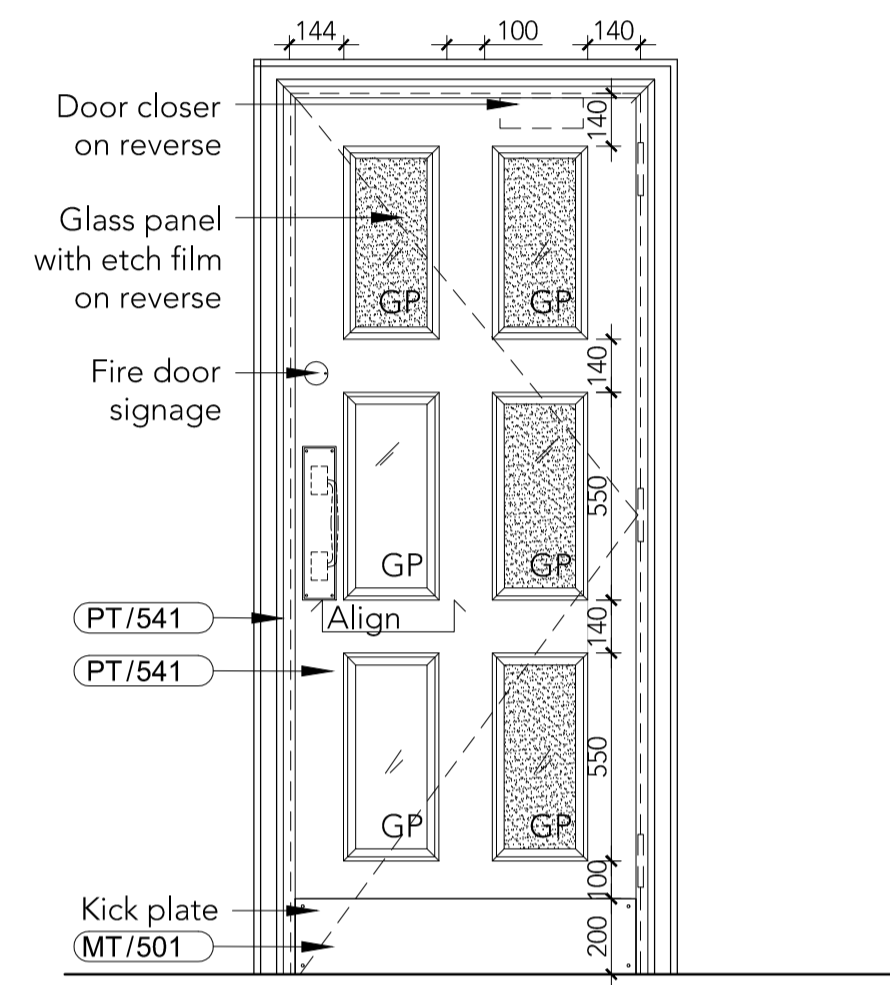
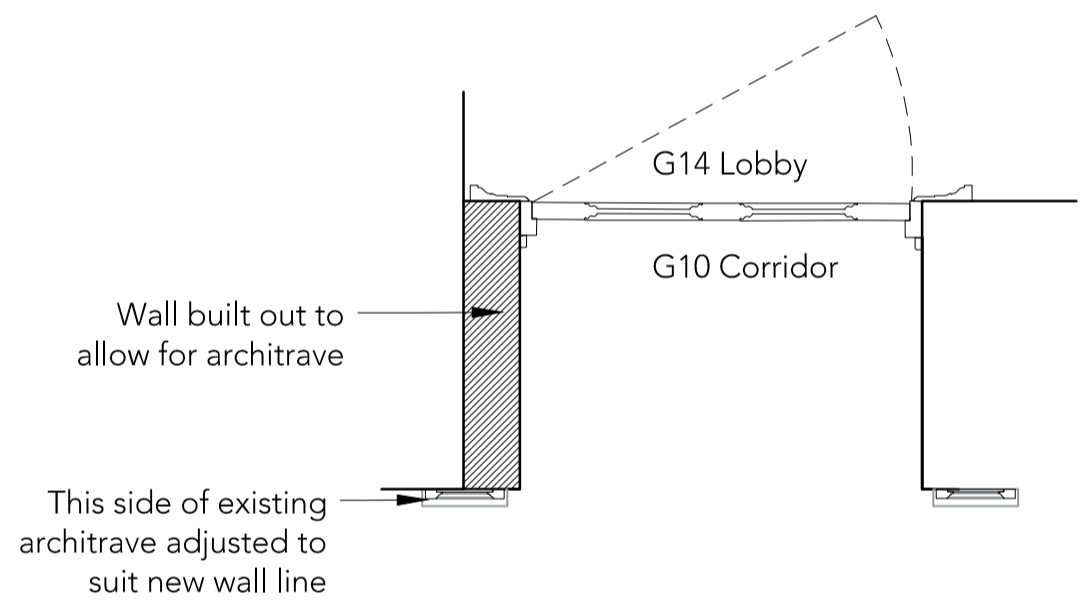
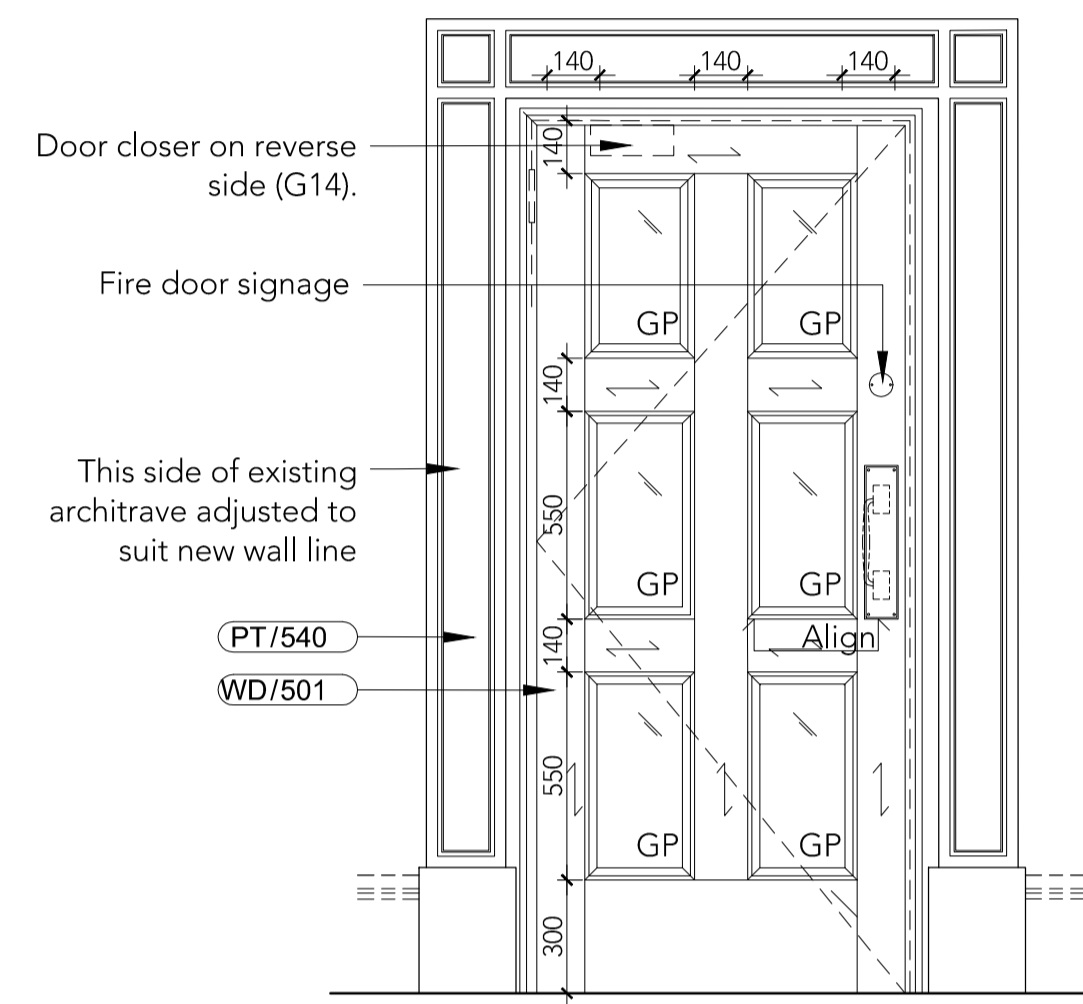

Elevation to G24 Winter Garden

ELEVATION TO G27 BANQUETING HALL

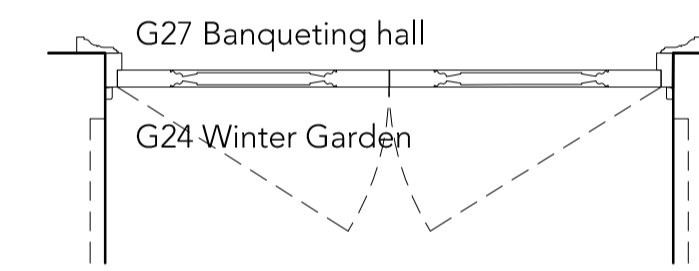

DOOR LEAF TYPE	DL 506
EPR DOOR NO	DG15-01
ARCHITRAVE	Adjusted existing + AR 505 to G10 AR 505 to G14

DOOR LEAF TYPE	DL 507
EPR DOOR NO	DG23-01
ARCHITRAVE	AR 504 to G23 AR 505 to G24

DOOR LEAF TYPE	DL 508
EPR DOOR NO	DG24-02
ARCHITRAVE	AR 504 to G27 AR 505 to G24

IRONMONGERY SET	PP1.3 Refer to HAF Architectural Hardware Schedule.
-----------------	--

IRONMONGERY SET	PP1.9 Refer to HAF Architectural Hardware Schedule.
-----------------	--

IRONMONGERY SET	PP2 Refer to HAF Architectural Hardware Schedule.
-----------------	--

NOTES	
-------	--

NOTES	
-------	--

NOTES	
-------	--

NOTE
DO NOT SCALE FROM THIS DRAWING
THIS IS A CONCEPT DRAWING AND FORMS THE CONCEPT BRIEF TO THE PROJECT ARCHITECT
INFORMATION CONTAINED WITHIN THIS DRAWING IS THE SOLE COPYRIGHT OF TARA BERNERD
& PARTNERS LTD AND IS NOT TO BE REPRODUCED WITHOUT PERMISSION.
TARA BERNERD & PARTNERS ARE TO BE NOTIFIED IMMEDIATELY OF ANY DISCREPANCIES

REVISED A DATE
A Ironmongery codes changed. 24 MAR 2016

FOR NOTES AND DETAILS
REFER TO DRW PA-5815-DT

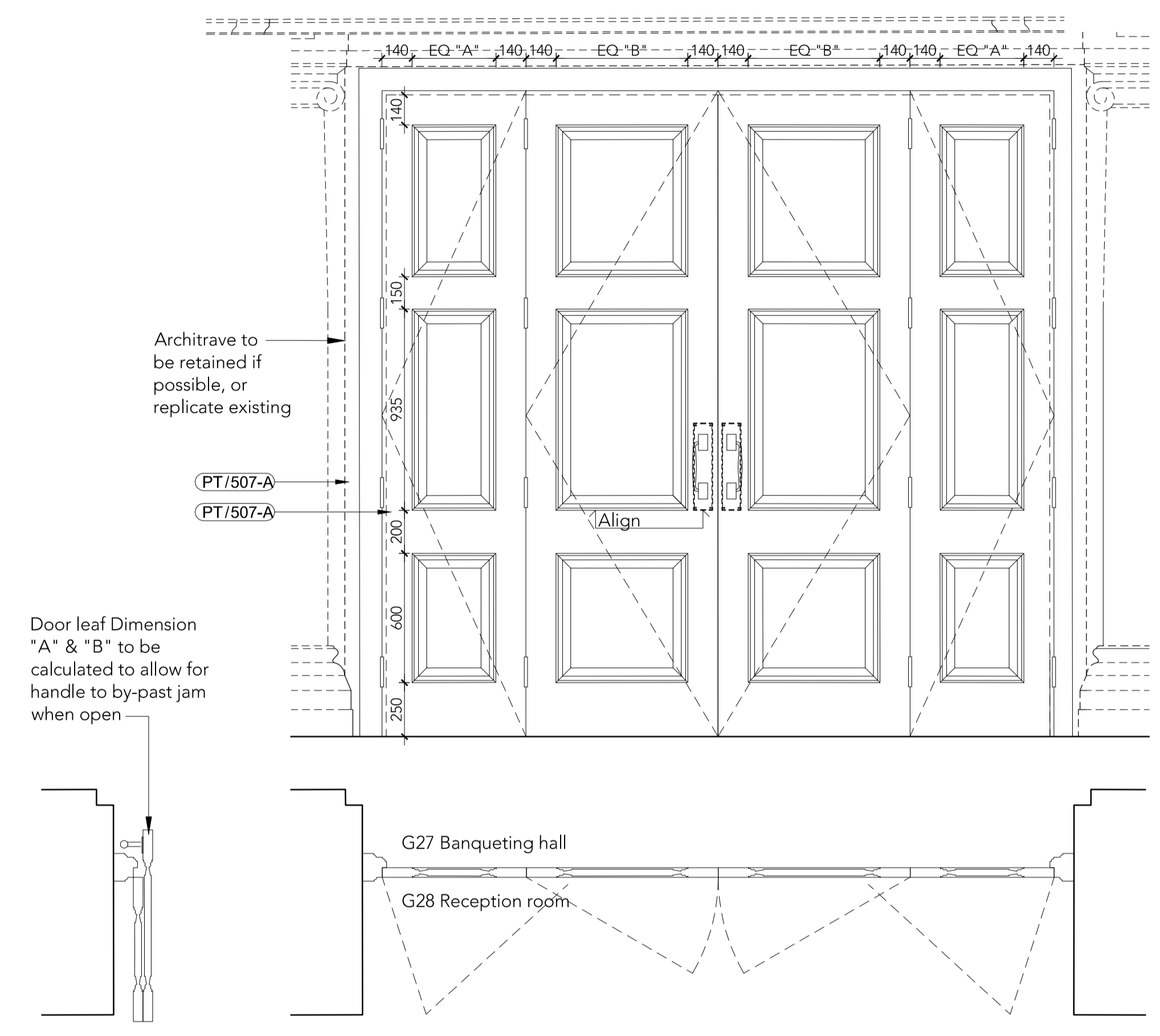
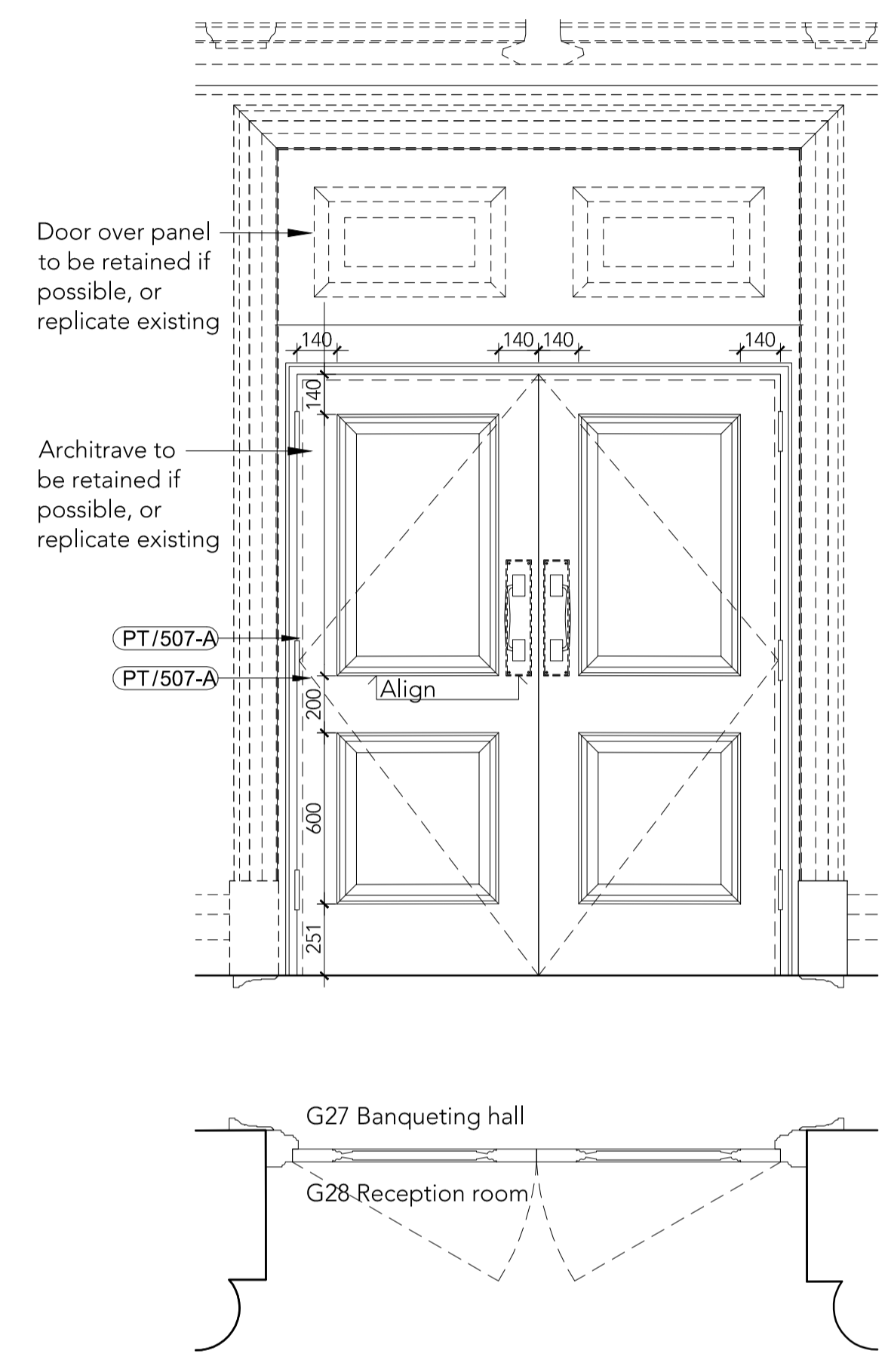

DOOR LEAF TYPE	DL 509
EPR DOOR NO	DG28-01 DG28-03
ARCHITRAVE	To match existing
IRONMONGERY SET	PP2.1 Refer to HAF Architectural Hardware Schedule.
NOTES	

DOOR LEAF TYPE	DL 510
EPR DOOR NO	DG28-02
ARCHITRAVE	To match existing
IRONMONGERY SET	BF4.1 Refer to HAF Architectural Hardware Schedule.
NOTES	

Tara Bernerd & Partners
1 HANS STREET LONDON SW1X 0J T +44(0)20 7245 1658 tarabernerd.com

PROJECT RUSSELL HOTEL
PUBLIC AREAS
DRAWING GROUND FLOOR
DOOR LEAF ELEVATIONS DL509-510

DATE 29 MAY 2015 DRAWN BY TG CHECKED BY TG

STATUS TENDER 2 SCALE @ A1 1:20

DWG NO PA-5802-JN REV A

FOR NOTES AND DETAILS
REFER TO DRW PA-5815-DT

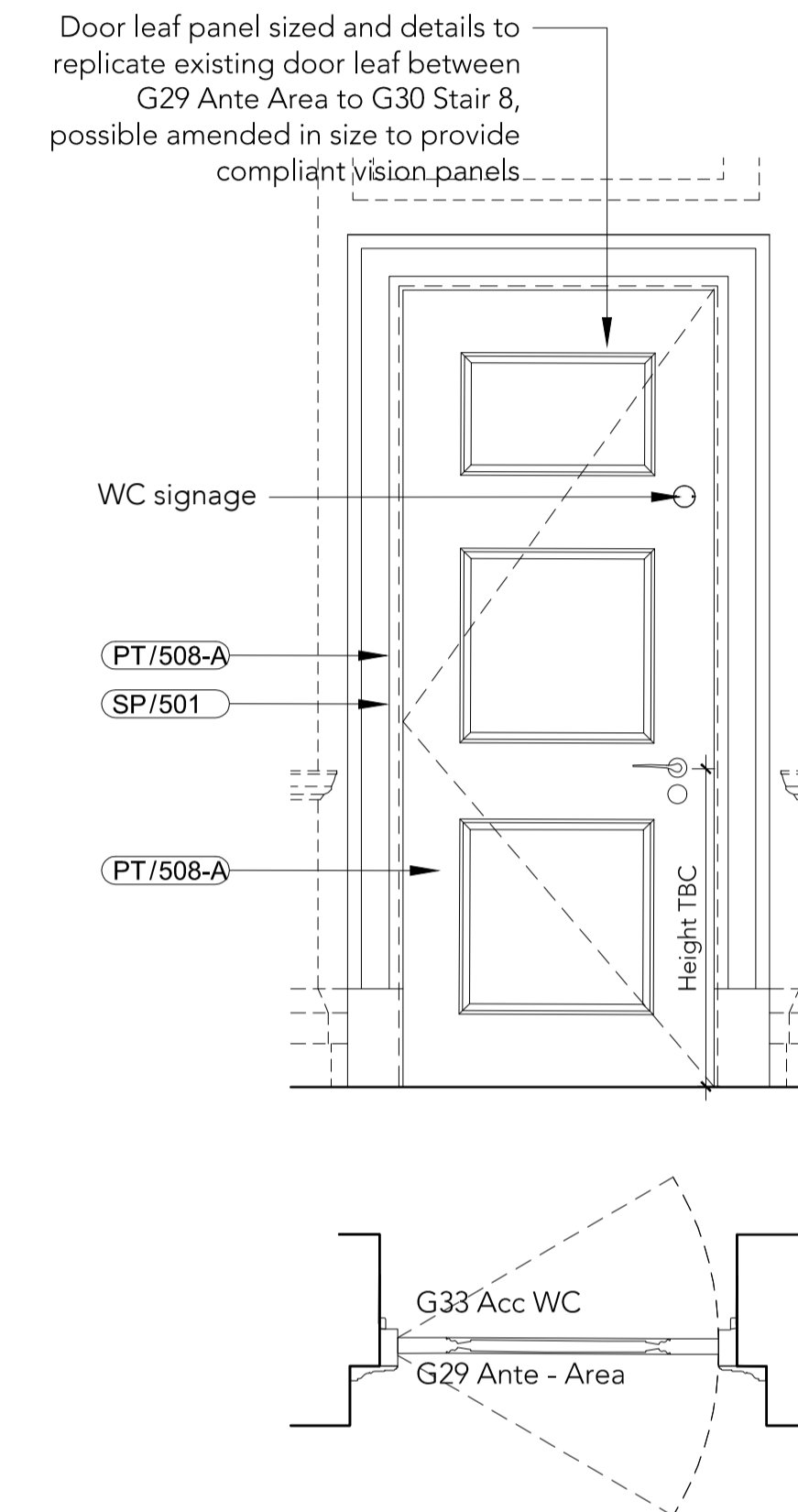
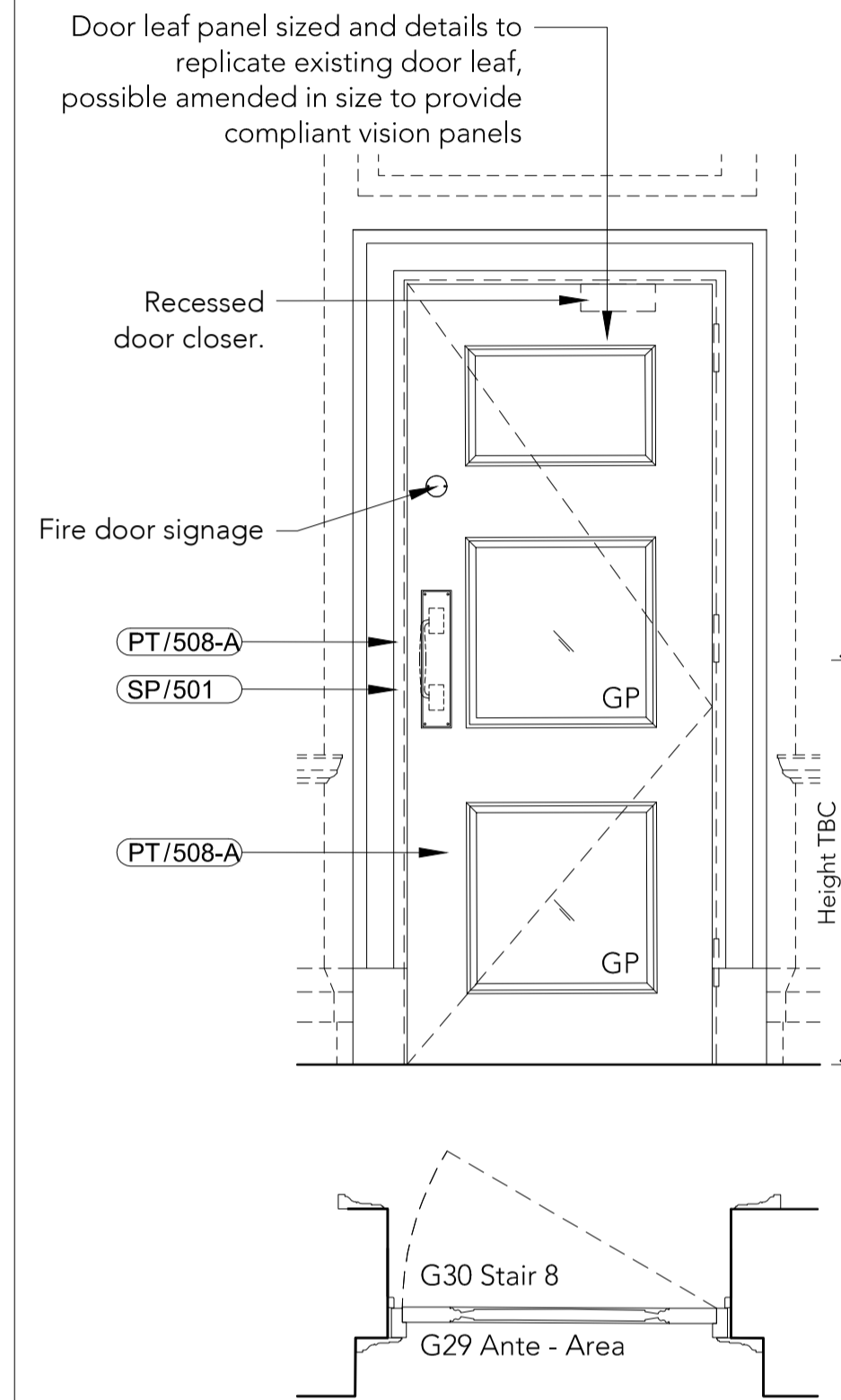
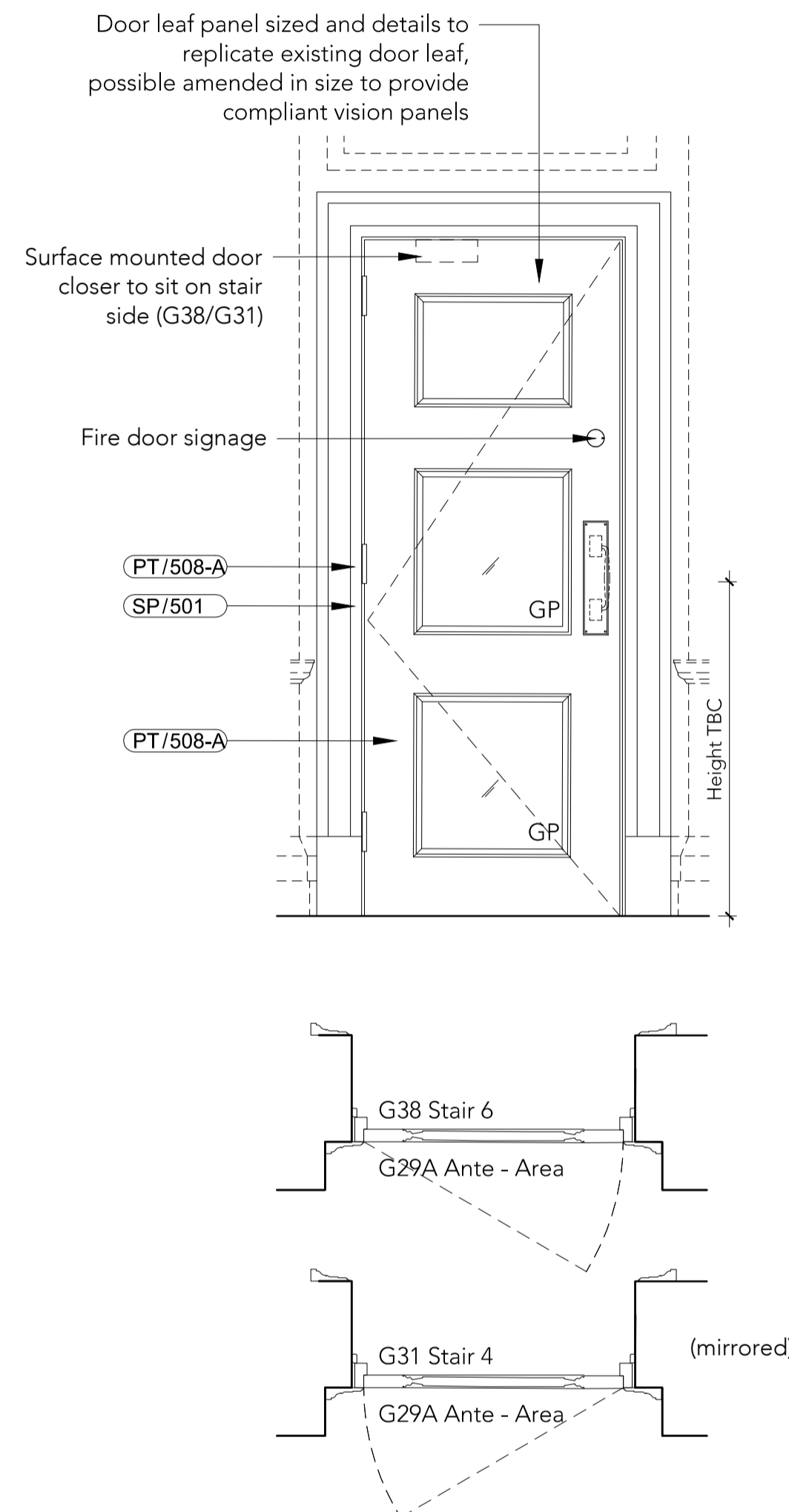
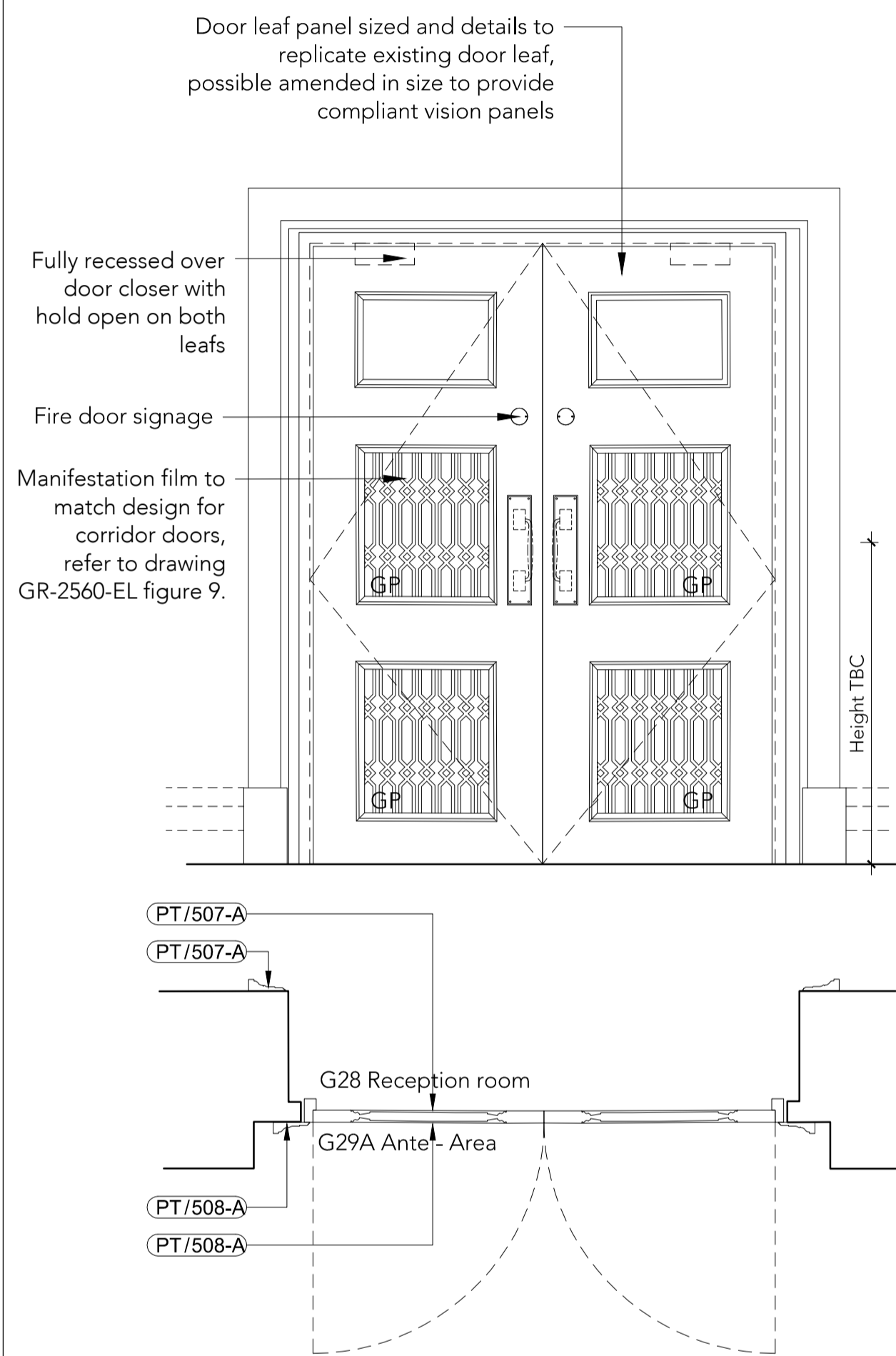

DOOR LEAF TYPE	DL 511
EPR DOOR NO	DG29-01
ARCHITRAVE	To match existing
IRONMONGERY SET	PP2.2 Refer to HAF Architectural Hardware Schedule.
NOTES	Existing leaf to be re - used with new vision panels if possible to upgrade to new fire requirements. Split colour door leaf.

DOOR LEAF TYPE	DL 512
EPR DOOR NO	DG29-02 DG29-03 (mirrored)
ARCHITRAVE	Existing to G29A Ante Area AR 503 on reverse AR 504 at jamb on reverse
IRONMONGERY SET	PP1.1B Refer to HAF Architectural Hardware Schedule.
NOTES	Existing leaf to be re - used with new vision panels if possible to upgrade to new fire requirements.

DOOR LEAF TYPE	DL 513
EPR DOOR NO	DG30-01
ARCHITRAVE	Existing to G29A Ante Area AR 503 on reverse AR 504 at jamb on reverse
IRONMONGERY SET	PP1.1A Refer to HAF Architectural Hardware Schedule.
NOTES	Existing leaf to be re - used with new vision panels if possible to upgrade to new fire requirements.

DOOR LEAF TYPE	DL 514
EPR DOOR NO	DG33-01
ARCHITRAVE	Existing to G29A Ante Area AR 503 on reverse AR 504 at jamb on reverse
IRONMONGERY SET	ACC1 Refer to HAF Architectural Hardware Schedule.
NOTES	Double action pivot door leaf. To have emergency release door stop fitting ER 500, finish to match MT 501.

FOR NOTES AND DETAILS
REFER TO DRW PA-5815-DT

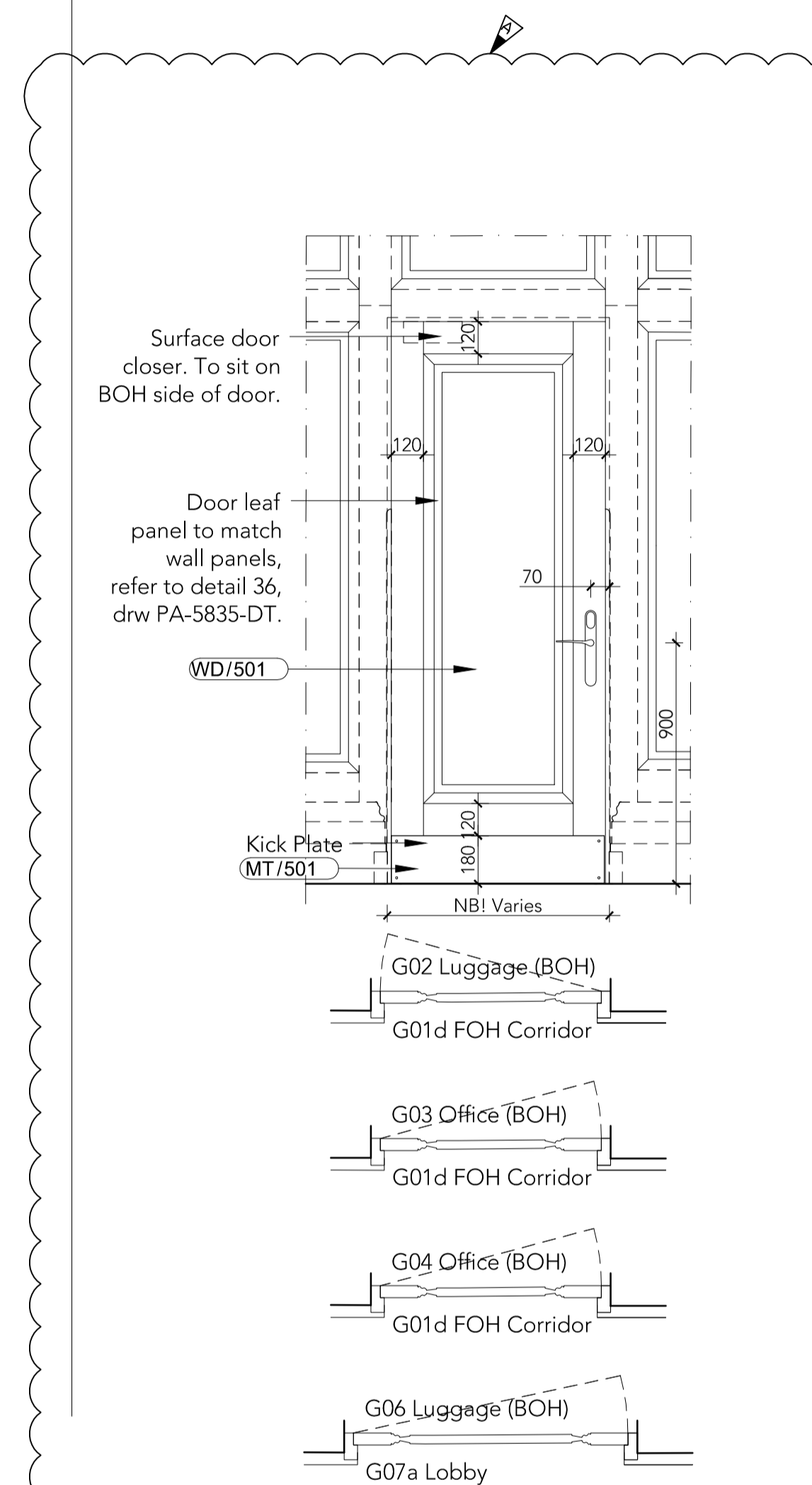
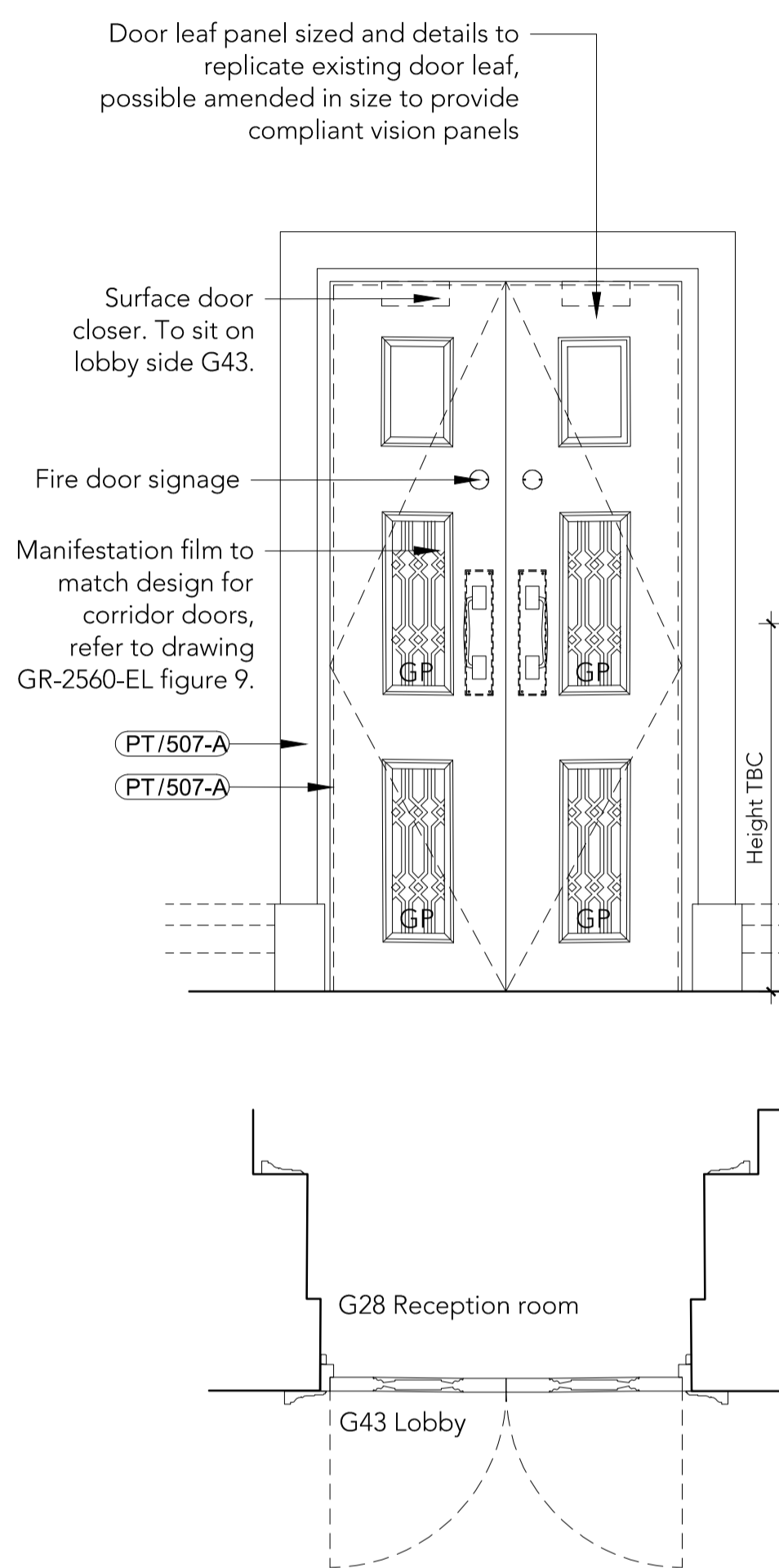
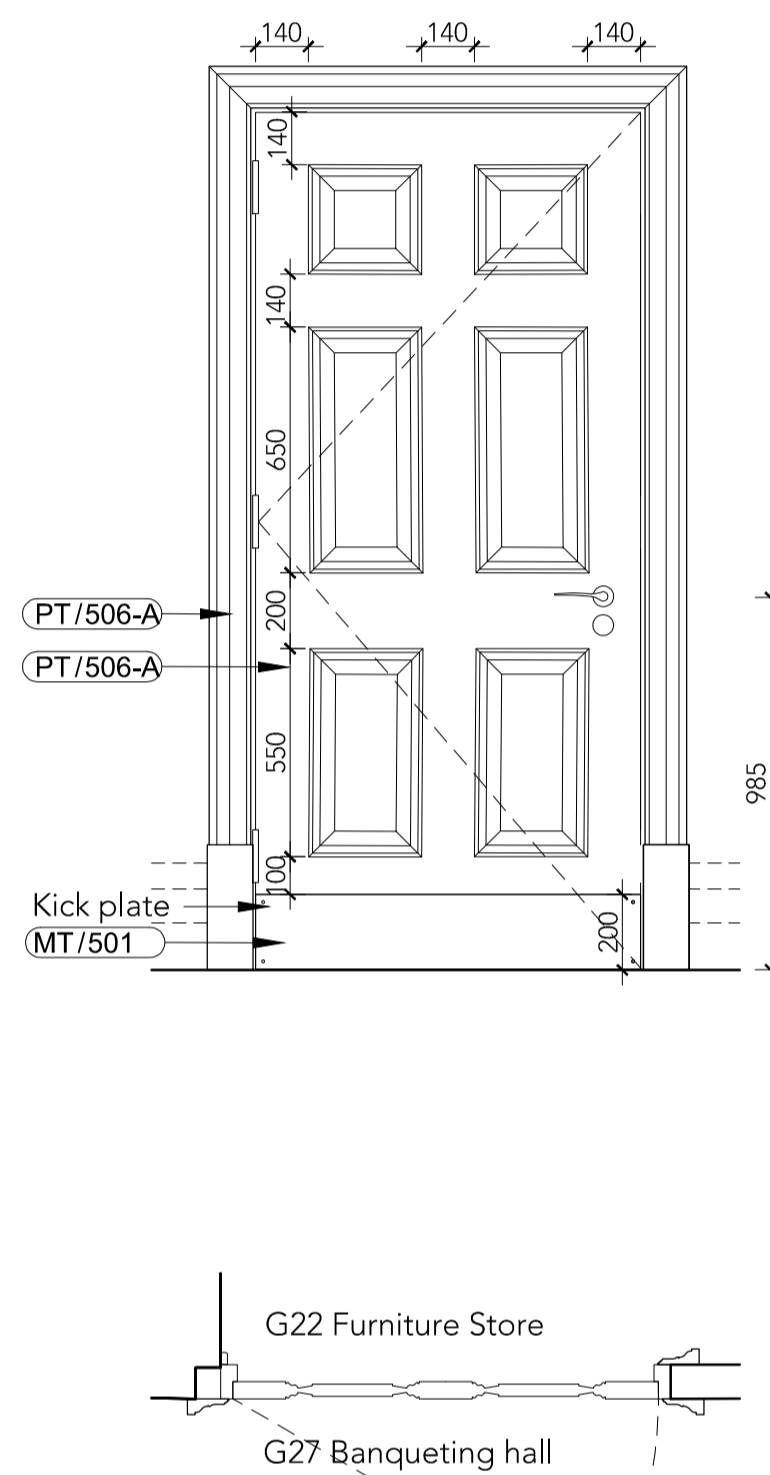
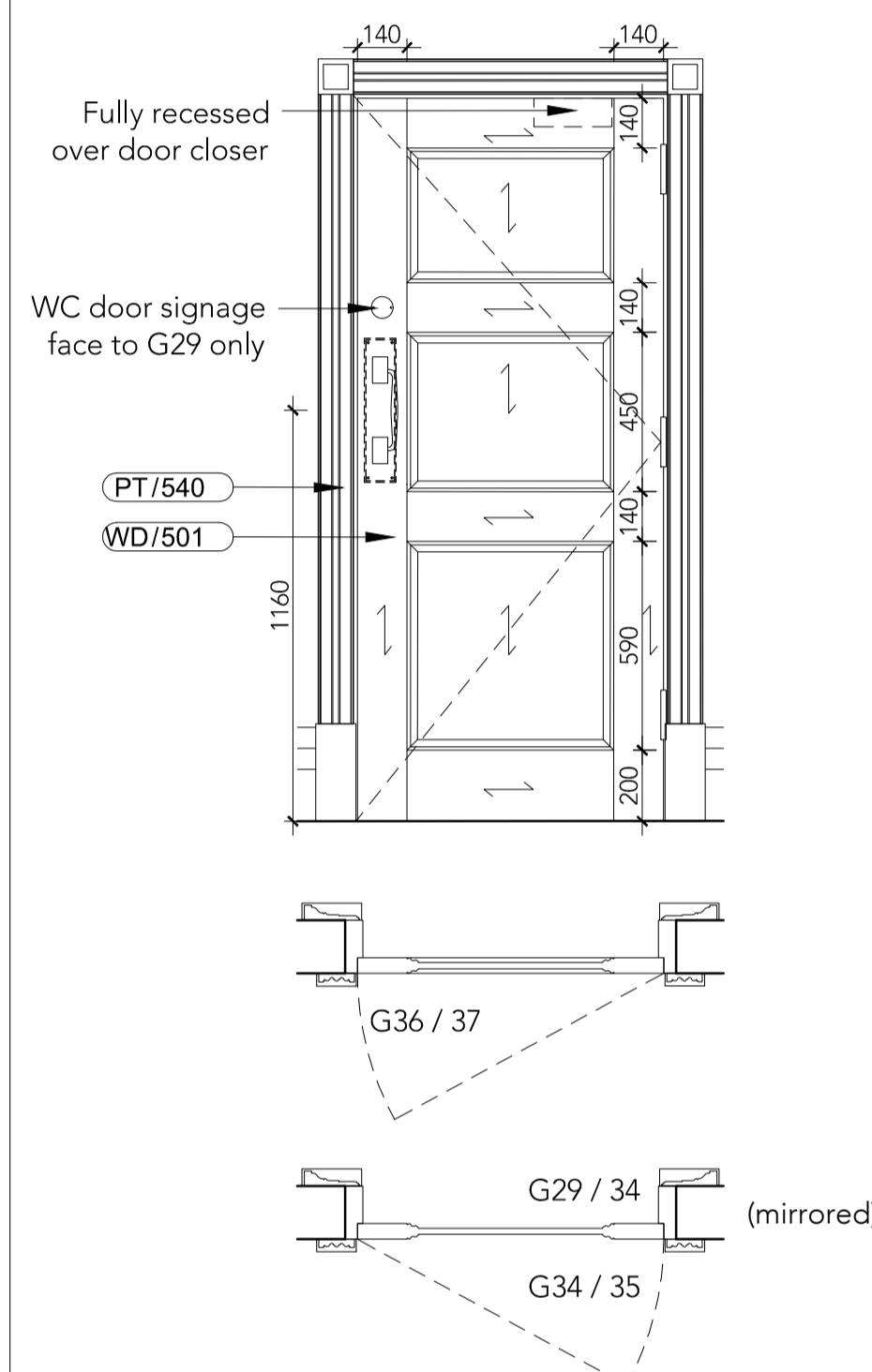
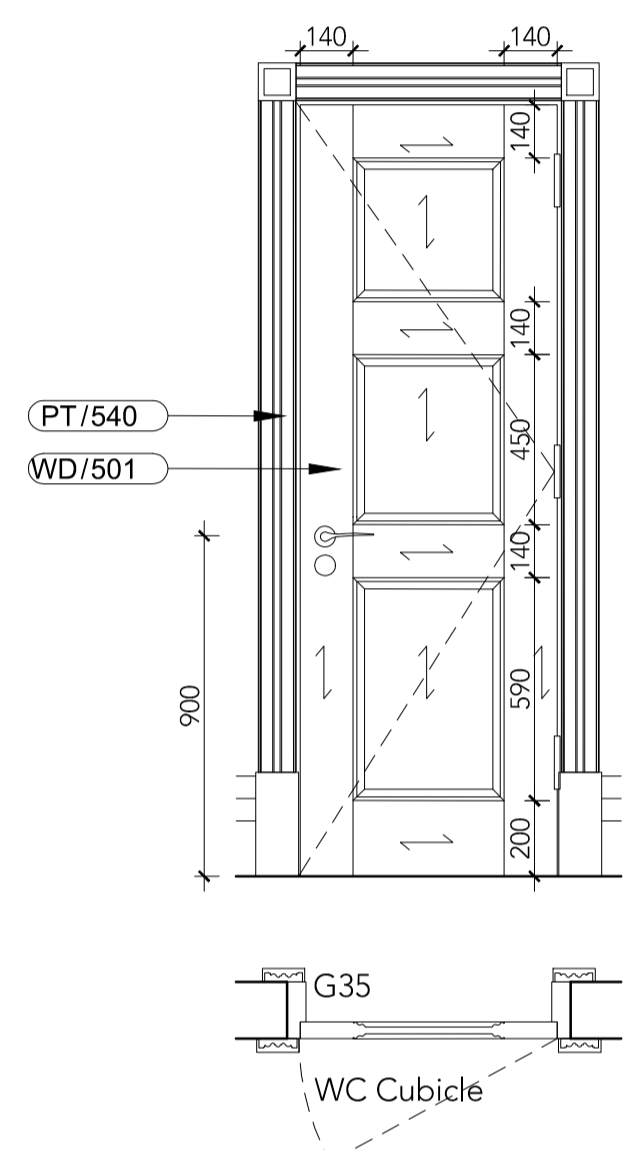

DOOR LEAF TYPE	DL 515
EPR DOOR NO	DG35-02 DG35-03
ARCHITRAVE	AR 502 on hinge opening side AR 503 on reverse
IRONMONGERY SET	WC1.2L Refer to HAF Architectural Hardware Schedule.
NOTES	

DOOR LEAF TYPE	DL 516
EPR DOOR NO	DG36-01 DG37-01 DG34-01 (mirrored) DG35-01 (mirrored)
ARCHITRAVE	AR 502 on hinge opening side AR 503 on reverse
IRONMONGERY SET	PP1 Refer to HAF Architectural Hardware Schedule.
NOTES	

DOOR LEAF TYPE	DL 517
EPR DOOR NO	DG27-03
ARCHITRAVE	To match existing
IRONMONGERY SET	D1.2 Refer to HAF Architectural Hardware Schedule.
NOTES	Keylock

DOOR LEAF TYPE	DL 518
EPR DOOR NO	DG43-01
ARCHITRAVE	To match existing
IRONMONGERY SET	PP2.3 Refer to HAF Architectural Hardware Schedule.
NOTES	

DOOR LEAF TYPE	DL 519
EPR DOOR NO	DG02-01 DG03-01 (mirrored) DG04-01 (mirrored) DG06-01 (mirrored)
ARCHITRAVE	Part of paneling, refer to detail 36, drw PA-5835-DT
IRONMONGERY SET	S2.1 at DG02-01 and DG06-01 S1.1 at DG03-01 and DG04-01 Refer to HAF Architectural Hardware Schedule.
NOTES	

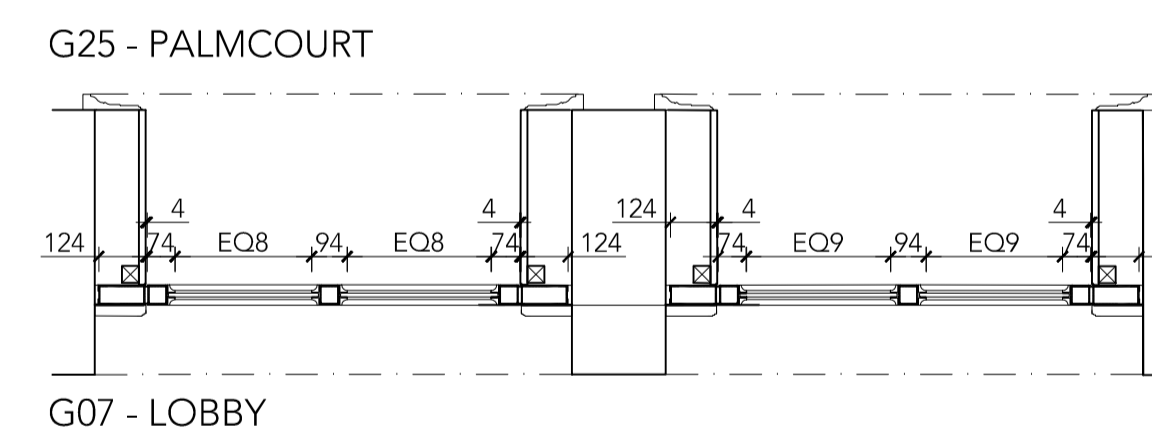
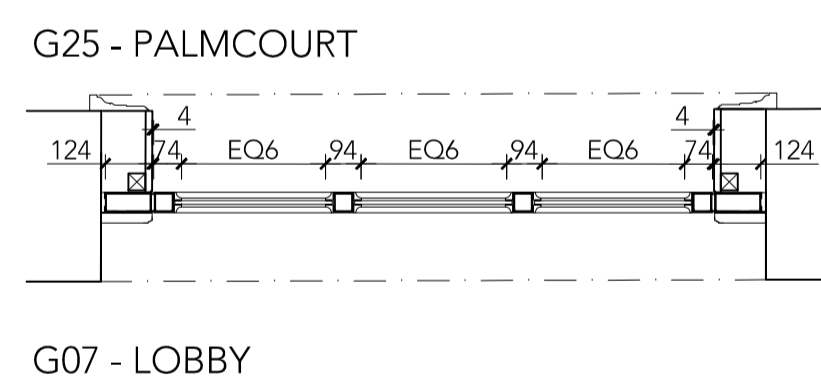
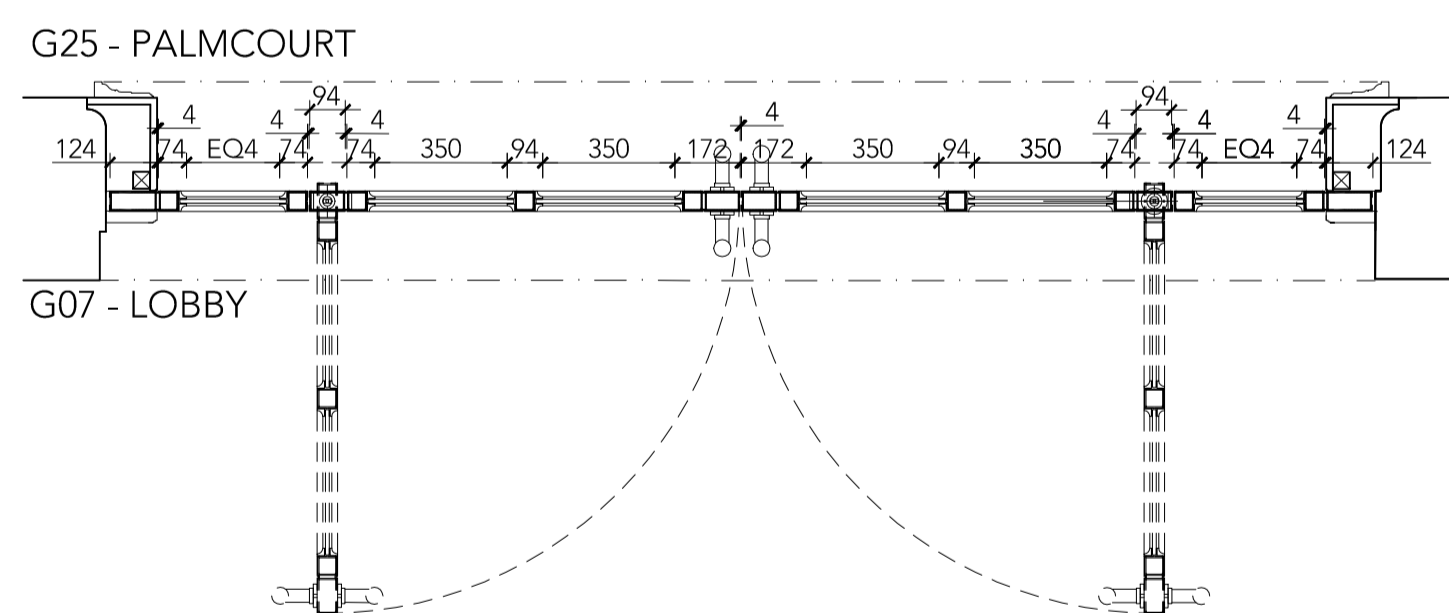
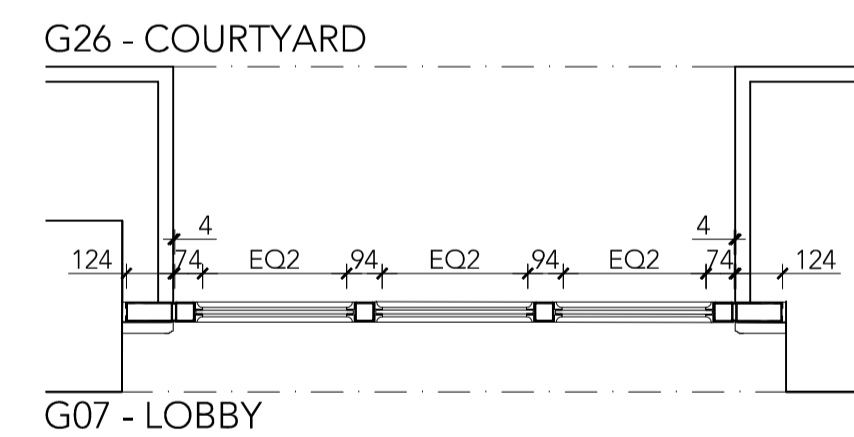
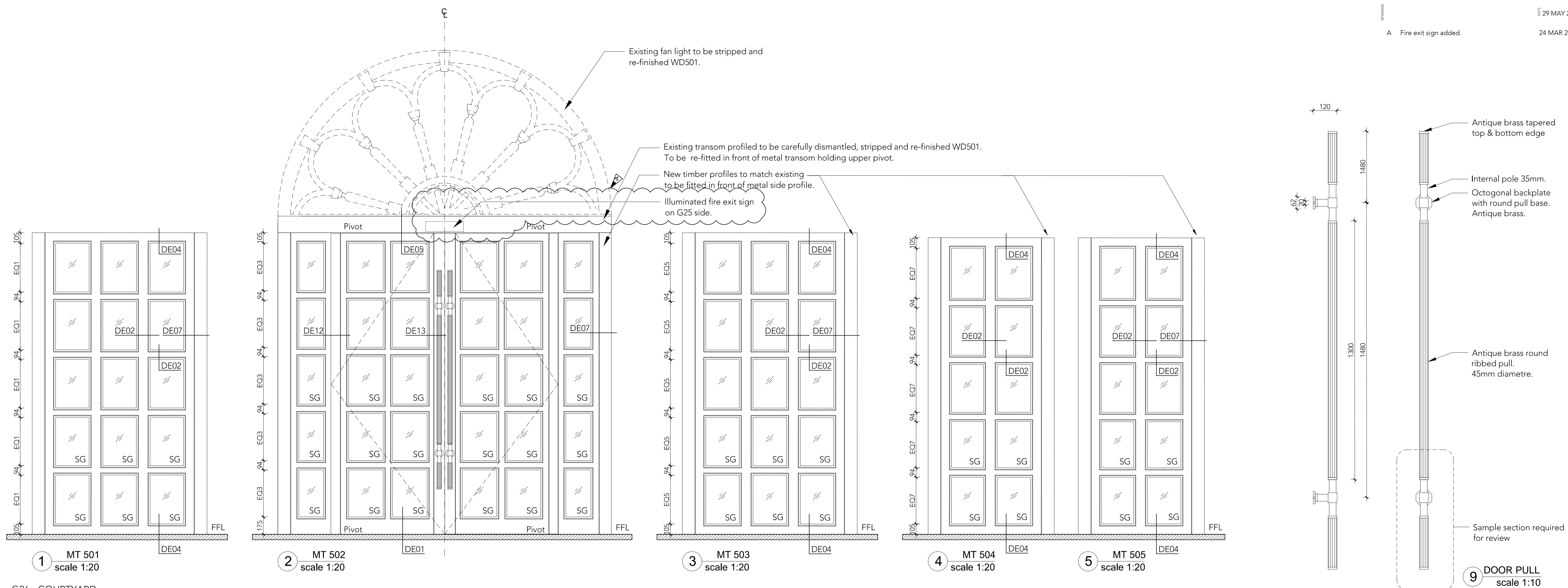

Bespoke pull handle on both sides of both leaves.
Refer to figure 9. Handle to be centered on door height.

2x DS-500 Door Stops
Refer to Ironmongery Schedule PA-5930-SH

Metal framed glass doors and fixed partitions.
Manufacturer - Satin Stainless www.satinstainless.co.uk

Where else not stated metal finish to match MT501,
glass to be clear, SG indicates extent of tempered glass.

Door to have double swing floor pivot without closing
mechanism, ball catch at top of door.

Further development by manufacturer required to provide
shop drawing for Tara Bernerd & Partners to review.

For details refer to drawings PA-5812/5813-JN

Tara Bernerd & Partners

1 HANS STREET LONDON SW1X 0J T +44(0)20 7245 1658 tarabernerd.com

PROJECT RUSSELL HOTEL

PUBLIC AREAS

DRAWING GROUND FLOOR
METAL DOORS AND PARTITIONS
MT 501 - MT 504, HANDLE DETAIL

DATE 29 MAY 2015 DRAWN BY TG CHECKED BY TG

STATUS TENDER 2 SCALE @ 1:20, 1:10

DWG NO. PA-5810-JN REV A

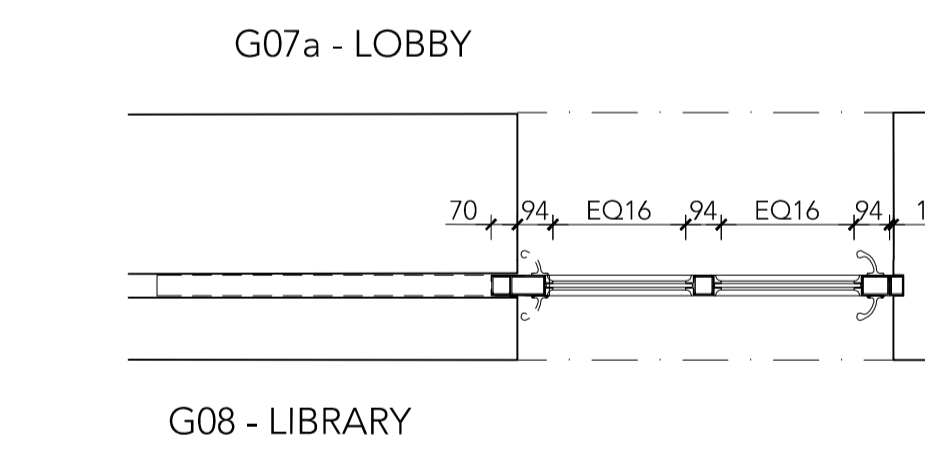
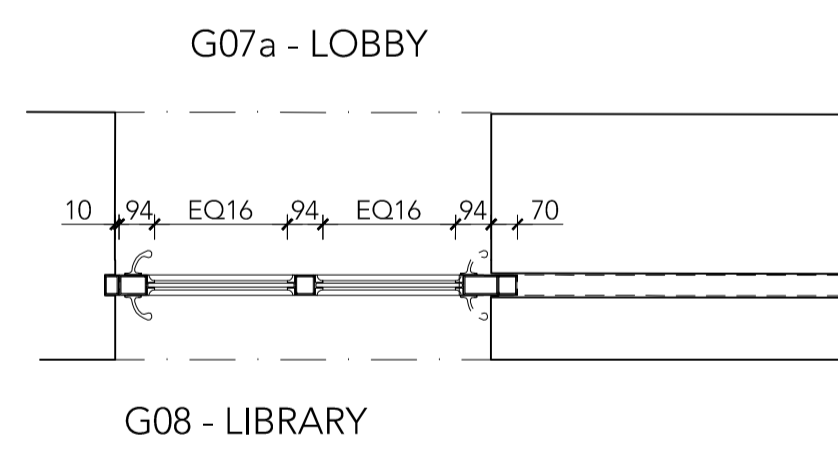
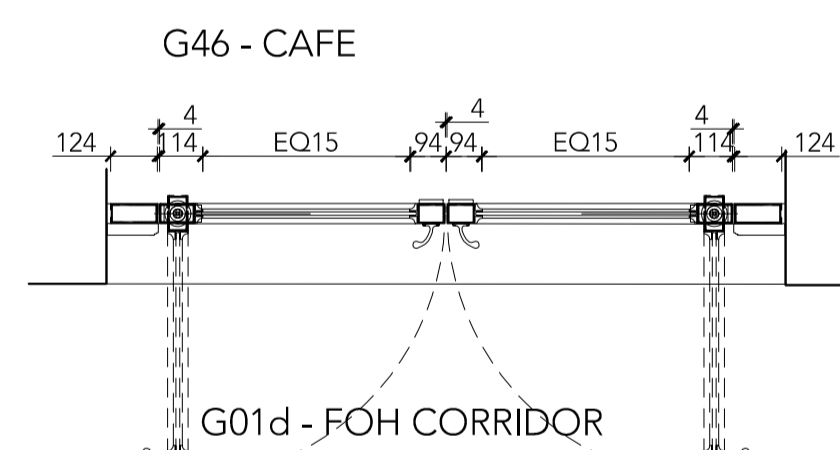
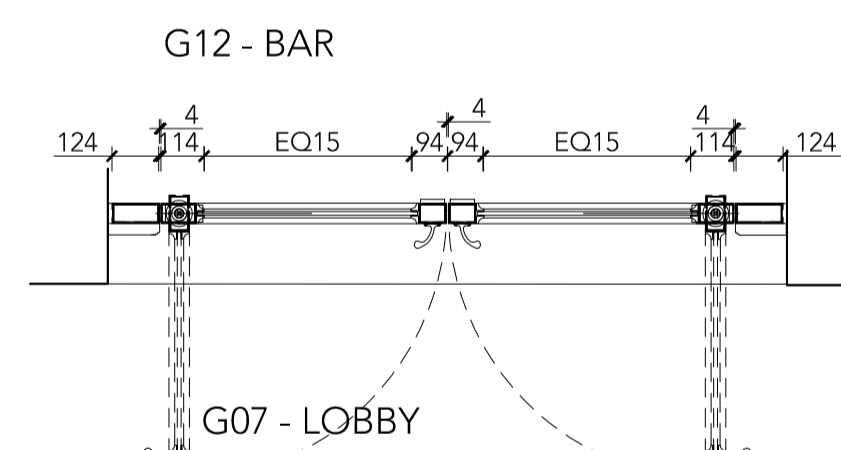
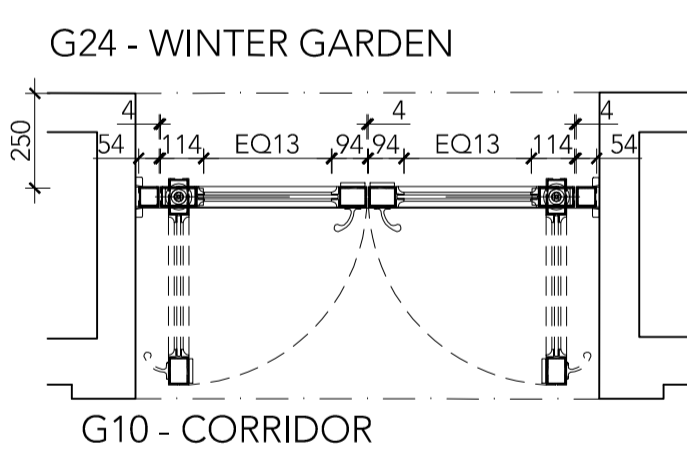
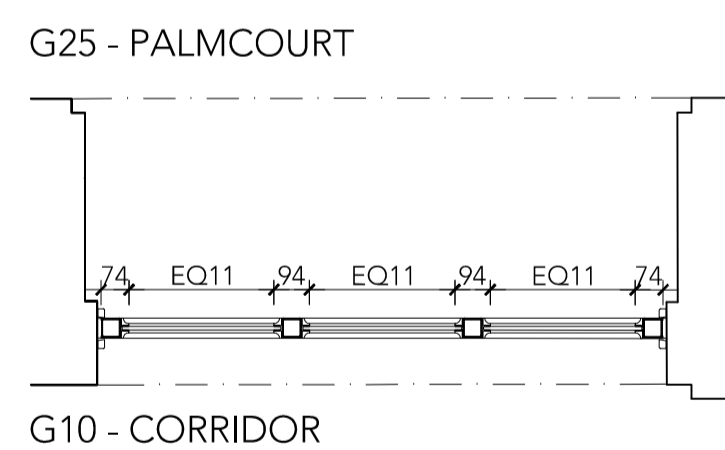
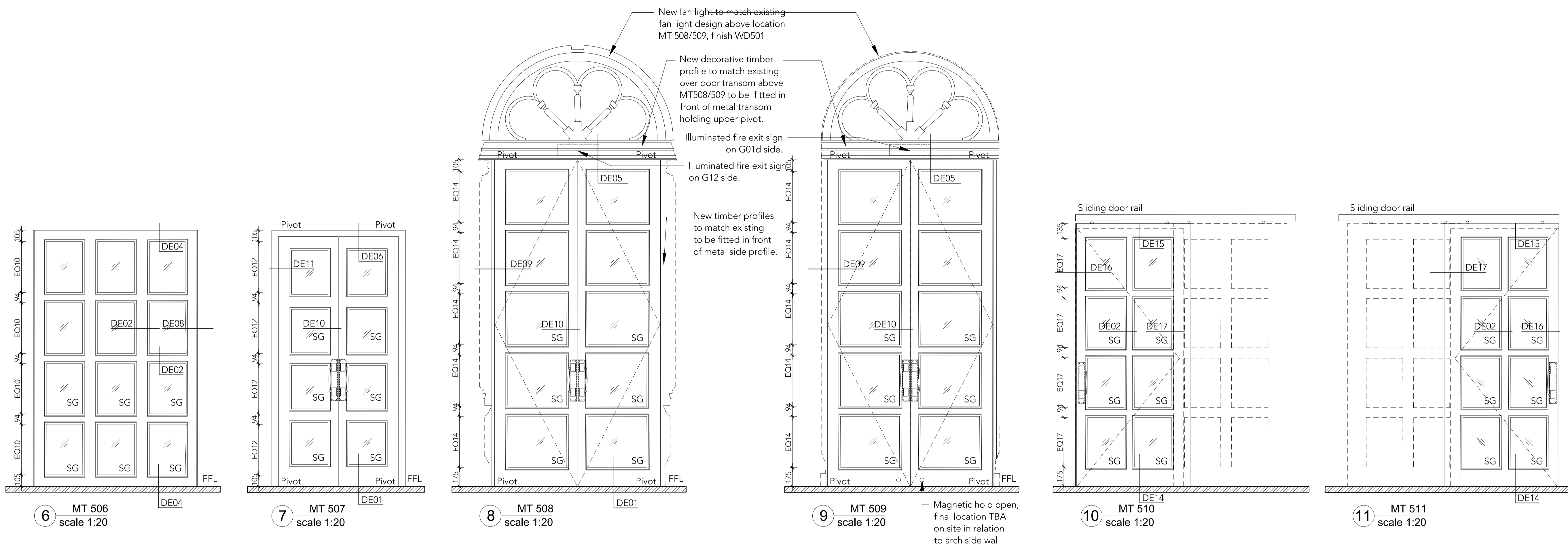

1 pair of PH-500 Pull Handles
on side facing G10 Corridor

1 pair of PH-501 Push Plate
on side facing G24 Winter Garden

2x DS-500 Door Stops
Refer to Ironmongery Schedule PA-5930-SH

1 pair of PH-500 Pull Handles
on side facing G7 Lobby

1 pair of PH-501 Push Plate
on side facing G12 Bar

2x DS-500 Door Stops
Refer to Ironmongery Schedule PA-5930-SH

1 pair of PH-500 Pull Handles
on side facing G7 Lobby

1 pair of PH-501 Push Plate
on side facing G12 Bar

2x DS-500 Door Stops
Refer to Ironmongery Schedule PA-5930-SH

NOTE - Firedoor FD60S / Fire Escape
Locking device to suit device to be requested

1 pair of PH-500 Pull Handles
on either side

Sliding door gear to be fully fitted
with floor guide and buffer stop.

To be fitted with electromagnetic lock device
controlled by card reader CR-500 and request
to exit button RE-500.

Note - Glass to be GL502.

1 pair of PH-500 Pull Handles
on either side

Sliding door gear to be fully fitted
with floor guide and buffer stop.

To be fitted with electromagnetic lock device
controlled by card reader CR-500 and request
to exit button RE-500.

Note - Glass to be GL502.

Tara Bernerd & Partners

1 HANS STREET LONDON SW1X 0J T +44(0)20 7245 1658 tarabernerd.com

PROJECT
RUSSELL HOTEL
PUBLIC AREAS

DRAWING
GROUND FLOOR
METAL DOORS AND PARTITIONS
MT 506 - MT 508

DATE	29 MAY 2015	DRAWN BY	TG	CHECKED BY	TG
STATUS	TENDER 2	SCALE @ A1	1:20		
DWG NO	PA-5811-JN	REV	A		