

Please note that information used to produce these drawings is based on measured survey supplied by others. Heritage Architecture can not be held responsible for any inaccuracies that may exist. Please do not scale drawings. All dimensions should be verified on site.

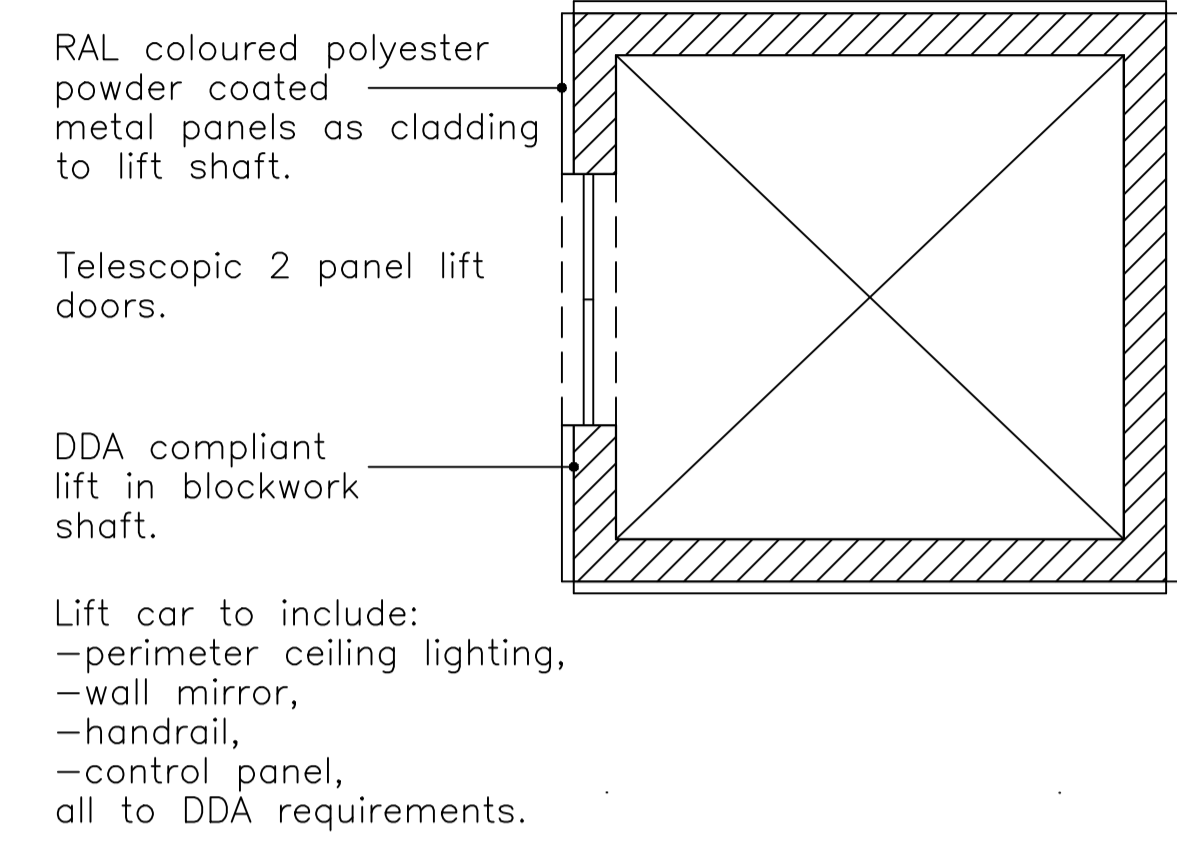
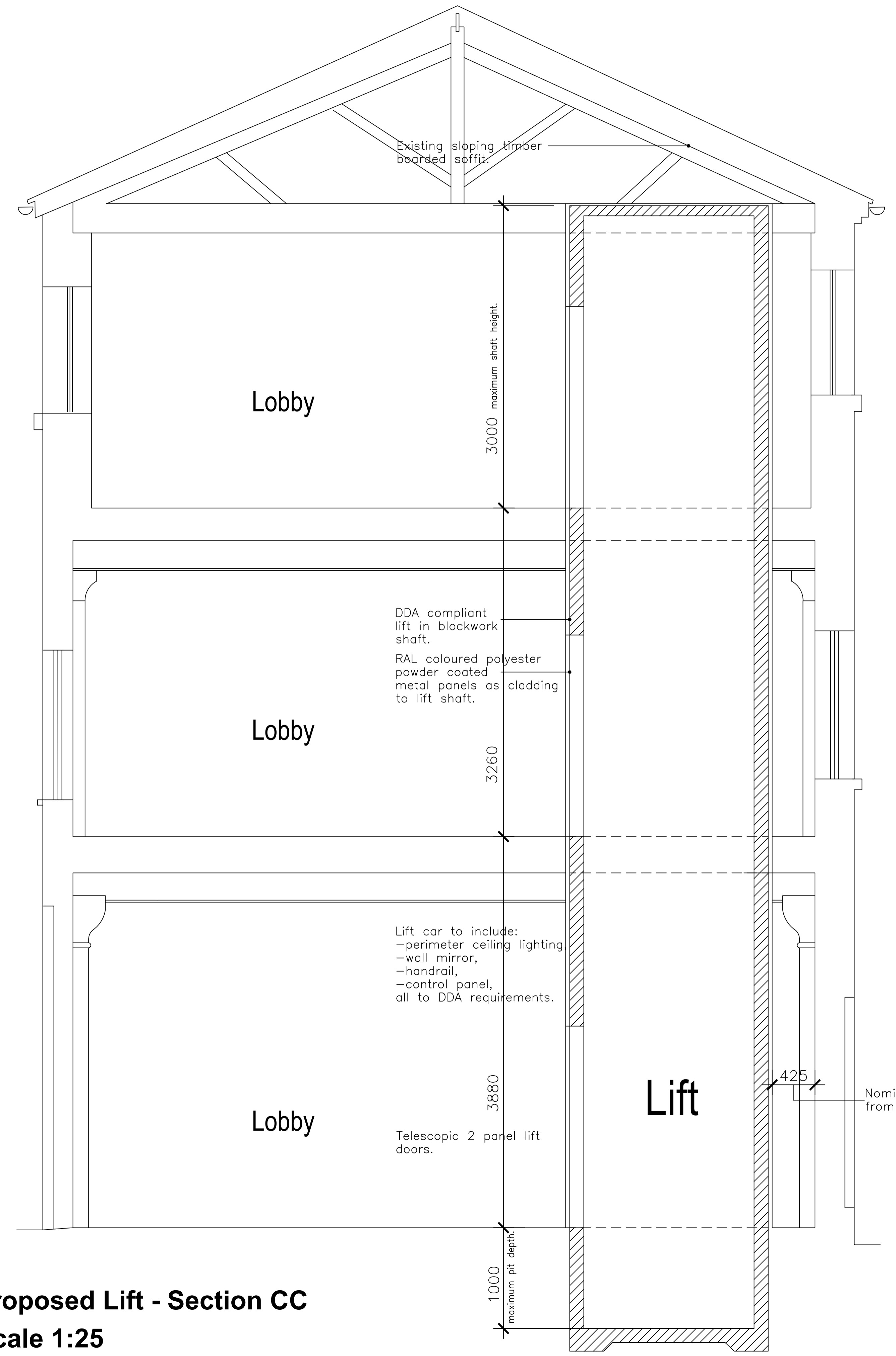

**Proposed Lift - Typical plan**  
**Scale 1:25**

**Proposed Lift - Section CC**  
**Scale 1:25**

Camden Stables Market  
London  
NW1  
United Kingdom

STANLEY SIDINGS LTD

**Camden Stables Market**  
**PROVENDER STORE (BLOCK B)**

Drawing Title  
**New stairs, lifts & associated builders work - Proposed lift - Plans & Section CC**

Scale 1:25 @ A1

Drawing Status  
Planning & Listed Building Consent

July 2016 Drawing No B-06



**STEPHEN LEVRANT HERITAGE ARCHITECTURE**  
62 British Grove, London, W4 2NL  
E-mail: info@heritagegmail.co.uk