

Thorp Arch, Wetherby,
West Yorkshire, England, LS23 7FS
Phone 01937 541118
Email geotechnique@keller.co.uk

Unit 5, Weyside Park
Newman Lane, Alton, GU34 2PJ
Phone 01420 590328
Email geotechnique@keller.co.uk

Ground Floor, 108 Mere Grange
Leaside Road, St Helens, WA9 5GG
Phone 01744 818009
Email geotechnique@keller.co.uk

Tower Business Park,
Derby Road, Clay Cross
Phone 01246 860988
Email geotechnique@keller.co.uk

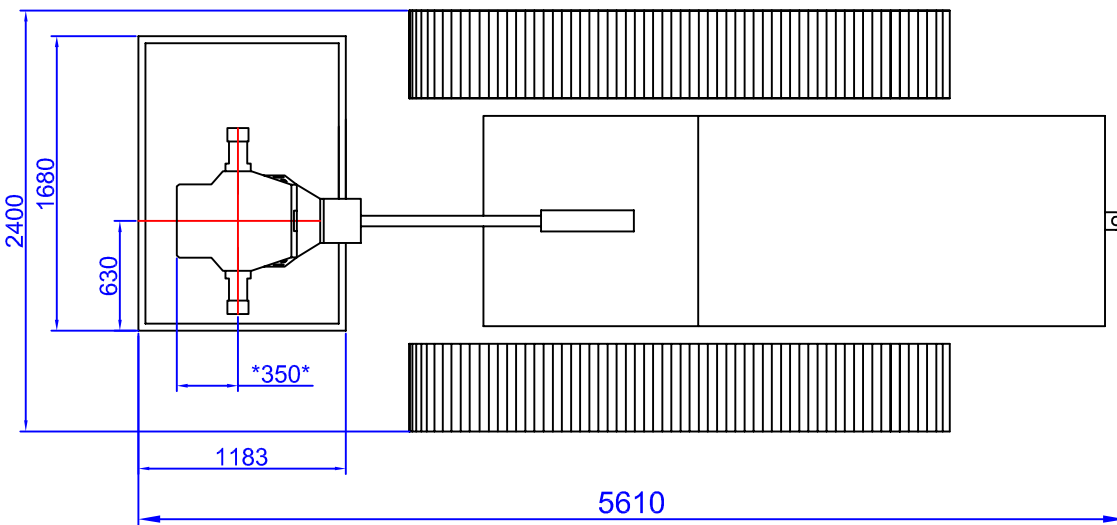
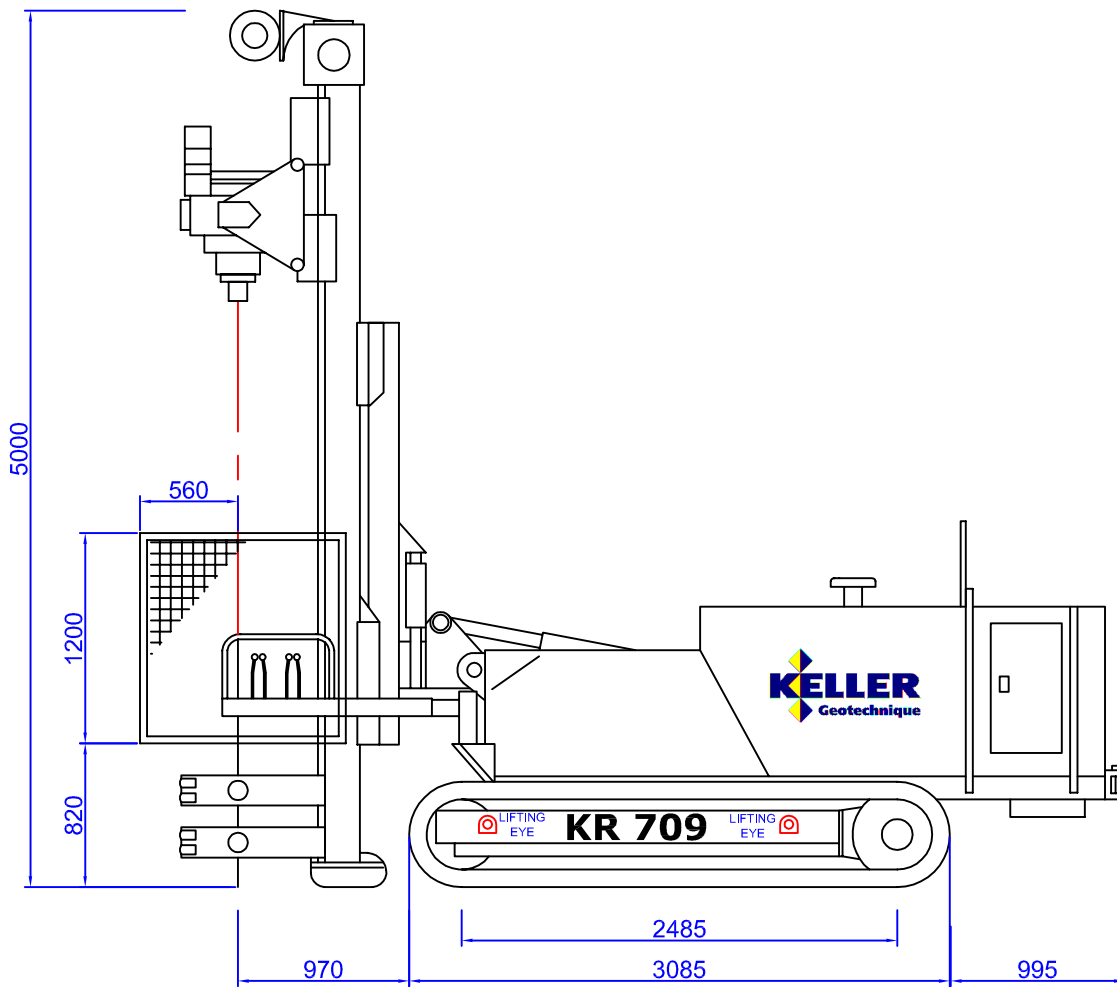

* DIMENSION* = 430mm IF USING 660mm CASING

Rig Data

Rig Weight	13500Kg
Maximum Pile Diameter	508/660mm
Maximum Pile Length	30m
Drilling Techniques	Rotary Case & Auger Flight Auger DTH Hammer Diesel
Power	
Power Pack Dimensions (mm)	-
Power Pack weight	-
Noise Levels	TBC Leq at 5m
Rig Transport Dimensions (mm)	5140L 3155H 2400W
Mast Articulation	
Forward	5°
Back	90°
Side	±15°

Notes
All KG Drilling rigs are equipped with fully interlocked guards in accordance with the PUWER regulations

FPS Platform design
Working Platform Certificate required to operate all KG Drilling Rigs

TITLE KLEMM KR 709				
SCALE	ORIG. SIZE	DRAWN	CHECKED	AUTHORISED
N/A	A4	J.D.T.		
DRAWING NUMBER				REV
				-