

WINDOW 1
UC3

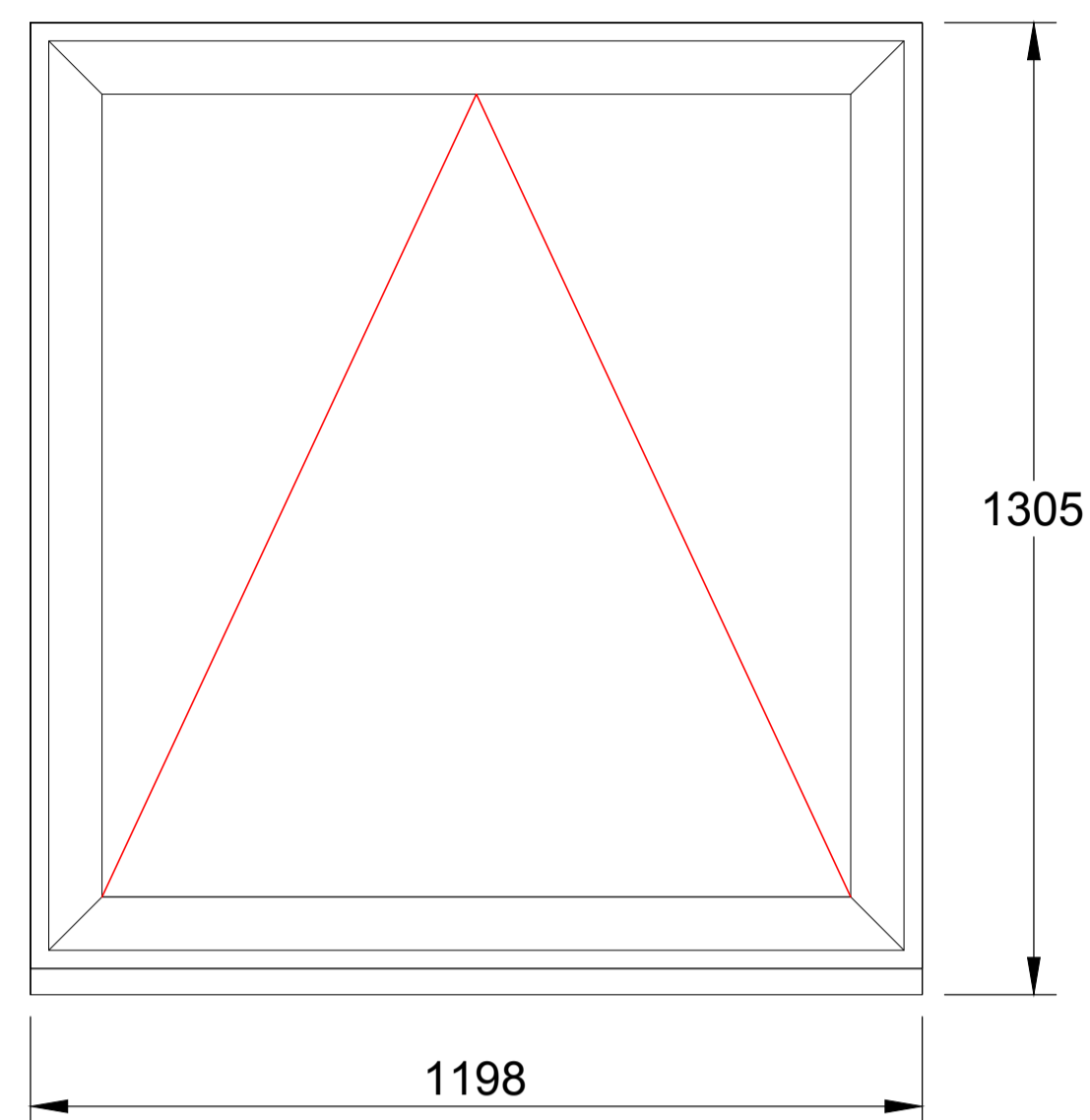

WINDOW 2
UC28

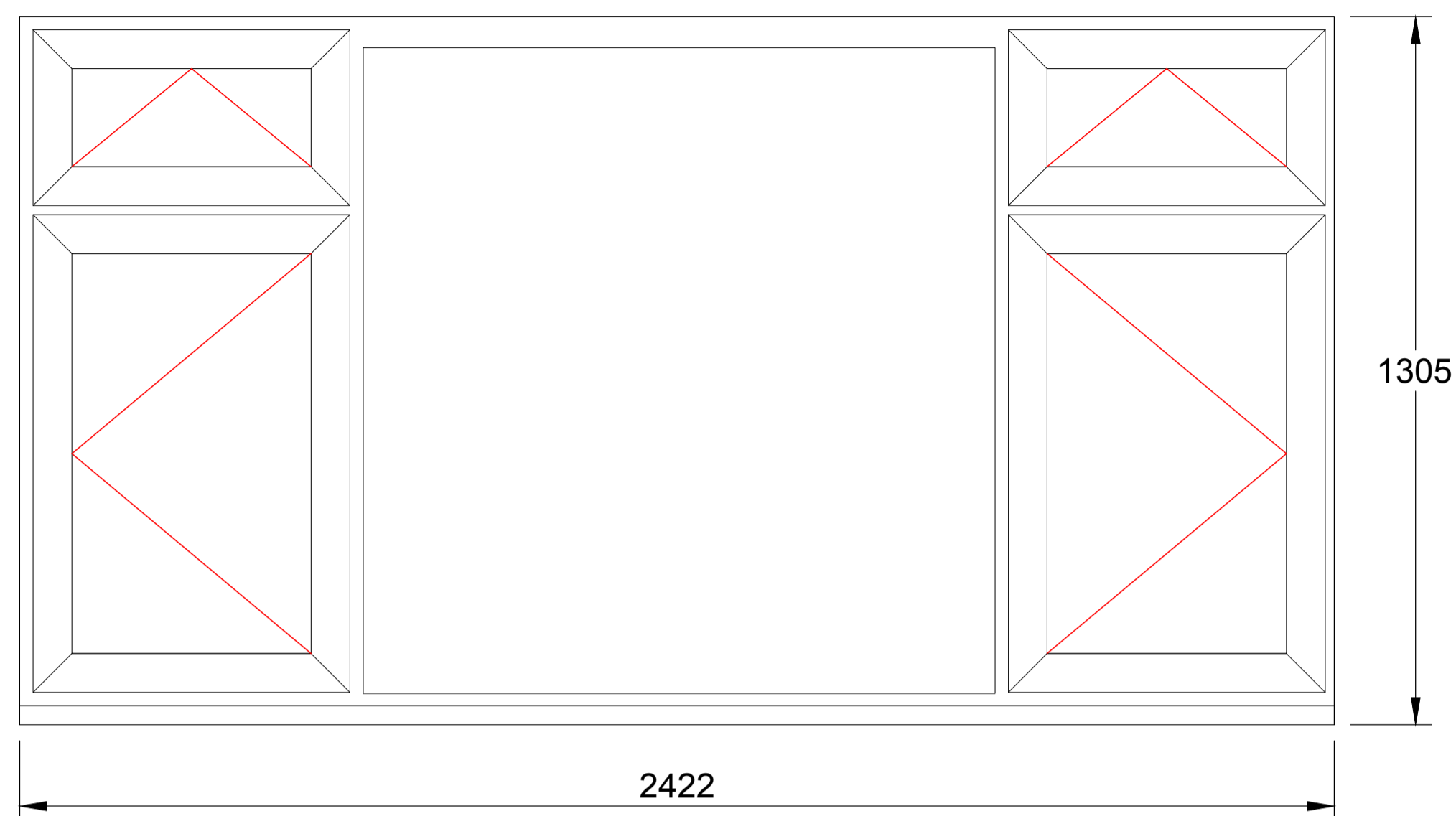

WINDOW 4
UC64

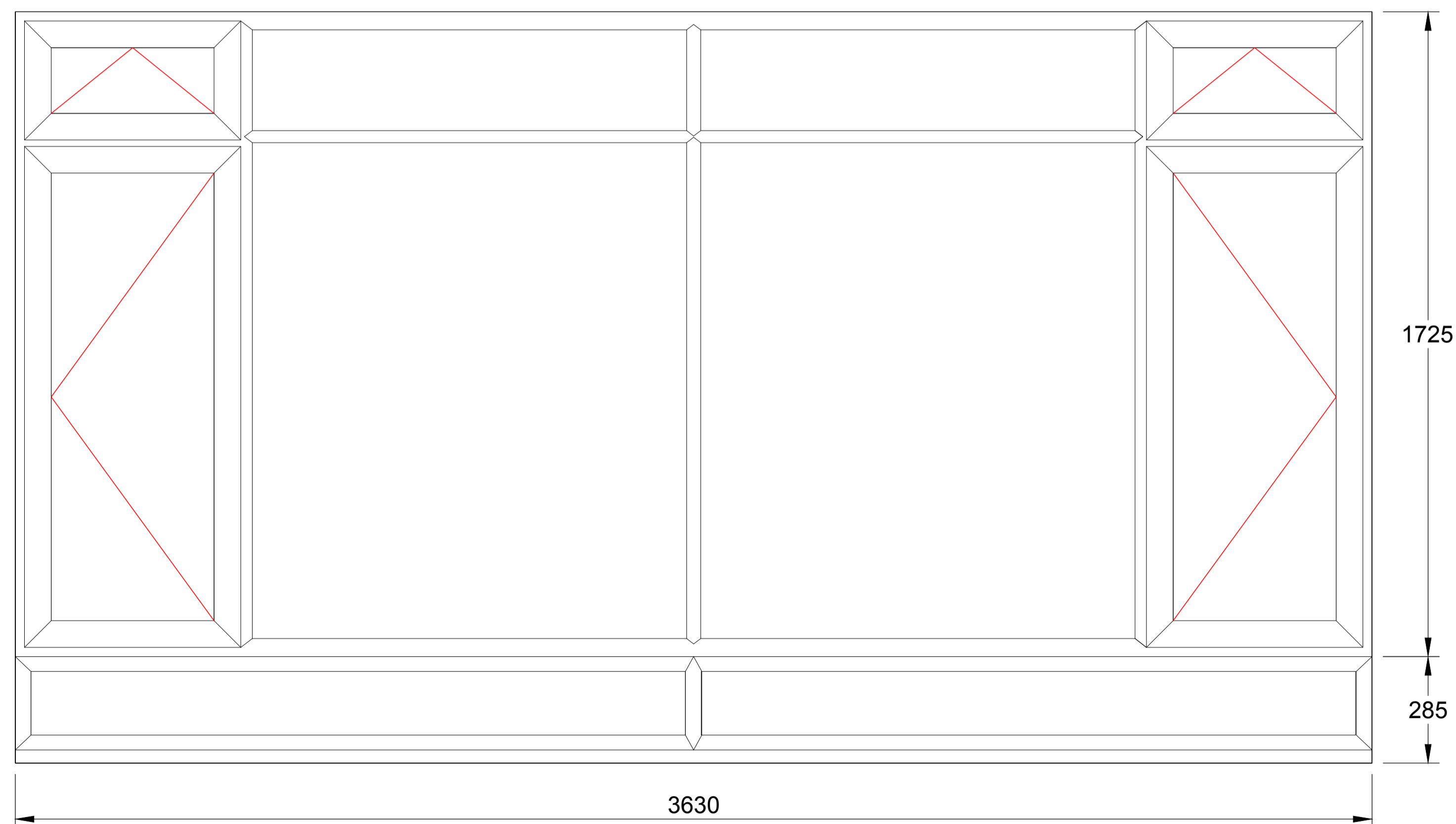

WINDOW 3
UC5

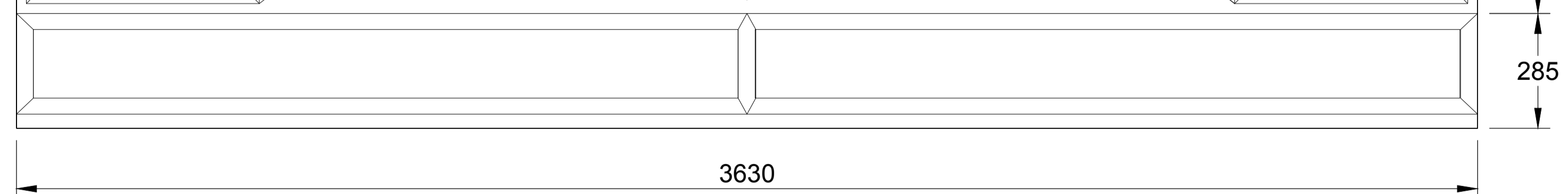

- 1) RearBedL Window-Essentials uPVC Casement Windows UC3, 1198 mm. wide x 1305 mm. high, Arched Head infill: White, Finish: White, Glass Whole Frame: 4mm Clear, Handle Finish: Chrome, Handle Style: Modern, Restrictor Type: Non-Locking, Sash Finish: White, Sealed Unit Type: Essentials Sealed Unit, Spacer Colour: Grey, Style: Standard, Window Boards: White
- 2) RearBedR Window-Essentials uPVC Casement Windows UC28, 2422 mm. wide x 1305 mm. high, 1st Transom: 334, Arched Head infill: White, B Dimension: 605, C Dimension: 1817, Finish: White, Glass Whole Frame: 4mm Clear, Handle Finish: Chrome, Handle Style: Modern, Handle Type(Fire Escape): Locking, Restrictor Type: Non-Locking, Sash Finish: White, Sealed Unit Type: Essentials Sealed Unit, Spacer Colour: Grey, Stay Type: Egress(Fire), Style: Standard, Window Boards: White
- 3) FrontBed Window 1-Essentials uPVC Casement Windows UC5, 3630 mm. wide x 285 mm. high, B Dimension: 1815, Cheek Type: 2:Sides and Head, Finish: White, Glass Whole Frame: Contora, Sealed Unit Type: Essentials Sealed Unit, Spacer Colour: Grey, Style: Standard
- 4) FrontBed Window 2-Essentials uPVC Casement Windows UC64, 3630 mm. wide x 1725 mm. high, 1st Transom: 334, B Dimension: 605, C Dimension: 1815, Cheek Type: 2:Sides and Head, D Dimension: 3025, Finish: White, Glass Whole Frame: 4mm Clear, Handle Finish: Chrome, Handle Style: Modern, Handle Type(Fire Escape): Locking, Restrictor Type: Non-Locking, Sash Finish: White, Sealed Unit Type: Essentials Sealed Unit, Spacer Colour: Grey, Stay Type: Egress(Fire), Style: Standard, Window Boards: White

1. All dimensions in millimetres (mm) and levels in metres (m) unless noted otherwise.
2. This drawing to be read in conjunction with all other relevant drawings and specification.
3. All work to comply with the relevant British Standards, Codes of Practice and the Building Regulations.

Revisions:

Customer: Mr Amit Ranna
Flat 6
24 Buckland Crescent
London
NW3 5DU

Drawing Title:
Details

Drawing No: **3307/PP/04** Revision:

Scale: **1:10** Date: **05 July 2016**

Drawn: **I.MURCIA** Size: **A1** Contract No: **SO3307AU**

© Crown copyright. All rights reserved.
License numbers 010031673 and 100042205

