

6 ELEVATION A
Scale: 1:8

7 PLAN
Scale: 1:8

8 CUT PLAN B
Scale: 1:8

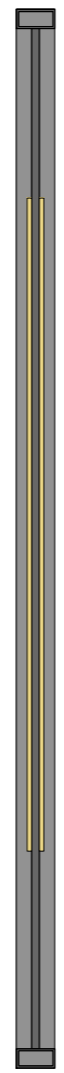

9 SECTION A
Scale: 1:5

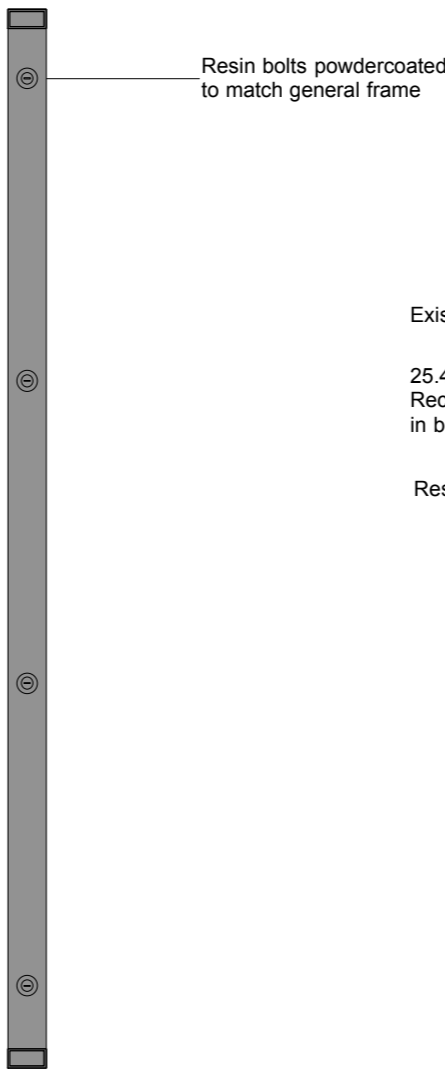

10 SECTION B
Scale: 1:5

Joiner to suggest appropriate fixing to shopfront

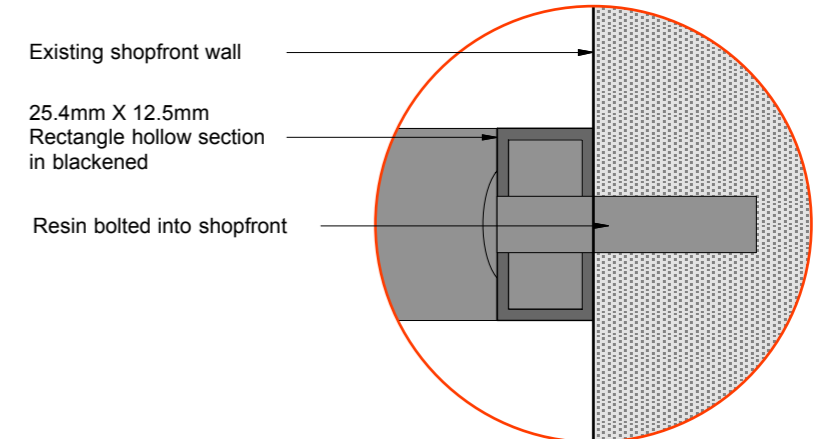

11 DETAIL B
Scale: Actual Size

DETAIL A

DETAIL B

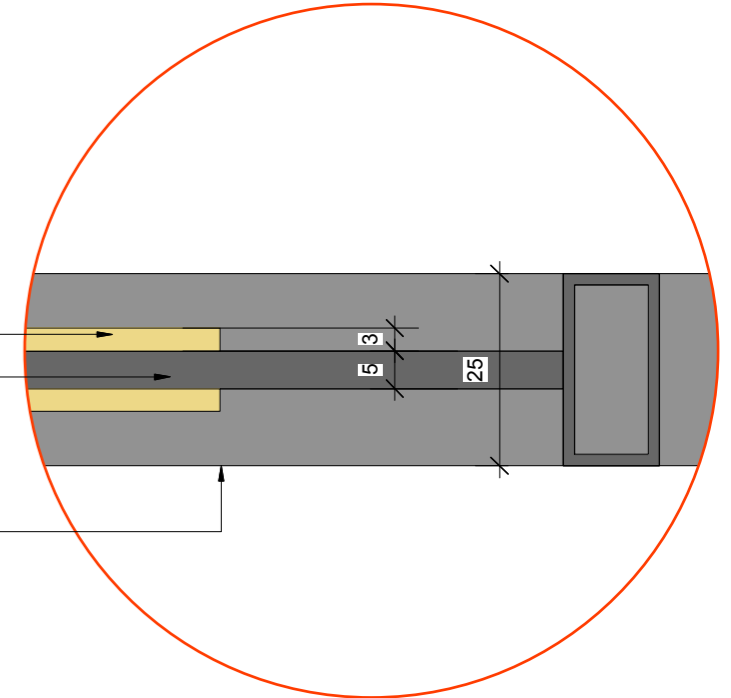

12 DETAIL B
Scale: Actual Size

GENERAL NOTES

- ALL ASPECTS OF THIS DRAWING ARE SUBJECT TO SITE SURVEY AND PREPARATION OF FULL SETTING OUT DRAWINGS BY MAIN CONTRACTOR. ANY MAJOR DISCREPANCIES TO BE DISCUSSED WITH BW PRIOR TO MANUFACTURE OF COMPONENTS. ALL AREAS WHERE HEIGHTS ARE CRITICAL ARE TO BE SURVEYED AND SETTING OUT DRAWINGS PREPARED AT THE EARLIEST OPPORTUNITY.
- ALL DIMENSIONS RELATING TO SUPPLIERS OR SUB-CONTRACTORS MUST BE CHECKED AND AGREED BETWEEN THE MAIN CONTRACTORS AND SUPPLIERS OR SUB-CONTRACTORS.
- THIS DRAWING REPRESENTS DESIGN INTENT ONLY. SPECIALIST SUB-CONTRACTORS ARE RESPONSIBLE FOR THE ACCURATE, SAFE AND 'FIT FOR PURPOSE' EXECUTION OF ALL ISSUES UNDER THEIR DOMAIN. OVERALL RESPONSIBILITY FOR IMPLEMENTATION LIES WITH THE MAIN CONTRACTOR. ALL VARIATIONS WHICH MAY BE THE RESULT OF TECHNICAL SAFETY REQUIREMENTS MUST BE DISCUSSED WITH BW PRIOR TO IMPLEMENTATION. WHERE VARIATIONS ARE NECESSARY, PROFILE OF ORIGINAL DESIGN INTENT MUST BE MAINTAINED OR ALTERNATIVE PROPOSALS SUBMITTED TO BENEDICT WILHELM FOR CONSIDERATION.
- CONTRACTOR TO ENSURE ALL DETAILS ARE COMMENSURATE WITH STRUCTURAL STABILITY.
- ALL DETAILS ARE TO CONFORM WITH RELEVANT STATUTORY REQUIREMENTS.
- ALL ELECTRICAL INSTALLATION TO COMPLY WITH CURRENT INDUSTRY REGULATIONS AND GOOD PRACTICES.
- ALL DESIGN PROFILES TO BE MAINTAINED IN DETAILING AND MANUFACTURING.
- FOR INFORMATION ON GRAPHICS/SIGNAGE REFER TO SEPARATE GRAPHICS PACKAGE.
- DRAWINGS TO BE READ IN CONJUNCTION WITH STANDARD SITE DRAWING PACKAGE.
- IF IN DOUBT, ASK, CONSULT OR ADVISE PLEASE DO NOT ASSUME.

NOTES:
New signage design

REVISIONS:	
A	02.03.2016

<p>BENEDICT WILHELM</p>	CLIENT	Manifesto	
	PROJECT / ADDRESS	0171 / 96 Leather Lane	
	DRAWING	Sign Details	
	DRAWING NO.	0171_205	
	DATE	29.01.2015	REV
SCALE	- @ A3	CHECKED BY	-
DRAWN BY	SF		

This drawing is the property of Benedict Wilhelm Limited and they reserve the copyright. The drawing is issued on the condition that it is not copied, reproduced, related or disclosed, in whole or in part, to any unauthorised person without consent in writing from Benedict Wilhelm Limited. Figured dimensions are to be taken in preference to those scaled. The contractor is to verify all dimensions and conditions on site.

ALL ELEMENTS OF THIS DRAWING ARE TO BE SET OUT BY CONTRACTOR AND TO BE APPROVED BY BW PRIOR TO ANY IMPLEMENTATION