

EXISTING SOUTH ELEVATION

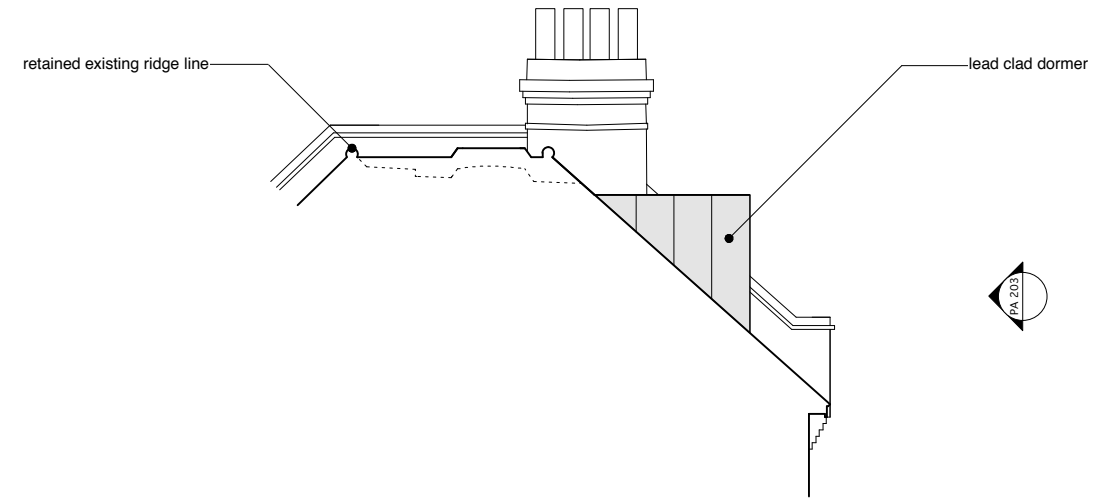

PROPOSED SOUTH ELEVATION

Notes

These plans and specifications prepared by Robert Dye Architects LLP as instruments of professional service shall remain the property of Robert Dye Architects LLP.

These plans may not be copied or re-used without the express written consent of Robert Dye Architects LLP. The use of these plans for construction is permitted only when specifically released for construction reference by a dated authorised signature.

These plans are project and site specific and shall only be used for their intended purpose unless otherwise permitted by written consent of Robert Dye Architects LLP.

All dimensions shown are indicative and must be double checked on site by the contractor. Any inconsistencies found must be reported to Robert Dye Architects LLP.

DO NOT SCALE FROM THE DRAWING

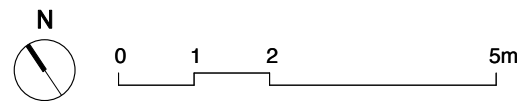

Rev	Date	Notes	robertdye	
A	08.06.16	Dormer lowered as per Planning Officer request	Robert Dye Architects LLP 4 Ella Mews, Cressy Road London NW3 2NH	
			tel: 020 7267 9388 fax: 020 7267 9345	
			www.robertdye.com email: info@robertdye.com	
			project	project no
			15 Platts Lane	255
			drawing	scale
			Proposed Dormer South Elevation	1:100@A3
				drawn by
				ES
			drawing no	date
			PA 204	March 2016
			rev	dwg status
			A	Planning