

PROPOSED U-VALUE TO ACHIEVE	
Ground Floor	0.11 W/m2.K
External Wall - Brickwork with Mastic	0.10 W/m2.K
External Wall - Brickwork with Blockwork: Bin storage, cycle storage, plant room, meter cupboard, caretaker's cupboard.	0.12 W/m2.K
Separating Walls: Flat / Communal Areas	TBC
Separating Walls: Flat / Lift Shaft	TBC
Separating Walls: Flat / Flat Party Walls	0.0*
Roof	0.11 W/m2.K
External Opaque Doors	1.0 W/m2.K
External Windows	1.5 W/m2.K (g-value of 0.63)
External Glazed Doors	1.5 W/m2.K (g-value of 0.63)
AIR PERMEABILITY	4m3/m2.h
* Cavities to be fully filled with mineral wool	

ALL JUNCTIONS BETWEEN INTERNAL CEILING & INTERNAL WALLS AND PENETRATIONS IN AIR BARRIER TO BE SEALED WITH FLEXIBLE SEALANT.

ALL PLASTERBOARD JOINT LOCATIONS TO BE TAPED AND JOINT FINISH.

ALL PLASTERBOARD ON DABS TO HAVE CONTINUOUS RIBBON OF ADHESIVE AROUND ALL OPENINGS, ALONG TOP AND BOTTOM OF WALL, AND AT INTERNAL AND EXTERNAL CORNERS.

DETAILS TO BE READ IN CONJUNCTION WITH SECTIONS & GA PLANS - REFER TO SUITABLE PLASTERBOARD TYPE.

**NOTE**  
Wall tie setouts shown indicatively. Set outs and distances between ties to be installed as per manufacturer instructions

All dimensions to be verified on site by Main Contractor before the start of any shop drawings or work whatsoever either on their own behalf or that of sub-contractors.

Report any discrepancies to the Contract Administrator at once.

This drawing is to be read with all relevant Architect's and Engineer's drawings and other relevant information.

© Ingleton Wood LLP

LEGEND: **DO NOT SCALE**

**GENERAL NOTES**  
This drawing should be read in conjunction with all relevant consultants drawings and specifications.

Setting out dimensions and sizing of all RC elements should be taken from structural engineer's drawings and documentation.

**EXTERNAL & INTERNAL WALL SYMBOLS**

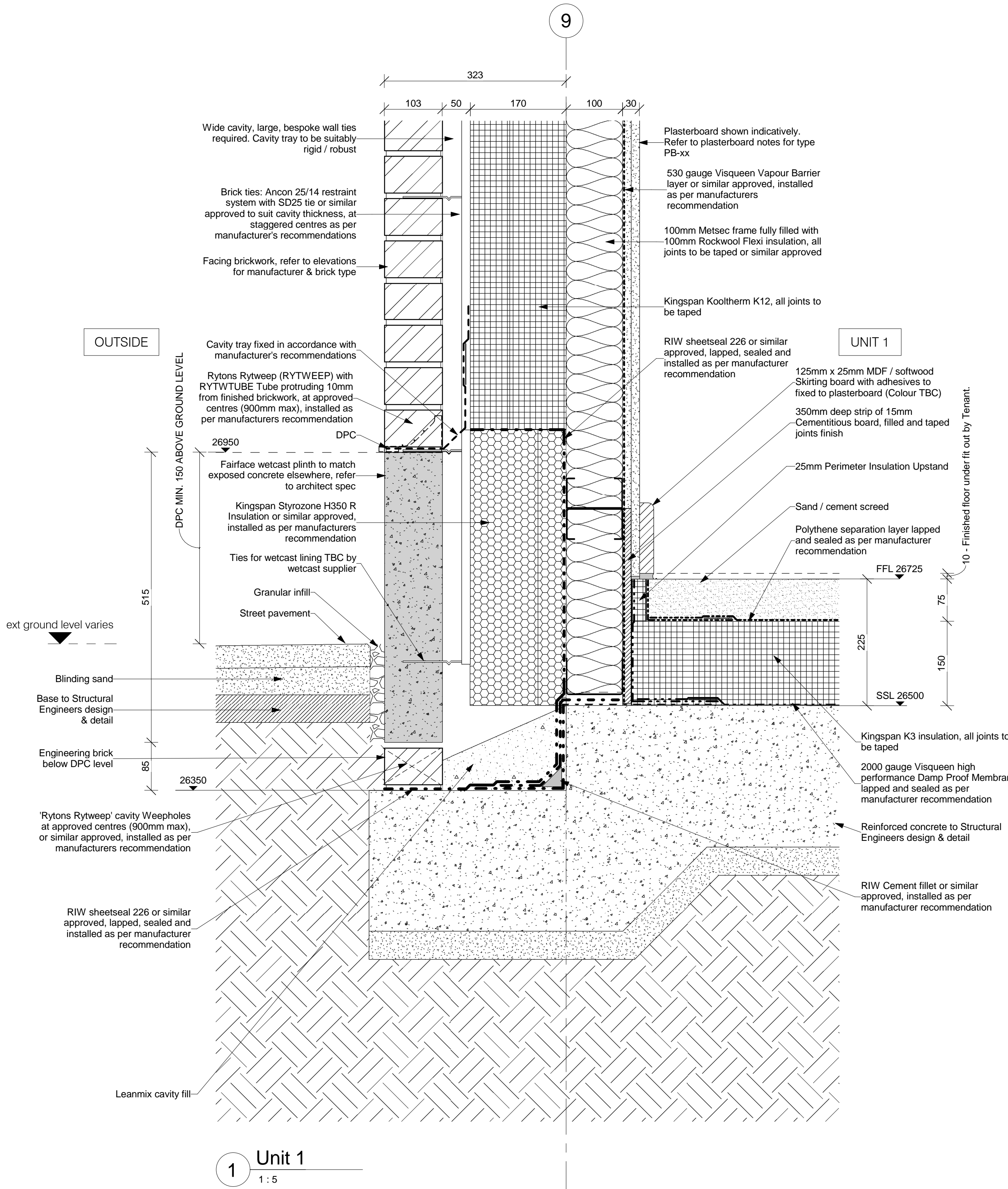
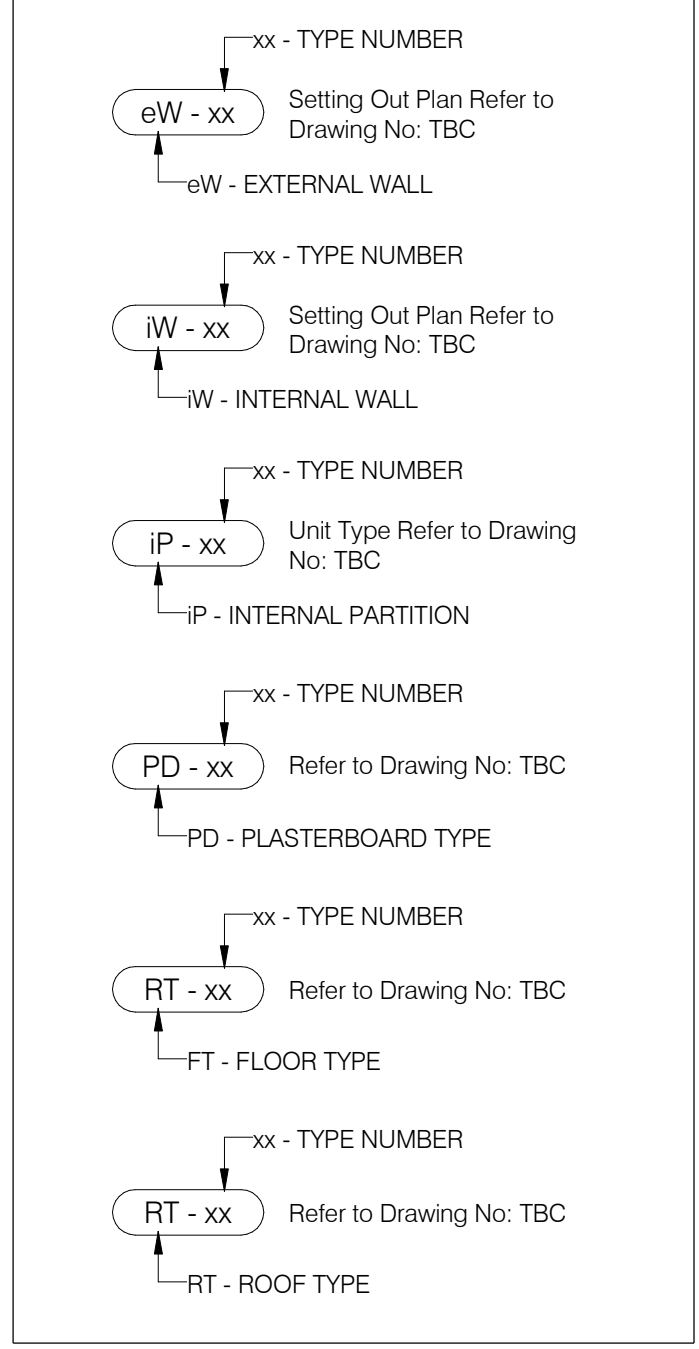

**1** Unit 1  
1:5

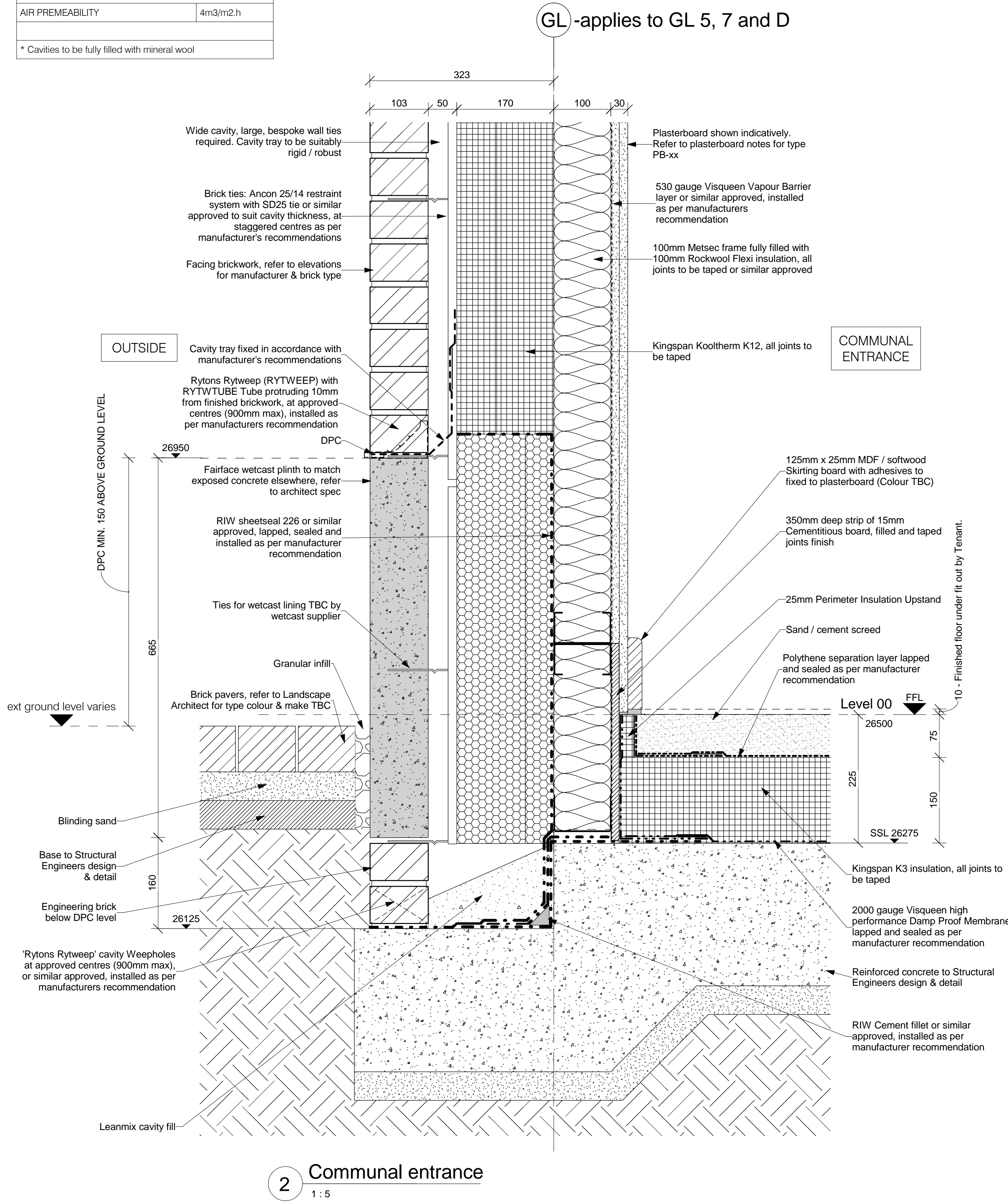

**2** Communal entrance  
1:5

GL - applies to GL 5, 7 and D

B	22.04.16	General amendments	RB	JR
A	04.01.16	Initial issue	RB	JR
Rev:	Date:	Description:	CRK:	Apr:

Scale @ A1: 1:5 | Issuing Office: London | Project No: 84923

Status: S2 | Purpose of Issue: Construction

**Ingleton Wood**  
Vision, form and function

London  
1 Alie Street  
London E1 8DE

Billericay  
Cambridge  
Colchester  
London  
Norwich

T: 020 7680 4400  
www.ingletonwood.co.uk

Project:  
Regents Park Estate  
Plot 3 - Varndell Street  
London  
NW1 3RG

Drawing Title:  
Ground Floor Details

Client:  
Lovell Partnership Ltd.