

**EXISTING FRONT AREA ARRANGEMENT**  
(RAILINGS/BALUSTRADING OMITTED FOR CLARITY)

CONSTRUCTION KEY	
	existing retained
	line over/under/behind
	demolished
	new construction

GROSS INTERNAL FLOOR AREAS:	
- Overall:	178.3 m <sup>2</sup>
- Communal Circulation:	0 m <sup>2</sup>
- Basement Flat:	40.9 m <sup>2</sup>
- Upper Maisonette:	137.4 m <sup>2</sup>

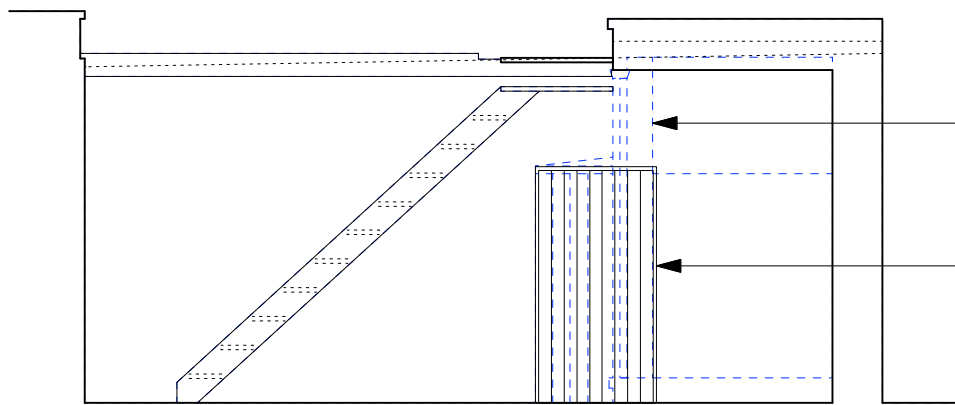

**PROPOSED FRONT AREA ARRANGEMENT**  
(RAILINGS/BALUSTRADING OMITTED FOR CLARITY)

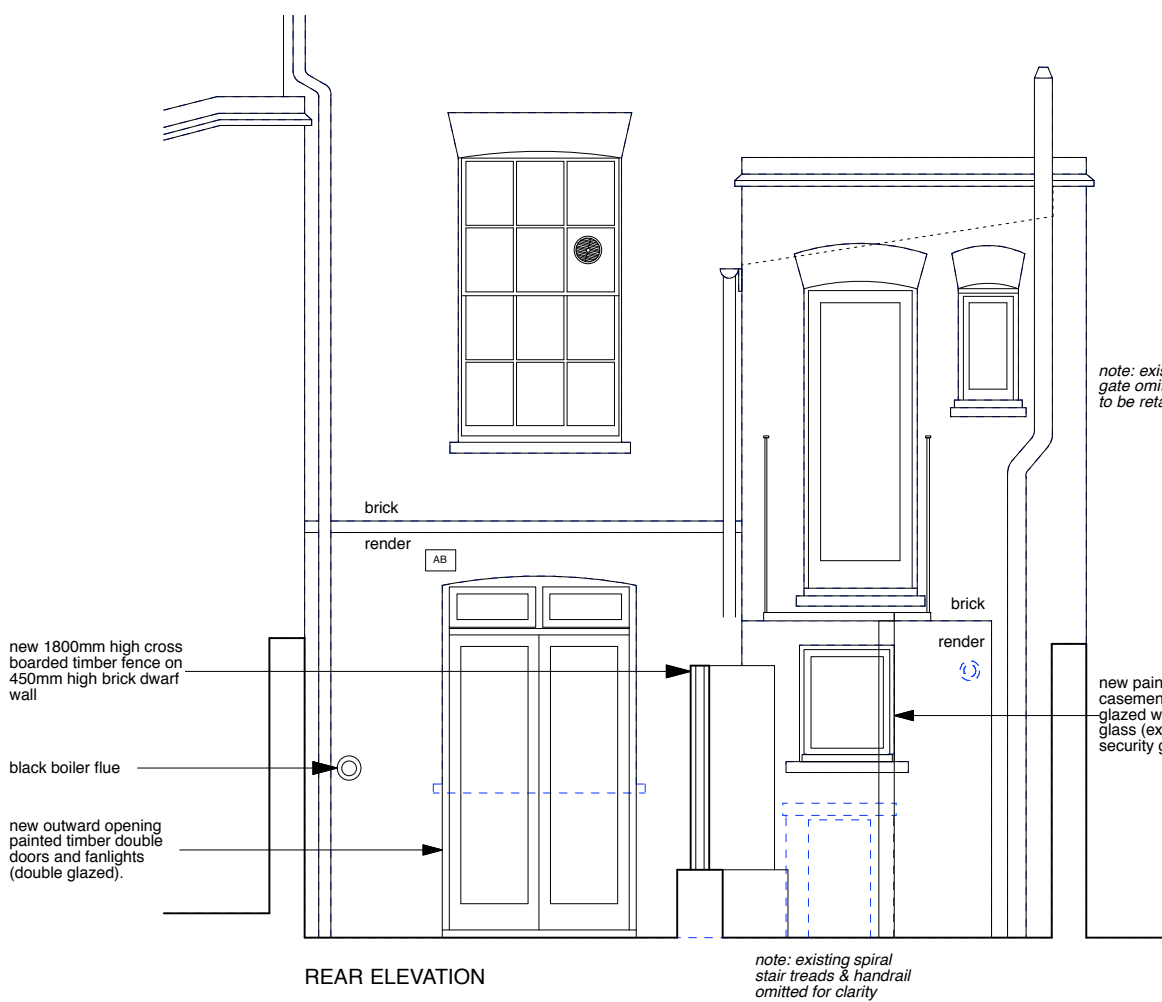

**REAR ELEVATION**

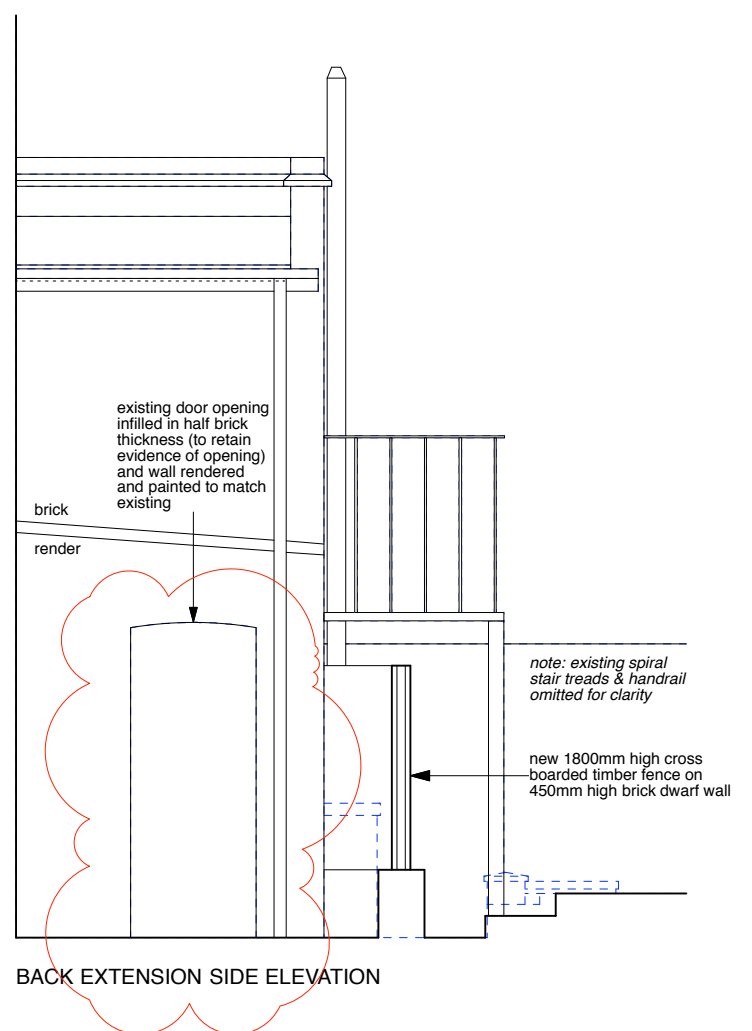

**BACK EXTENSION SIDE ELEVATION**

Rev B - 06/05/16 - as indicated  
Rev A - 14/03/16 - as indicated

	PROJECT 5 ARCHITECTURE LLP 8 Waterson Street London E2 8HL T: +44 (0)20 7739 9131 F: +44 (0)20 7739 3687 E: info@p5a.co.uk	job title <b>64 FREDERICK STREET, LONDON WC1X 0ND</b>	scale <b>1:50 @ A3</b>	drawn <b>SA</b>	drawing no. <b>6214-FS64-P08B</b>
	drawing <b>PROPOSED REAR ELEVATION (PART ONLY), REAR EXTENSION          SIDE ELEVATION &amp; FRONT AREA VAULT ACCESS</b>	date <b>JULY 2015</b>	checked <b>XX</b>		