



© Crown Copyright. All rights reserved (GLA100032379)(2009)

SURFACE MOUNTED PLATFORM

SANTANDER CYCLES

- NOTES:**
- All dimensions in millimetres.
 - As shown in plan view.
 - As laid level profile and falls shall coincide with the levels of adjacent surfaces.
 - All surfacing and sand bed shown are purely indicative and for illustration purposes only.
 - Length of platform is indicative only and may vary to fit size of site (See Briefing Note - Alternative Solutions or Surface Mounted Platform Foundation).

SITE NAME

VARIOUS

SITE NO:

VARIOUS

BOROUGH

VARIOUS

POSTCODE

VARIOUS

Drawn

SH

Scale

1:20 @ A3

Dwg. No.

CHS_L1

Checked

Date

10/03/10

Rev. G

Rev. Date

06/05/15

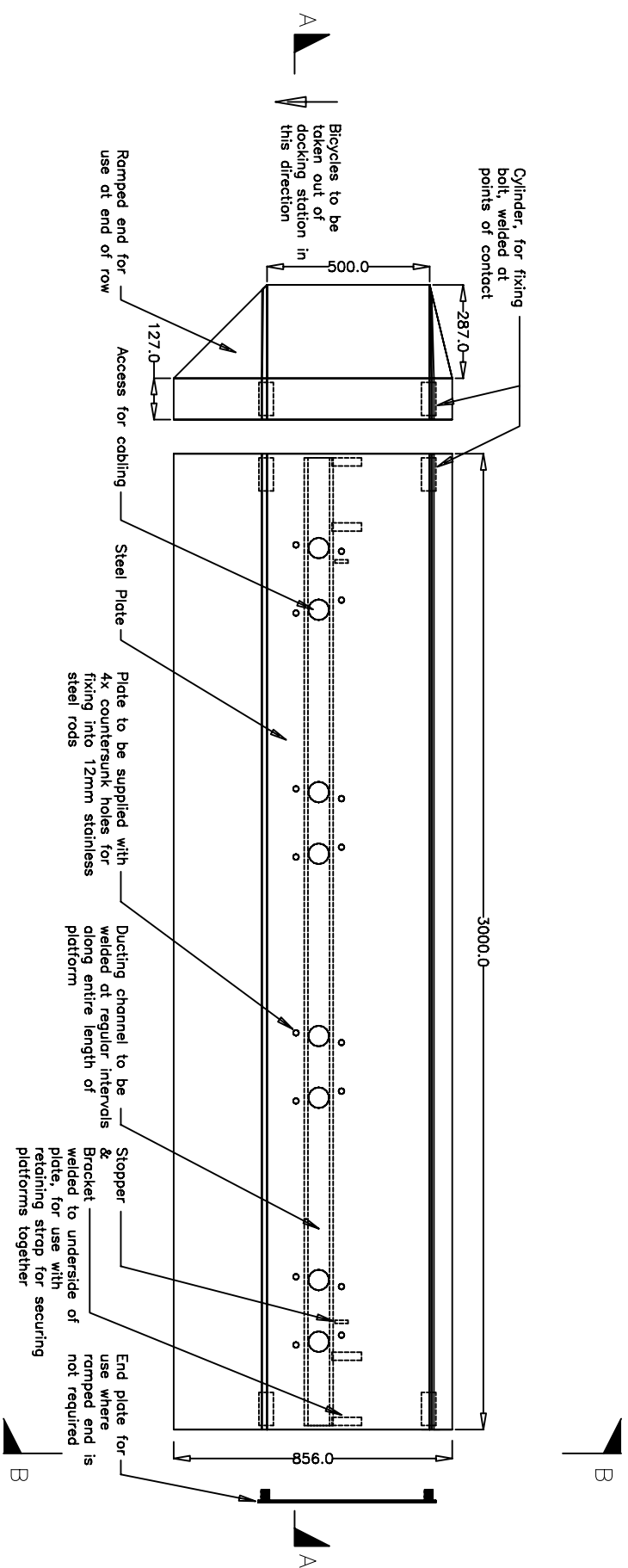

PLAN VIEW

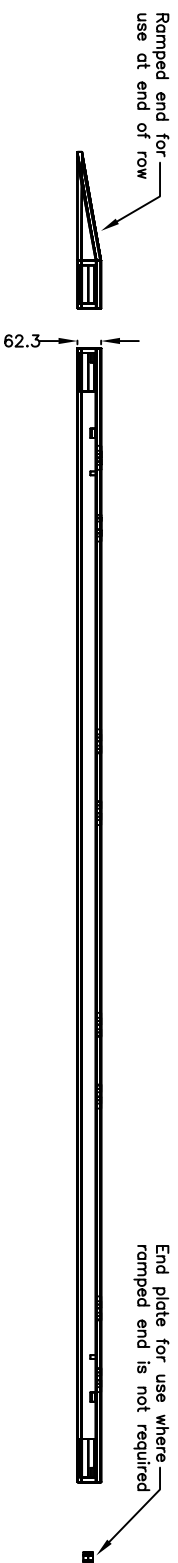

SECTION A-A

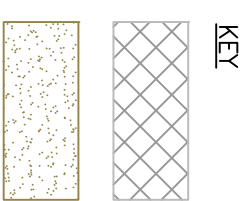

NOTE:
All surfacing and sand bed shown are purely indicative and for illustration purposes only.

- | | |
|----------|---|
| Material | - Structural Steel |
| Finish | - Dacrylate Margard
Easyclean AFP Finish |
| Colour | - RAL 7000 (75% grey in a
Satin course finish) |

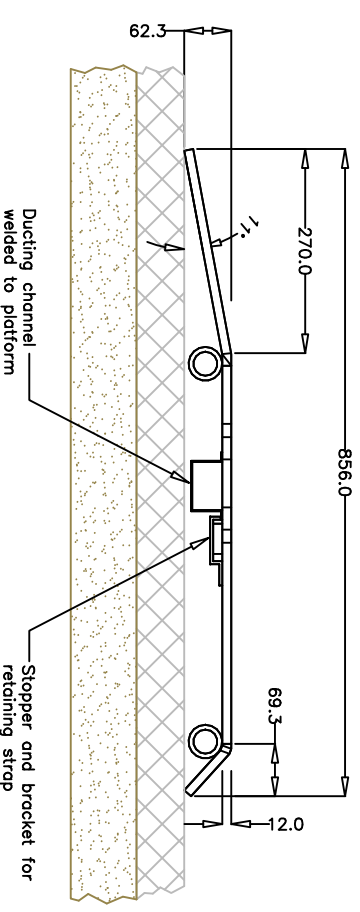

VIEW B-B
SCALE 1:10

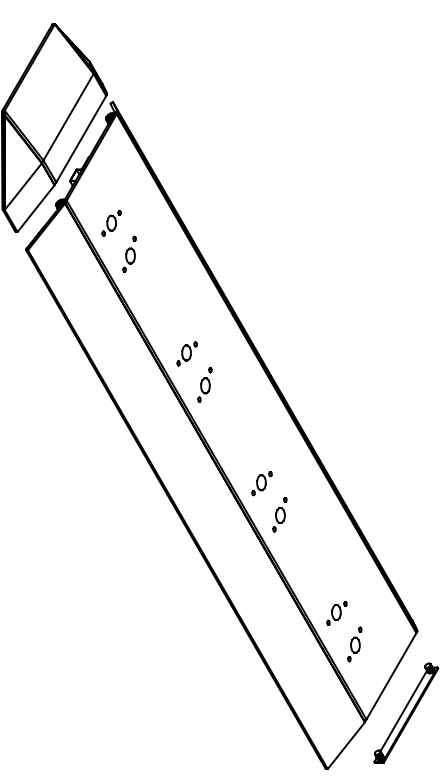

ISOMETRIC DIAGRAM
(FOR ILLUSTRATIVE PURPOSES ONLY)