

SECTION LINE BREAK

KEY PLAN

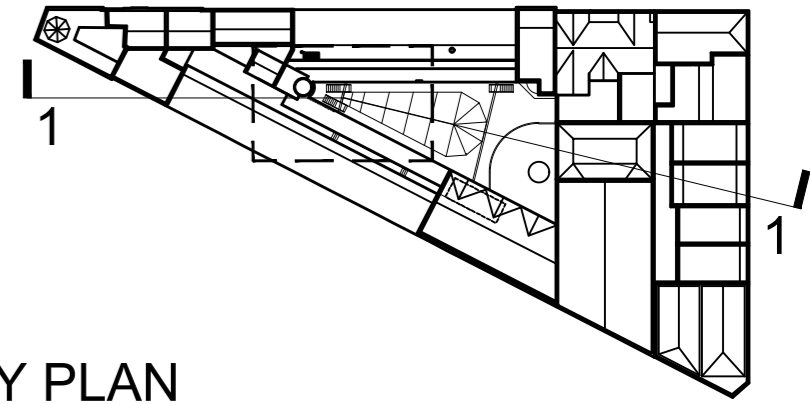

SILL LEVEL
30.170

ROOF SLAB
SSL 28.293

345

550

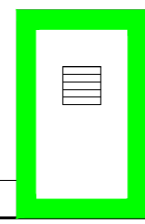

AC UNIT PROPOSED LOCATION

Rolfe Judd

Architecture Planning Interiors

Old Church Court, Claylands Road, The Oval, London SW8 1NZ

T 020 7556 1500

www.rolfe-judd.co.uk

NOTES Copyright Rolfe Judd Ltd

- 1 The Contractor must check and confirm all dimensions
- 2 All discrepancies must be reported and resolved by the Architect before works commence
- 3 This drawing is not to be scaled
- 4 All work and materials to be in accordance with current applicable Statutory Legislation and to comply with all relevant Codes of Practice and British Standards

Scale

This scale is 10cm in length when printed at the size indicated in the title block

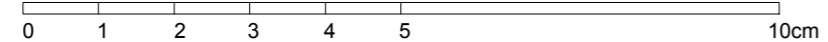

North Point

Rev continued

Date

Revision

- Preliminary Issue

Date

19/04/16

Client

Shaftesbury Covent Garden

Project

Thomas Neal's Centre
29 - 41 Earlam Street

Drawing

Proposed
Detail Section

Scale

1:20 (A2)

Date

Apr 16

Status

Preliminary

Job Number

5689

Drawing Number

T(20) D02

Revision

-

G:\5689\T_Series\T20\1604 AC Planning Application\T20D02