

SECTION LINE BREAK

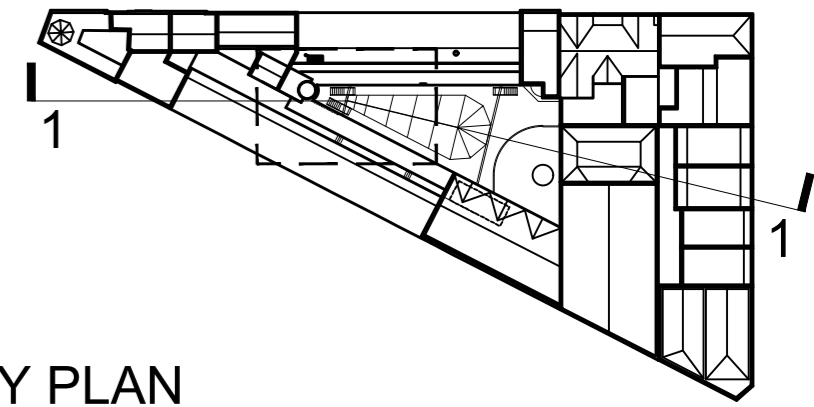

KEY PLAN

SILL LEVEL
30.170

ROOF SLAB
SSL 28.293

Rolfe Judd

Architecture Planning Interiors
Old Church Court, Claylands Road, The Oval, London SW8 1NZ
T 020 7556 1500
www.rolfe-judd.co.uk

- NOTES
- 1 The Contractor must check and confirm all dimensions
 - 2 All discrepancies must be reported and resolved by the Architect before works commence
 - 3 This drawing is not to be scaled
 - 4 All work and materials to be in accordance with current applicable Statutory Legislation and to comply with all relevant Codes of Practice and British Standards

Copyright Rolfe Judd Ltd

Scale

This scale is 10cm in length when printed at the size indicated in the title block

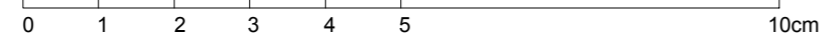

North Point

Rev continued

Date

Revision
- Preliminary Issue

Date
19/04/16

Client
Shaftesbury Covent Garden

Project
Thomas Neal's Centre
29 - 41 Earham Street

Drawing
Existing
Detail Section

Scale	Date	Status
1:20 (A2)	Apr 16	Preliminary
Job Number	Drawing Number	Revision
5689	T(10) D02	-

G:\5689\T_Series\T10\1604 AC Planning Application\T10D02