

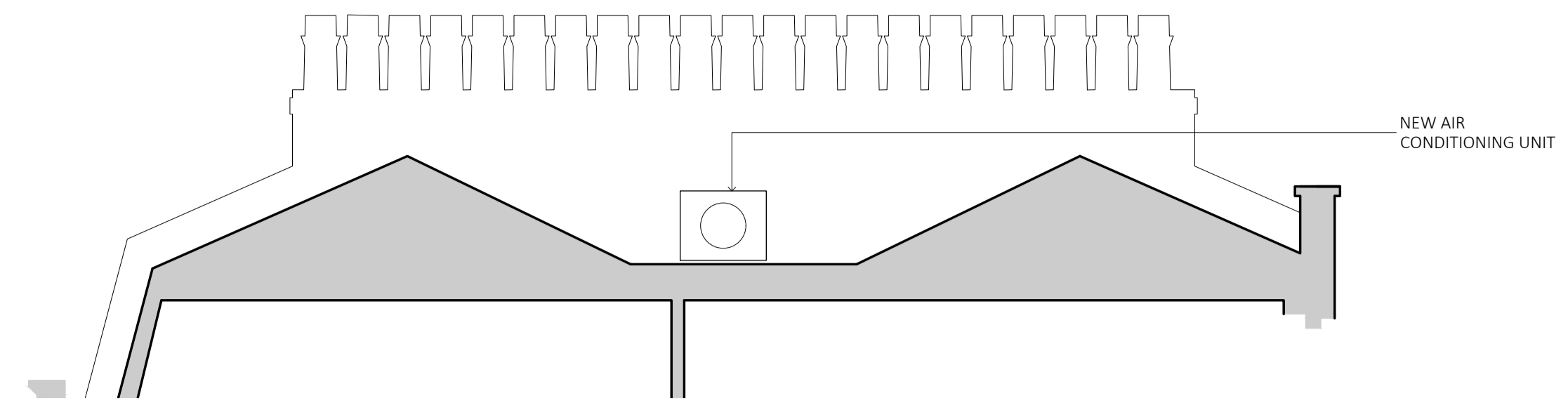

SECTION C-C

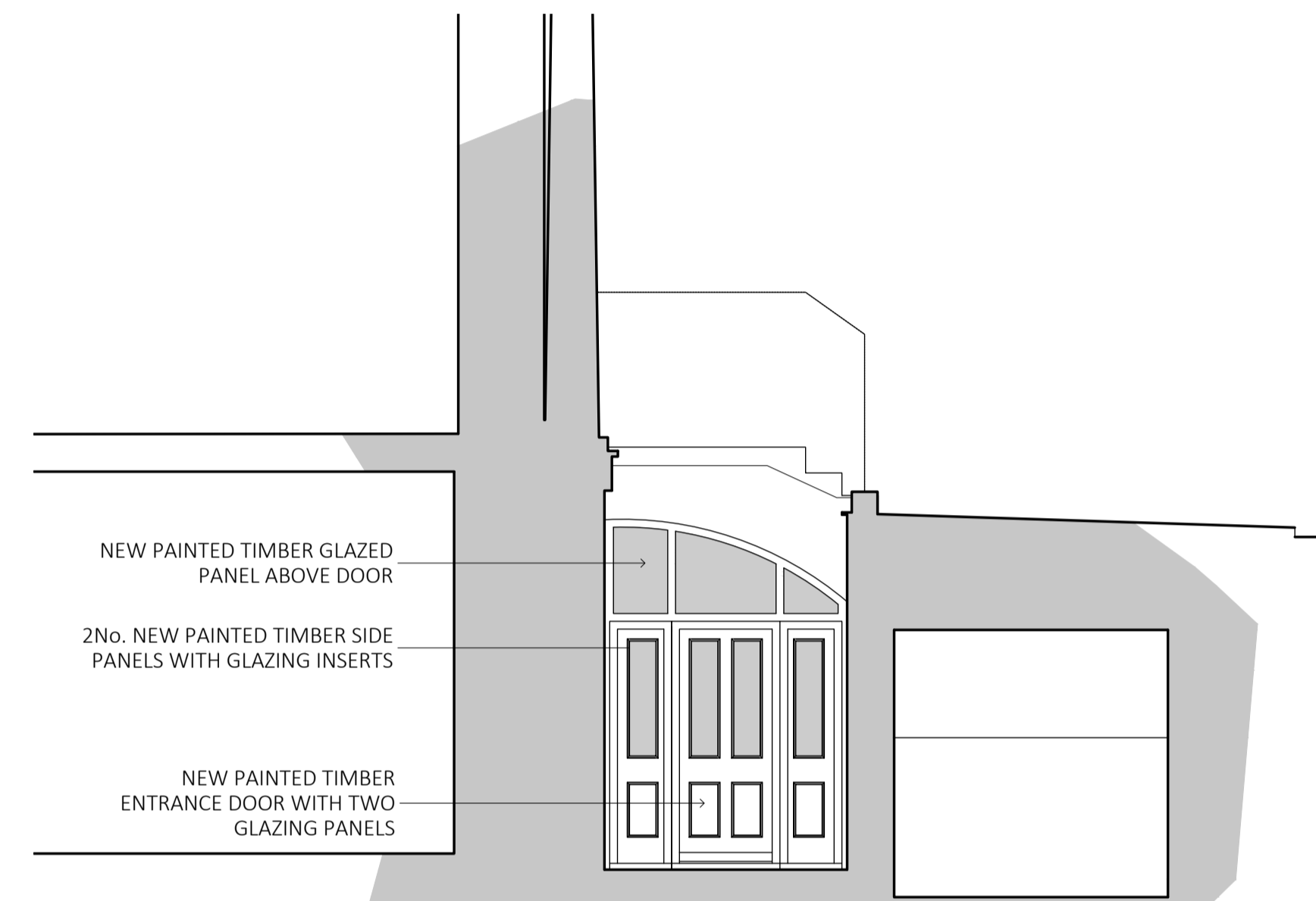

ELEVATION C (PROPOSED AIR CONDITIONING UNIT)



ELEVATION B (PROPOSED DOOR)

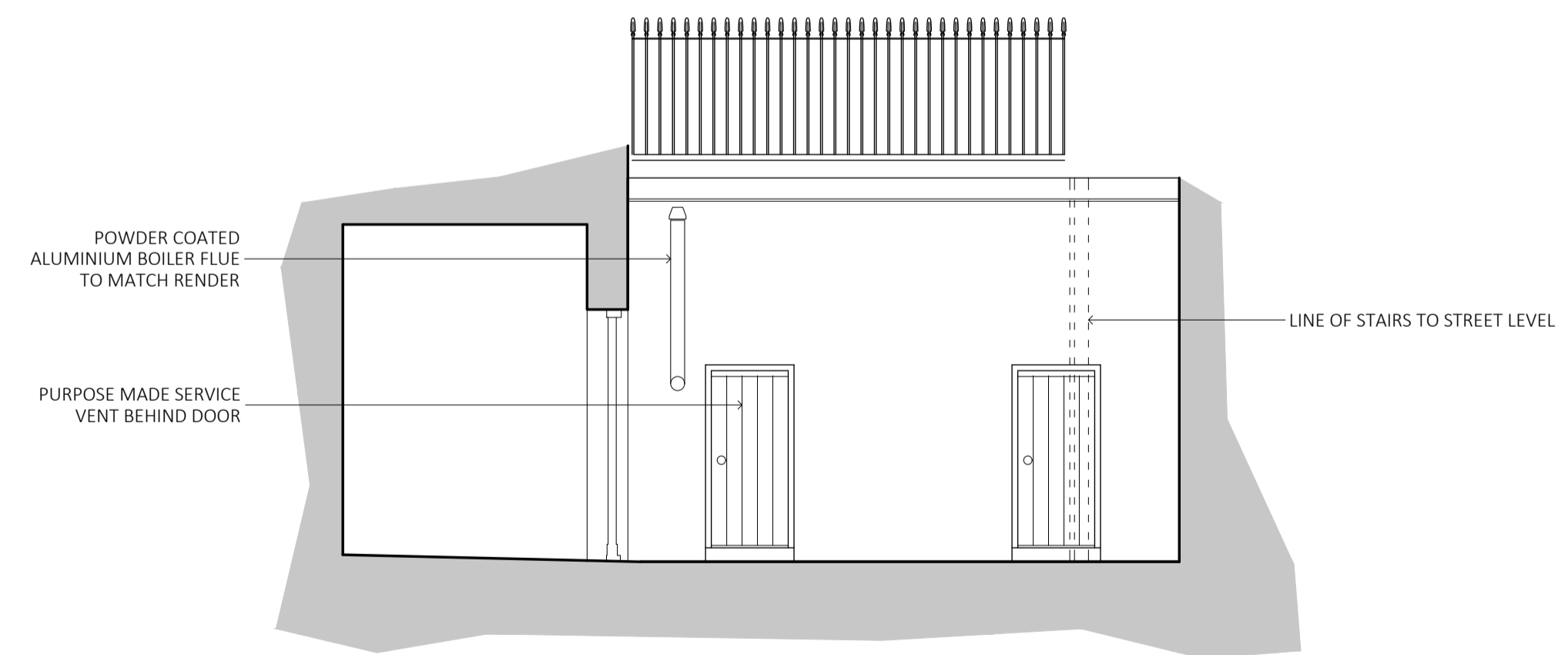

ELEVATION A (VAULT ENTRANCES)

**BB PARTNERSHIP** LTD  
CHARTERED ARCHITECTS

Studios 33-34, 10 Hornsey St, London. N7 8EL  
Tel 020 7336 8555 - e-mail - architect@bbpartnership.co.uk

client  
Amit & Devika Chadha

project  
15 Park Square East,  
London  
NW1 4LH  
Project

drawing  
Elevations and sections  
as proposed

date	scale	drawn by
12/04/16	1:50 at A1	JC

drg.no.	revision
FOD_207	-