

27 GROVE TERRACE CONDITIONS DOCUMENT

PLANNING REFERENCE

REF: 2015/3002/L

REF: 2015/0323/L



PHOTO 1 - Head and sash stile (right) and meeting rail (left)
Profiles have been chosen to match the existing windows to the rear of the house.

SAMPLE SECTIONS ONLY
SET OUT AS SHOWN ON APPROVED
PLANNING DWG. ELEVATIONS



PHOTO 2 - Bottom rail (left) and glazing bar (right)

PLANNING REFERENCE
REF: 2015/3002/L
REF: 2015/0323/L

27 GROVE TERRACE, NWS
MANSARD FRONT WINDOWS
TIMBER SECTIONS

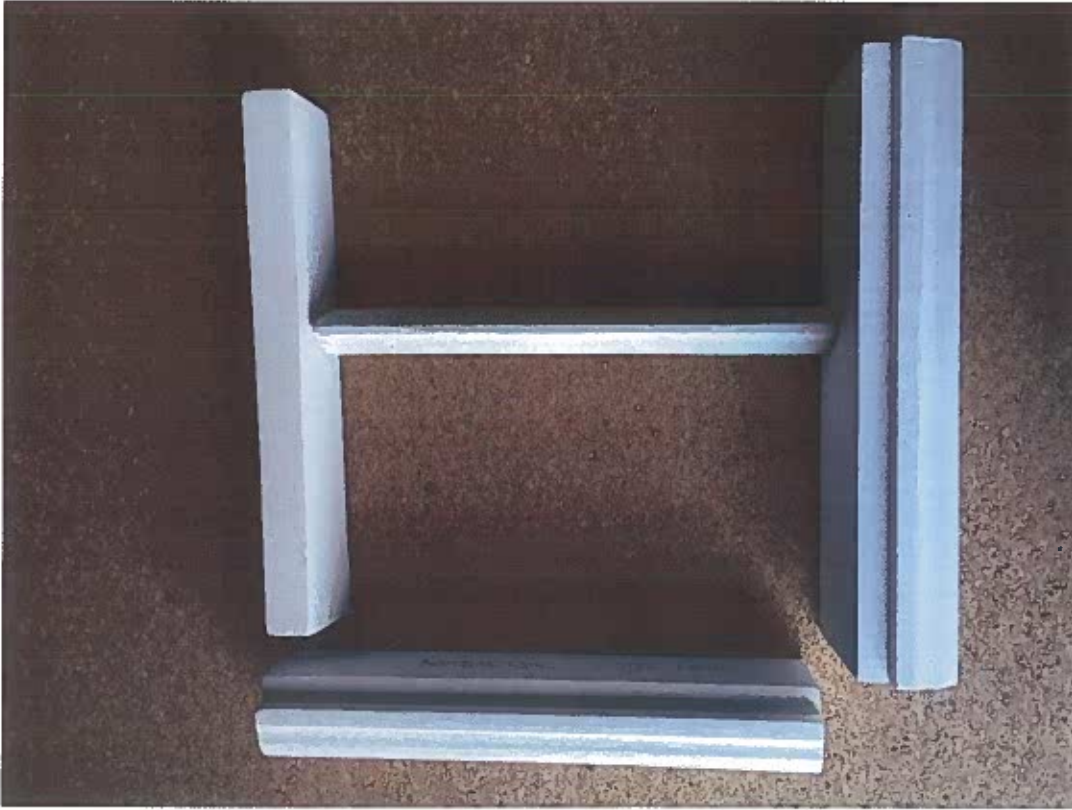

PHOTO 3 All frames from above – front elevation
 Profiles have been chosen to match the existing windows to
 the front of the house.

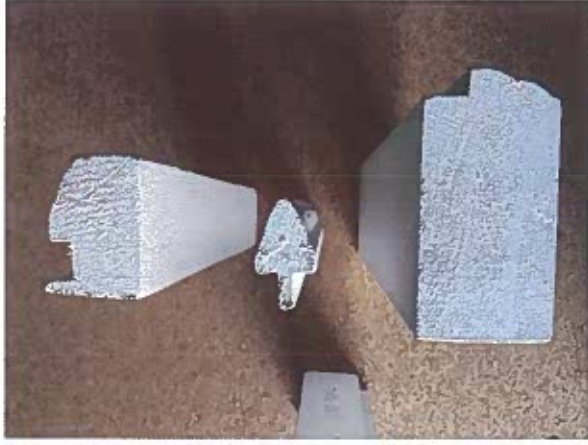

PHOTO 4 Bottom rail, glazing bar,
 sash meeting rail from bottom to top

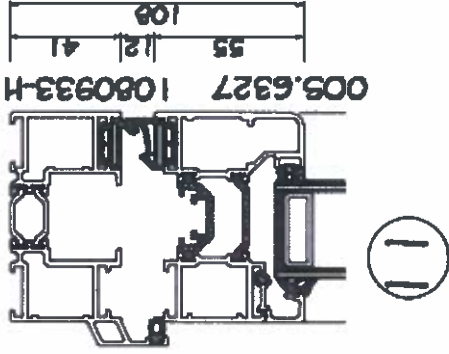

PHOTO 5 - Section of side rail

SAMPLE SECTIONS ONLY
 SET OUT AS SHOWN ON APPROVED
 PLANNING DWG. ELEVATIONS

PLANNING REFERENCE
 REF: 2015/3002/L
 REF: 2015/0323/L

27 GROVE TERRACE, NW5
 REPLACEMENT REAR WINDOWS
 TIMBER SECTIONS



Section of frame at head

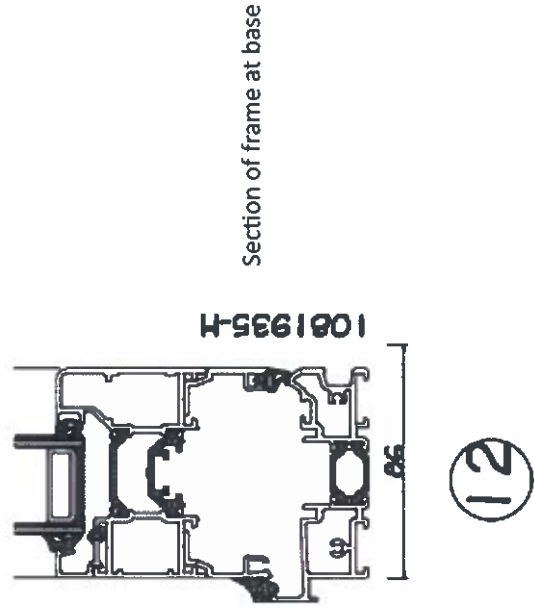

Section of frame at base

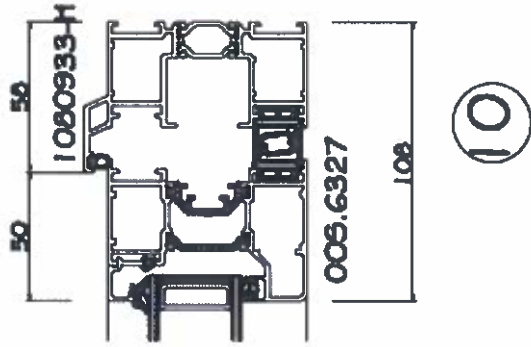

Plan of frame to right

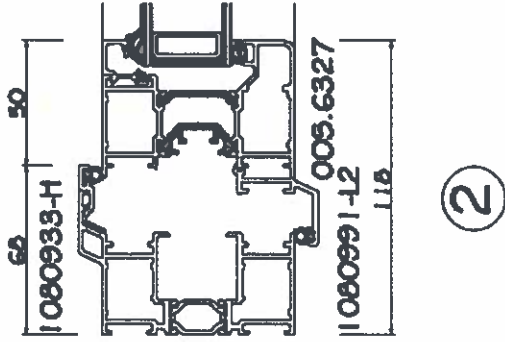

Plan of frame to left

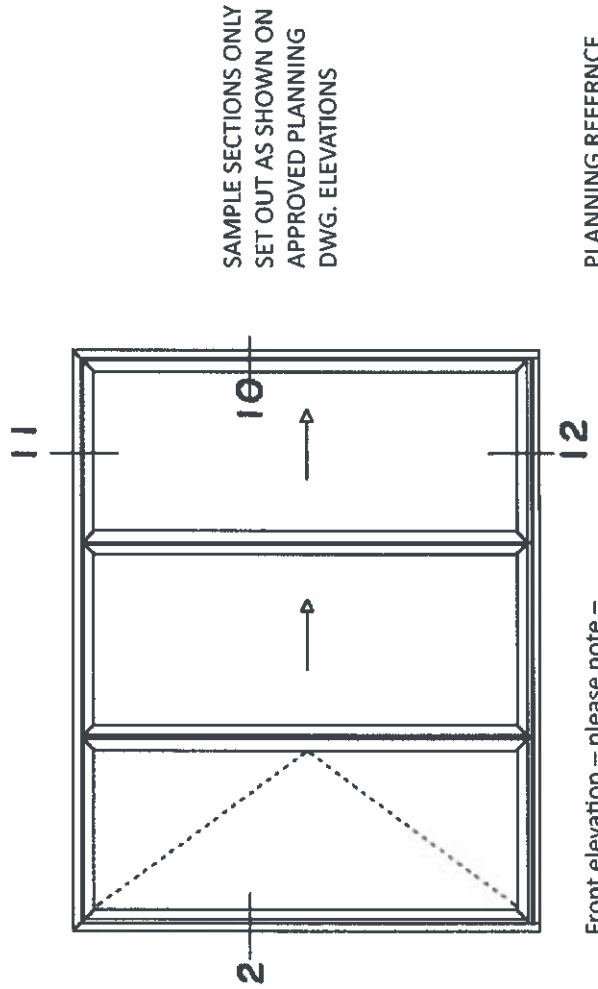

Front elevation -- please note -- single door only

PLANNING REFERENCE
REF: 2015/3002/L
REF: 2015/0323/L

27 GROVE TERRACE, NW5
CLOSET WING SINGLE DOOR
TO GARDEN AT REAR OF HOUSE

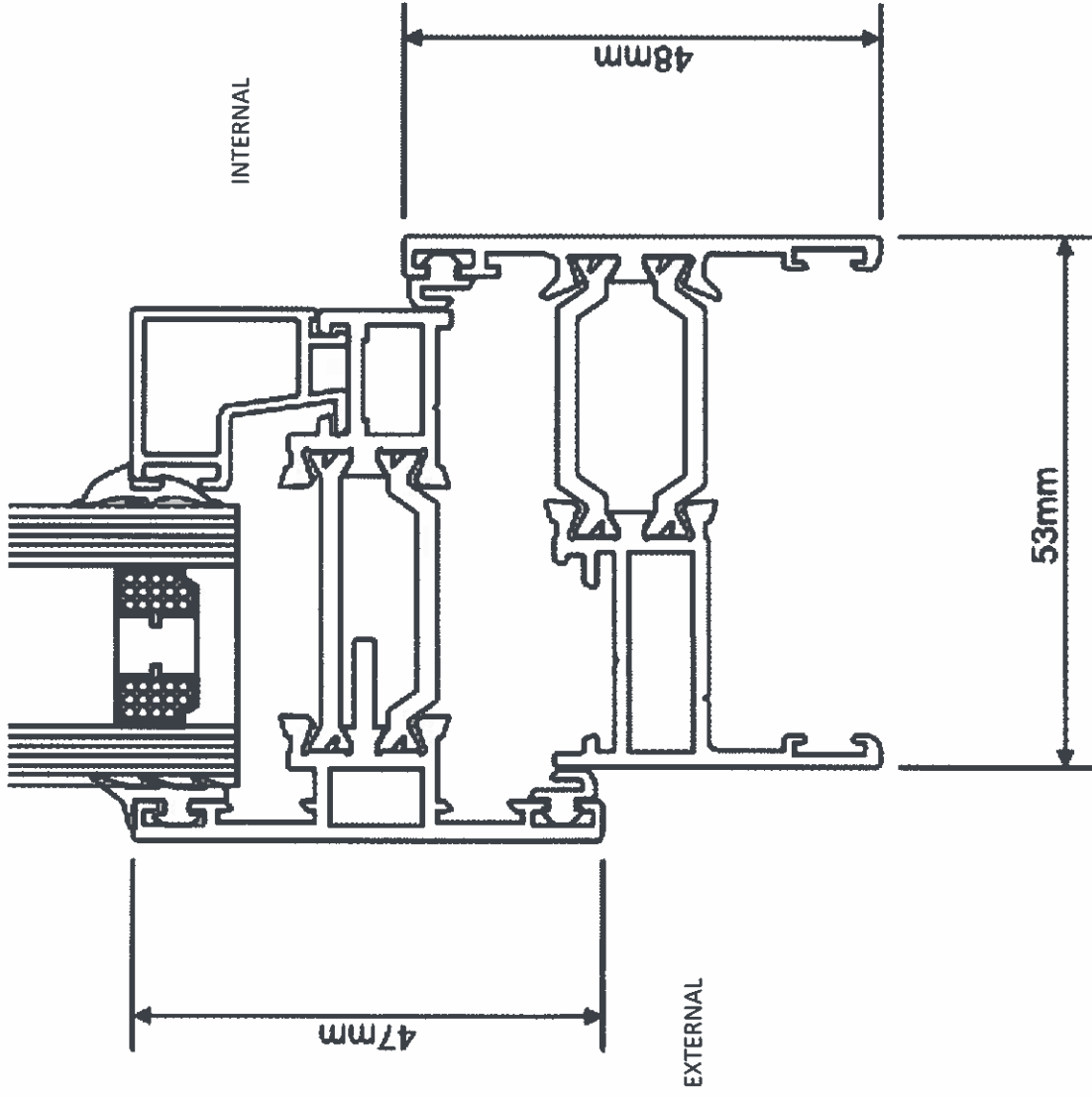

The external side is the 47mm.
The section under the 47mm is
approx. 15mm & will be concealed
in the wall.

SAMPLE SECTIONS ONLY
SET OUT AS SHOWN ON APPROVED
PLANNING DWG. ELEVATIONS

PLANNING REFERENCE
REF: 2015/3002/L
REF: 2015/0323/L

27 GROVE TERRACE, NW5
CLOSET WING SMALL SIDE WINDOW
AT REAR OF HOUSE



PHOTO 6 – Mortar sample

PHOTO OF SAMPLE
SEE ATTACHED DATA SHEET
FOR LIME MORTAR

PLANNING REFERENCE
REF: 2015/3002/L
REF: 2015/0323/L

27 GROVE TERRACE, NW5
FACING MATERIAL – MORTAR
SAMPLE SECTION FOR REAR OF PROPERTY



PHOTO 7 – Ventilation grill to bathroom
Rear wall, positioned between waste pipes



PHOTO 9 – Boiler outlet
To side wall – recessed position



PHOTO 8 – Ventilation grill to bathrooms
In roof, positioned behind chimney to mansard
and London roof – not seen from either front or rear
At ground level

EXAMPLES OF GRILLES

PLANNING REFERENCE
REF: 2015/3002/L
REF: 2015/0323/L

27 GROVE TERRACE, NW5
EXAMPLES OF GRILLES