

KEY

	RESERVED MATTERS SUBMISSION BOUNDARY
	SEMI-MATURE TREE
	SHRUB / HERBACEOUS PLANTING
	HEDGE PLANTING
	CONCRETE AND TIMBER TOPPED BENCH
	CONCRETE AND TIMBER TOPPED EMERGENCY VEHICULAR RESTRAINT
	FREESTANDING METAL PLANTERS

1 No. Platanus acerifolia
Girth: 45-50cm

FOR APPROVAL

Project WHARF ROAD VIADUCT AND COAL DROPS RAMP	Drawing Title PUBLIC REALM PLANTING PLAN	Revision R00 -	Date 17.01.14	R05 - Layout updated 	Date 31.03.16	Client KING'S CROSS CENTRAL GENERAL PARTNER LTD Address: 4 Stable Street, King's Cross, London, N1C 4AB Telephone: 020 3664 0200	Consultant TOWNSHEND Landscape Architects Unit 1E Zetland House London EC2A 4HJ Telephone: 020 7729 9333 Fax: 020 7729 3300 E-Mail: ita@townshenda.com	Project No. 279.14	Scale 1:250@A1/ 1:500@A3	Approved By MA	Drawing No. 279.14(08)3001	Revision R06
		R01 - Key annotation amendments	Date 24.01.14	R06 - Number of bollards amended	Date 19.04.16			Date JUNE '14	Drawing Size A1	Drawn By MK		
		R02 - Text amended	Date 03.06.14									
		R03 - Retaining wall updated	Date 05.06.14									
		R04 - Step layout amended	Date 03.07.14									

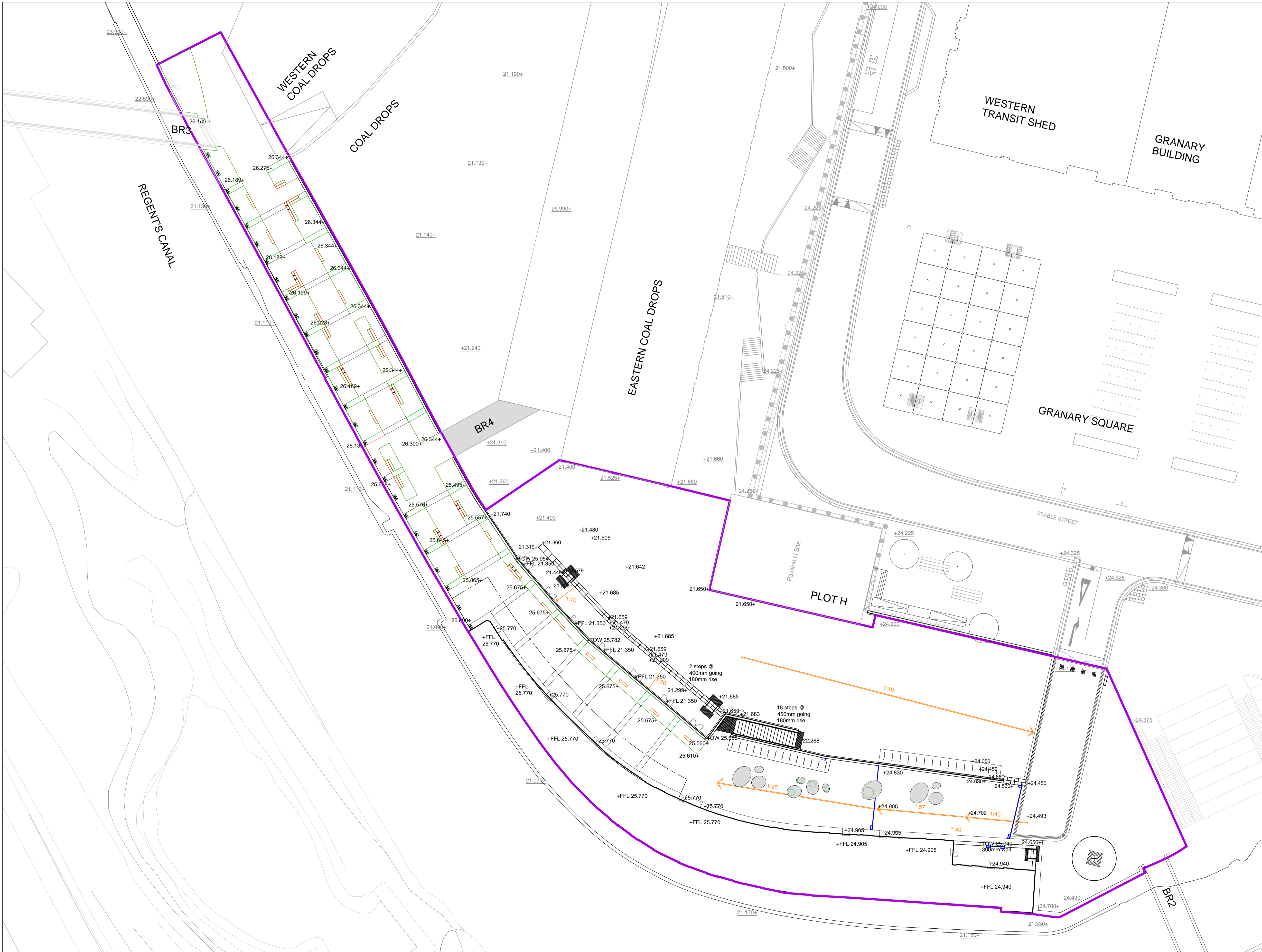

KEY

	RESERVED MATTERS SUBMISSION BOUNDARY
	EXISTING LEVELS
	PROPOSED LEVELS
	GRADIENTS
	SLOT DRAIN

FOR APPROVAL

Project WHARF ROAD VIADUCT AND COAL DROPS RAMP	Drawing Title PUBLIC REALM SURFACE LEVELS PLAN	Revision R00 - PLANNING ISSUE	Date 14.01.14	R05 - Steps layout amended 03.07.14	Client KING'S CROSS CENTRAL GENERAL PARTNER LTD Address: 4 Stable Street, King's Cross, London, N1C 4AB Telephone: 020 3664 0200	Consultant TOWNSHEND Landscape Architects Unit 1E Zetland House London EC2A 4HJ Telephone: 020 7729 9333 Fax: 020 7729 3300 E-Mail: ita@townshenda.com	Project No. 279.14	Scale 1:250@A1/ 1:500@A3	Approved By MA	Drawing No. 279.14(08)5002	Revision R07
		R01 - Levels minor amendments 24.01.14	R06 - Levels amended 31.03.16	Date JUNE '14			Drawing Size A1	Drawn By MK			
		R02 - Ground Floor spill out area amended 27.02.14	R07 - Levels and Key amended 19.04.16								
		R03 - Text amended 03.06.14									
		R04 - Level amended 05.06.14									

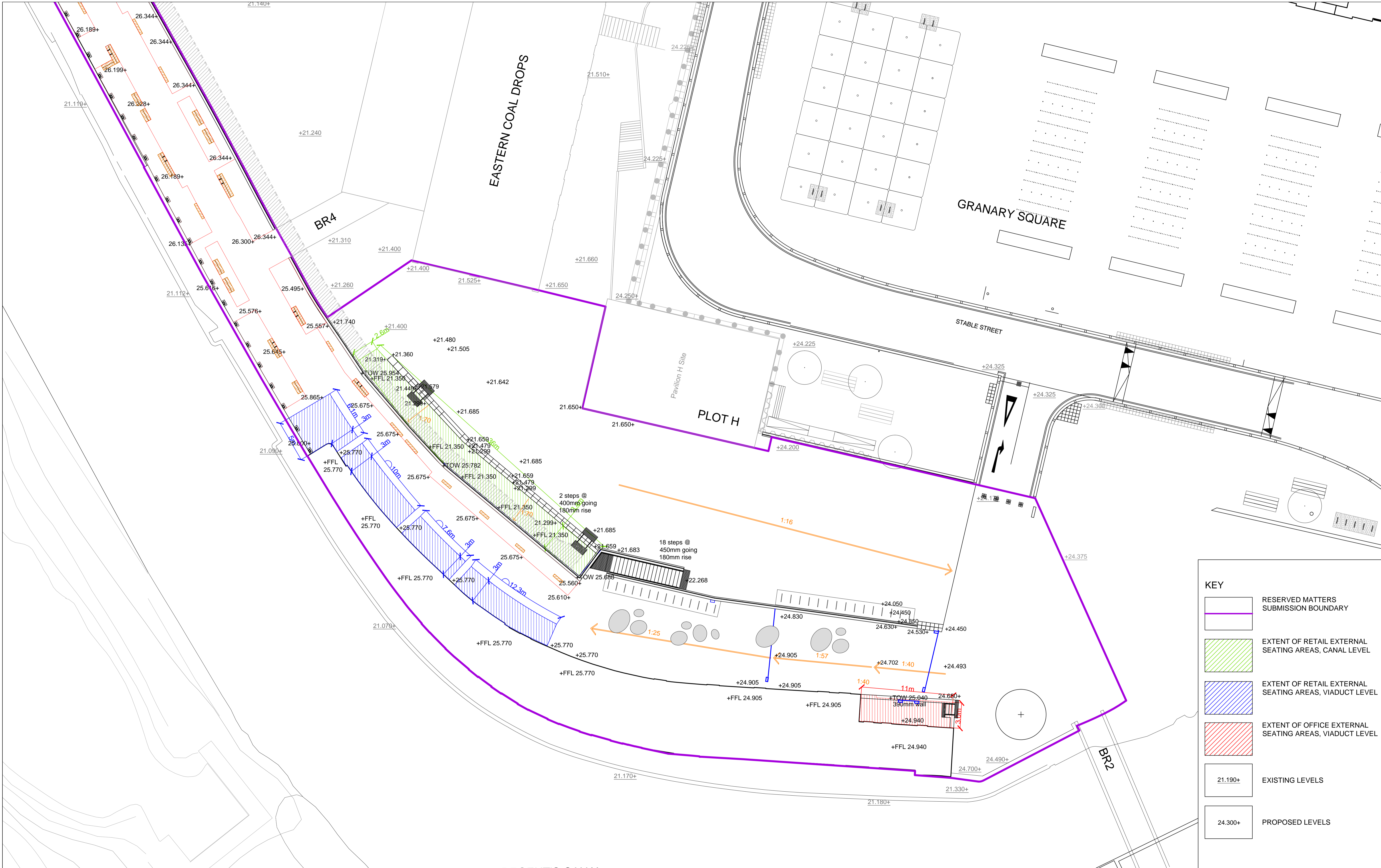

KEY	
	RESERVED MATTERS SUBMISSION BOUNDARY
	EXTENT OF RETAIL EXTERNAL SEATING AREAS, CANAL LEVEL
	EXTENT OF RETAIL EXTERNAL SEATING AREAS, VIADUCT LEVEL
	EXTENT OF OFFICE EXTERNAL SEATING AREAS, VIADUCT LEVEL
	EXISTING LEVELS
	PROPOSED LEVELS

Project WHARF ROAD VIADUCT AND COAL DROPS RAMP	Drawing Title RETAIL EXTERNAL SEATING AREAS	Revision R01 - Extent of seating area amended R02 - Landscape and extent of seating areas amended R03 - Spot heights added following comments R04 - Levels updated R05 - Layout updated	Date 27.09.13 09.12.13 09.12.13 05.06.14 31.03.16	R06 - Levels and Key amended 19.04.16	Client KXC GENERAL PARTNER LTD Address: 4 Stable Street, King's Cross, London, N1C 4AB Telephone: 020 3664 0200	Consultant TOWNSHEND Landscape Architects Unit 1E Zetland House London EC2A 4HJ Telephone: 020 7729 9333 Fax: 020 7729 3300 E-Mail: ita@townshenda.com	Project No. 279.14	Scale 1:200@A1/ 1:400@A3	Approved By MA	Drawing No. 279.14(08)5005	Revision R06
							Date JUNE 14	Drawing Size A1	Drawn By MK		

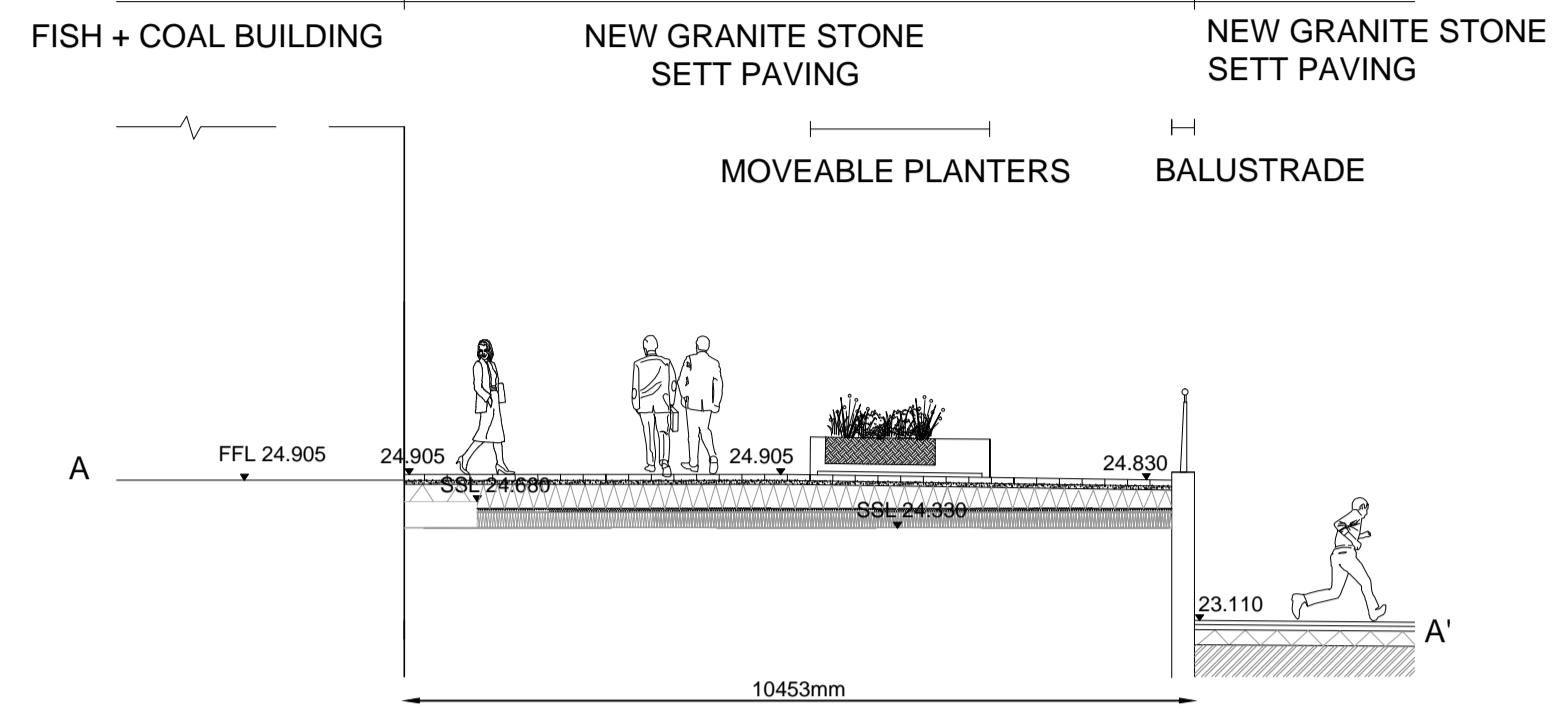

SECTION AA'
SCALE 1:100

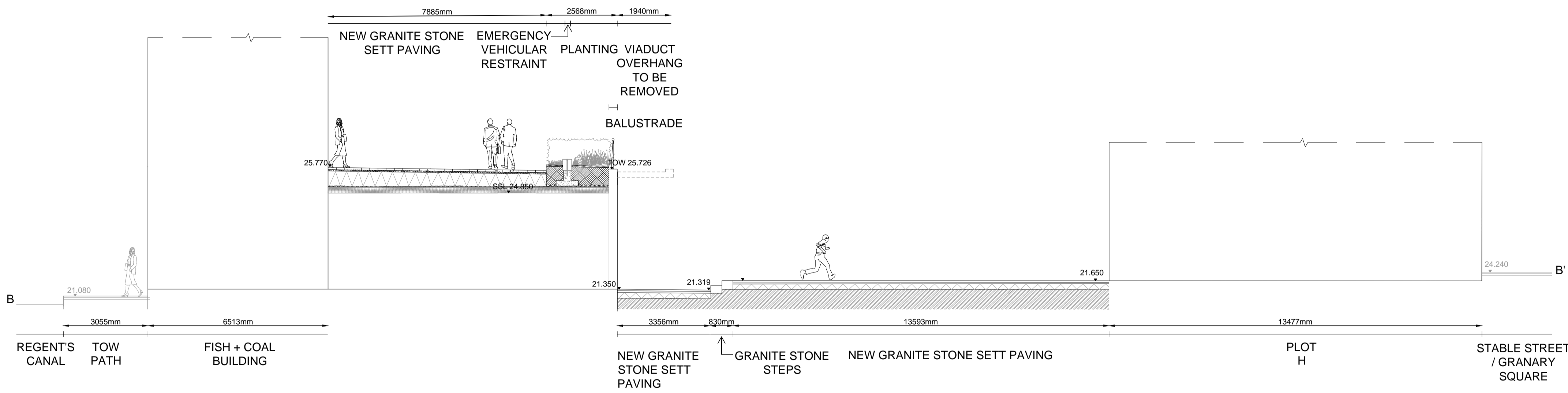

SECTION BB'
SCALE 1:100

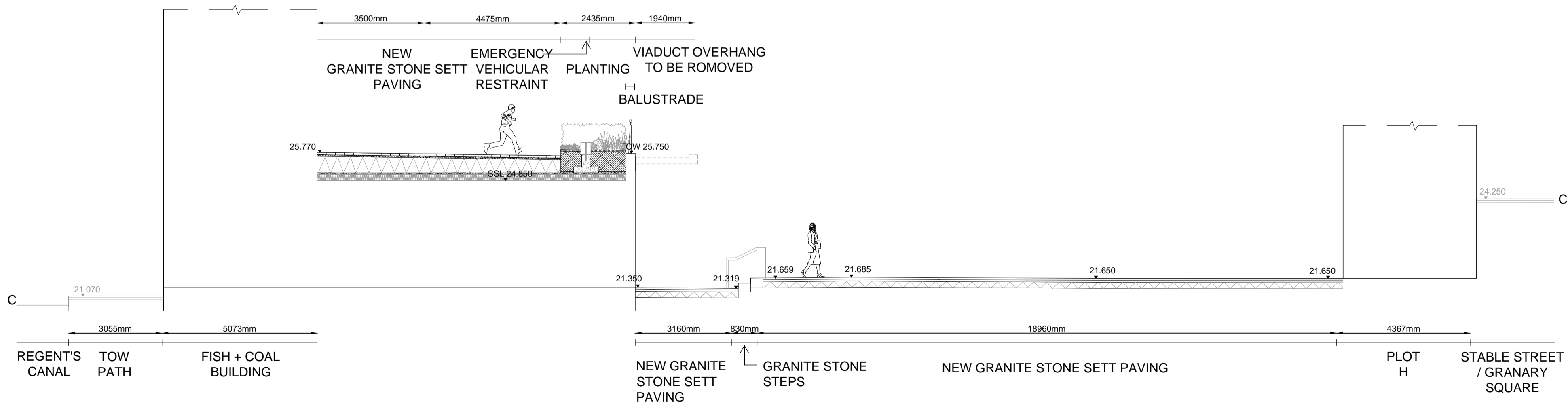

SECTION CC'
SCALE 1:100

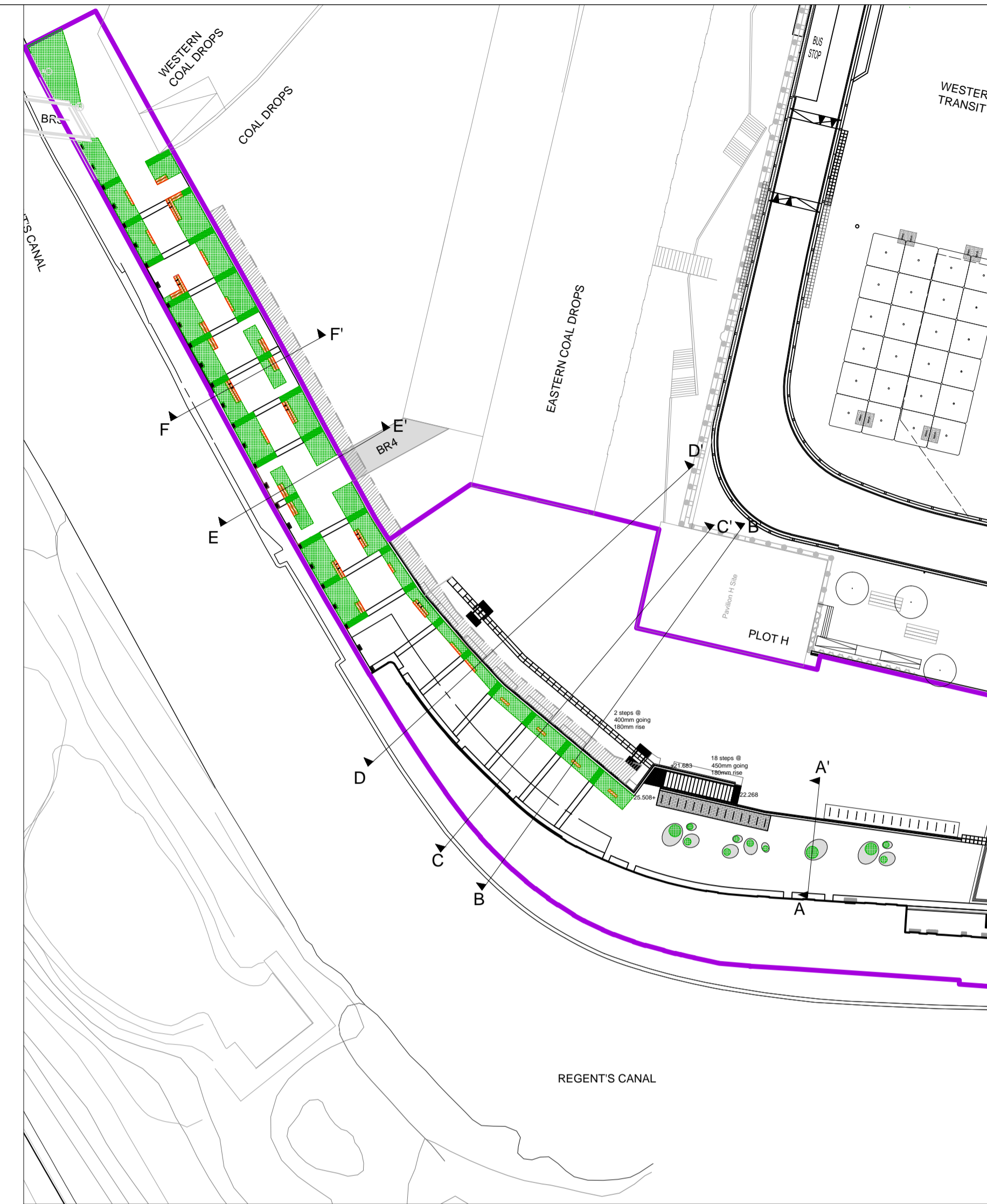

LOCATION PLAN
1:500@A1 / 1:1000@A3

FOR APPROVAL

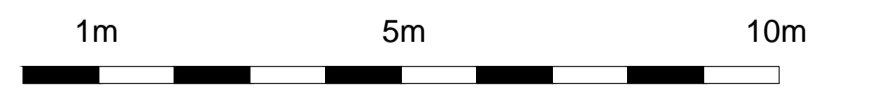

Project WHARF ROAD VIADUCT AND COAL DROPS RAMP	Drawing Title PUBLIC REALM LANDSCAPE SECTIONS AA', BB' & CC'	Revision	Date	R06 - Sections amended	24.01.14	Client KING'S CROSS CENTRAL GENERAL PARTNER LTD Address: 4 Stable Street, King's Cross, London, N1C 4AB Telephone: 020 3664 0200	Consultant TOWNSHEND Landscape Architects Unit 1E Zetland House London EC2A 4HJ Telephone: 020 7729 9333 Fax: 020 7729 3300 E-Mail: ita@townshenda.com	Project No.	Scale	Approved By	Drawing No. TOWN279.14(08)7001	Revision R11
		R01 - Central steps removed	11.11.13	R07 - Text amended	03.06.14			279.14	1:100@A1/ 1:200@A3	MA		
		R02 - Viaduct build ups amended	15.11.13	R08 - Section A-A' levels amended	05.06.14			Date	A1	MK		
		R03 - Viaduct hard and soft landscape amended	25.11.13	R09 - Granite Sett Tags amended	25.09.14			JUNE '14				
		R04 - Bespoke seat added to conclude lower steps	05.12.13	R10 - Tags amended	31.03.16							
		R05 - Viaduct hard and soft landscape amended	14.01.14	R11 - Top of wall levels amended	19.04.16							

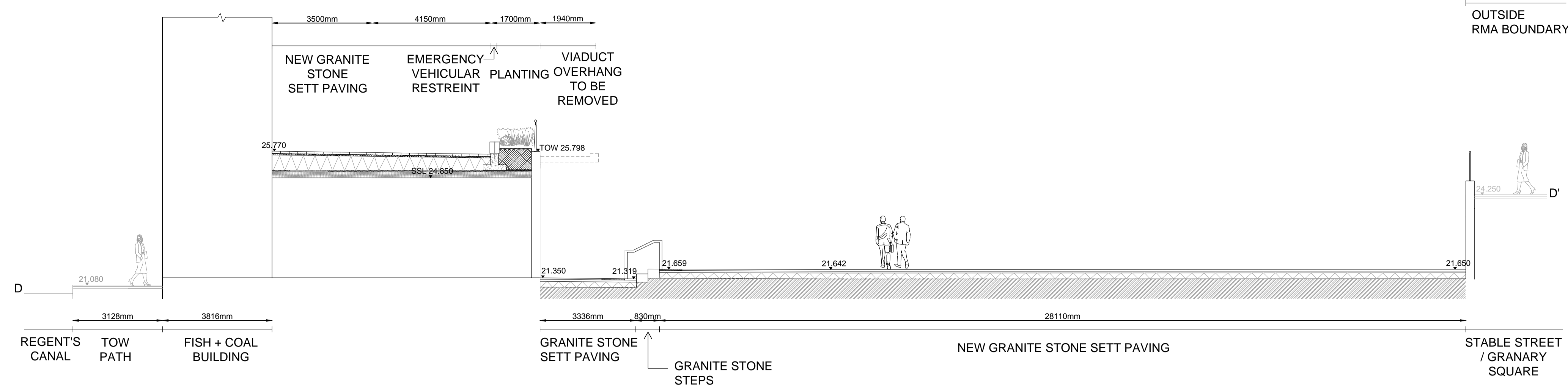

SECTION DD'
SCALE 1:100

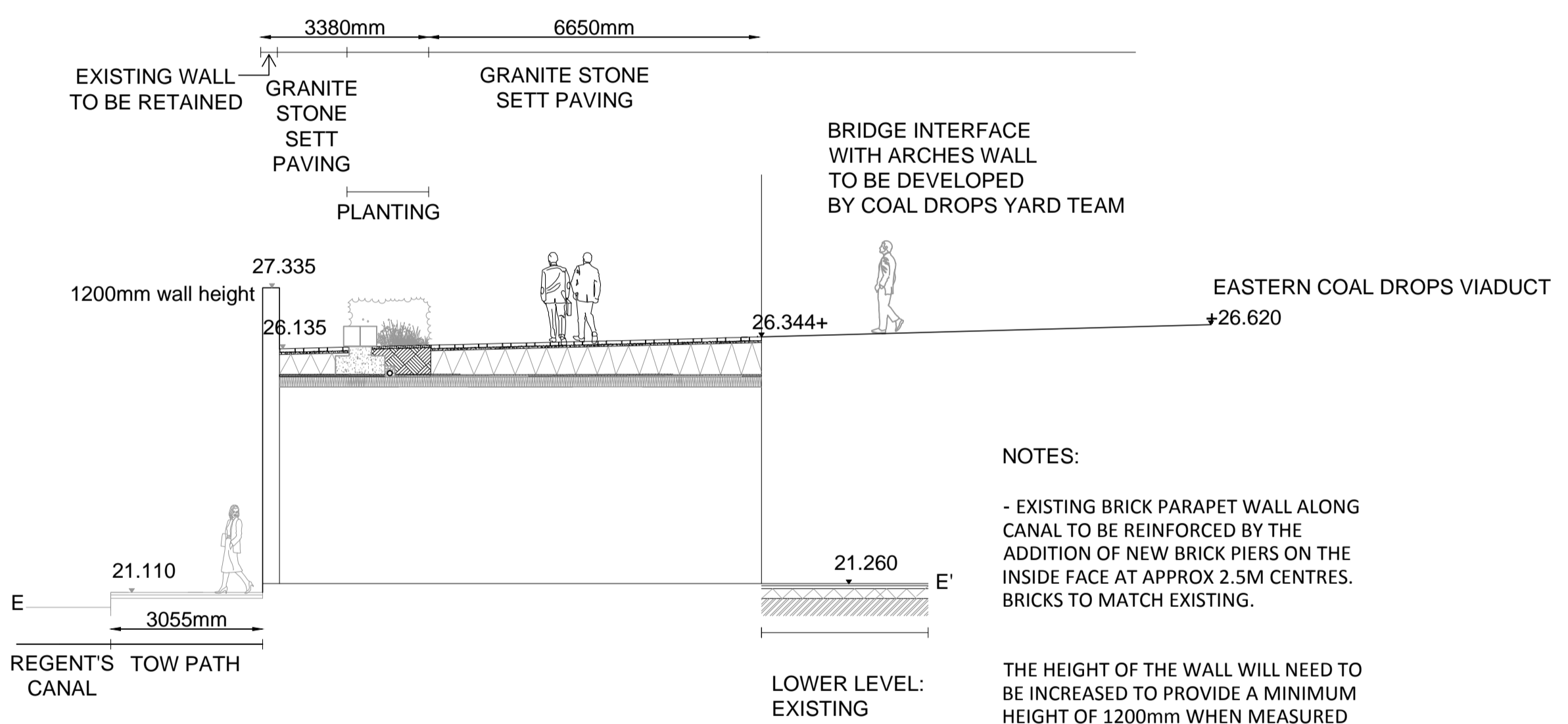

SECTION EE'
SCALE 1:100

NOTES:
- EXISTING BRICK PARAPET WALL ALONG CANAL TO BE REINFORCED BY THE ADDITION OF NEW BRICK PIERS ON THE INSIDE FACE AT APPROX 2.5M CENTRES. BRICKS TO MATCH EXISTING.
THE HEIGHT OF THE WALL WILL NEED TO BE INCREASED TO PROVIDE A MINIMUM HEIGHT OF 1200mm WHEN MEASURED FROM THE VIADUCT FINISHED LEVEL

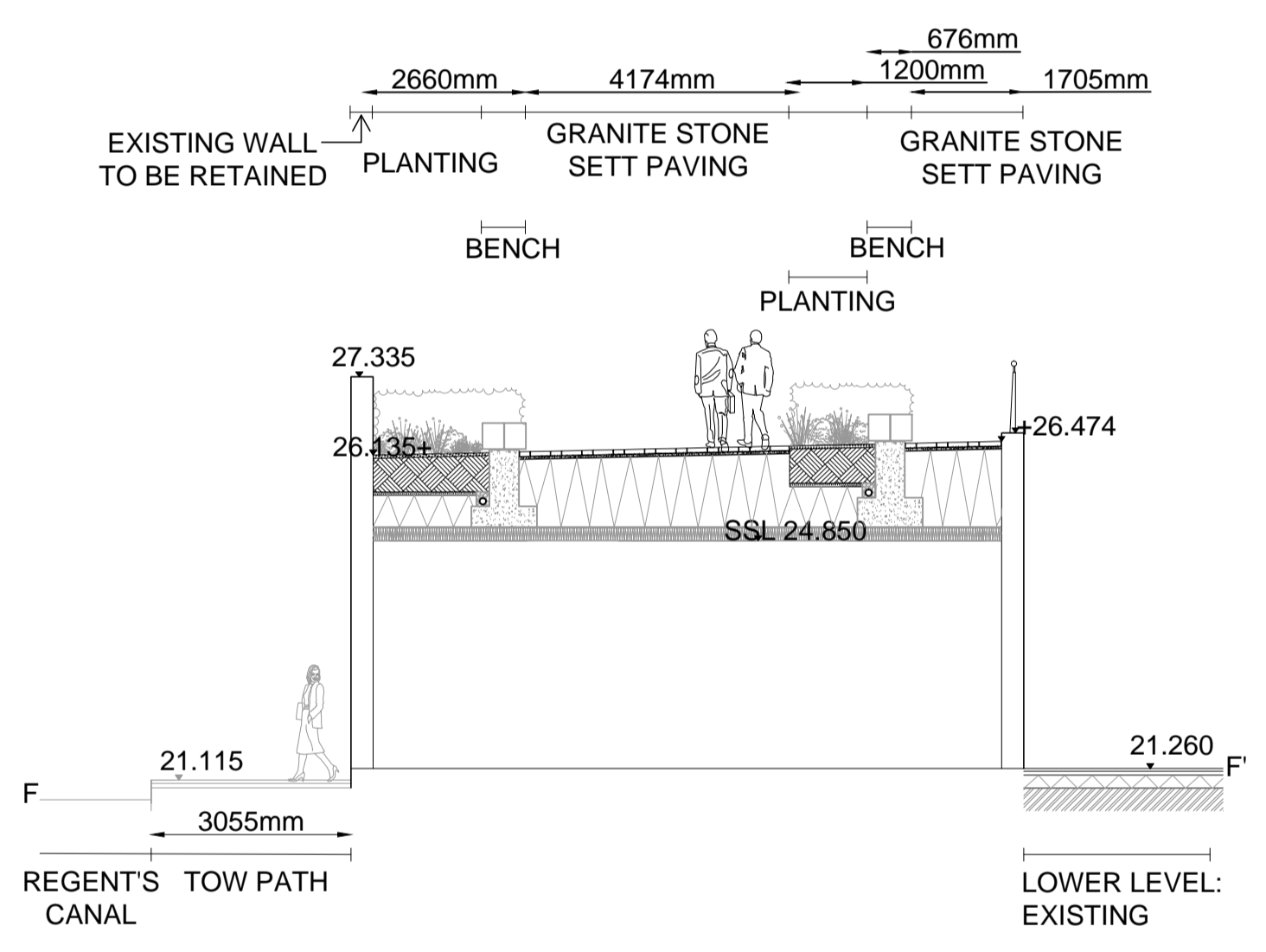

SECTION FF'
SCALE 1:100

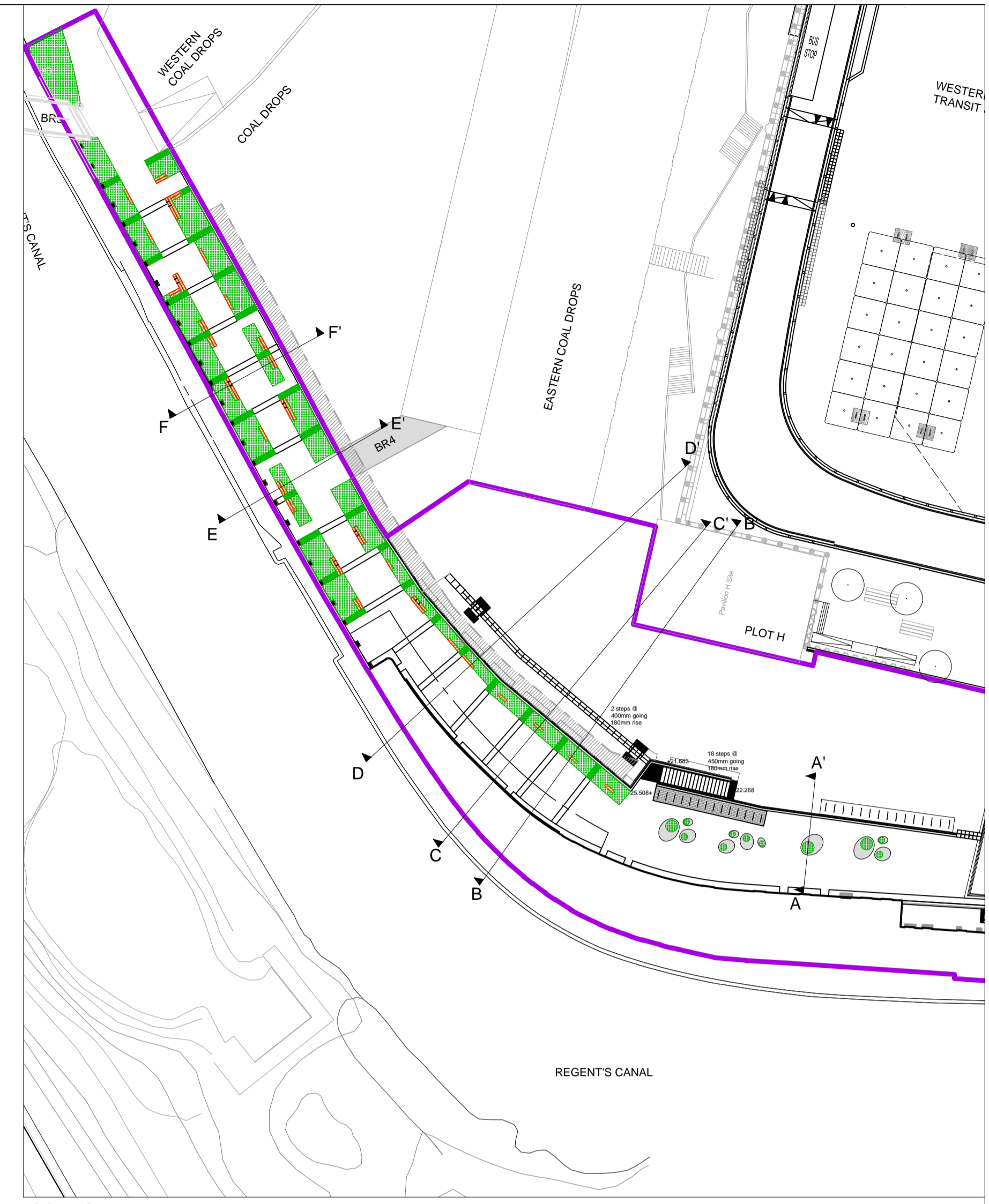

LOCATION PLAN
1:500@A1 / 1:1000@A3

FOR APPROVAL

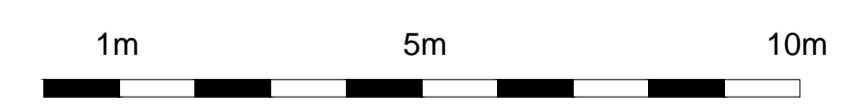

Project WHARF ROAD VIADUCT AND COAL DROPS RAMP	Drawing Title PUBLIC REALM LANDSCAPE SECTIONS DD', EE' & FF'	Revision	Date	R06 - Sections amended	24.01.14	Client KING'S CROSS CENTRAL GENERAL PARTNER LTD Address: 4 Stable Street, King's Cross, London, N1C 4AB Telephone: 020 3864 0200	Consultant TOWNSHEND Landscape Architects Unit 1E Zetland House London EC2A 4HJ Telephone: 020 7729 9333 Fax: 020 7729 3300 E-Mail: ita@townshenda.com	Project No.	Scale	Approved By	Drawing No. TOWN279.14(08)7002	Revision R11
		R01 - Central steps removed	11.11.13	R07 - Text amended	03.06.14			279.14	1:100@A1/ 1:200@A3	MA		
		R02 - Viaduct build ups amended	15.11.13	R08 Planter amended	05.06.14			Date	A1	MK		
		R03 - Viaduct hard and soft landscape amended	25.11.13	R09- Granite Set tags amended	25.09.14			JUNE '14				
		R04 - Bespoke seat added to conclude lower steps	05.12.13	R10- Tags amended	31.03.16							
		R05 - Viaduct hard and soft landscape amended	14.01.14	R11 - Top of wall levels amended	19.04.16							

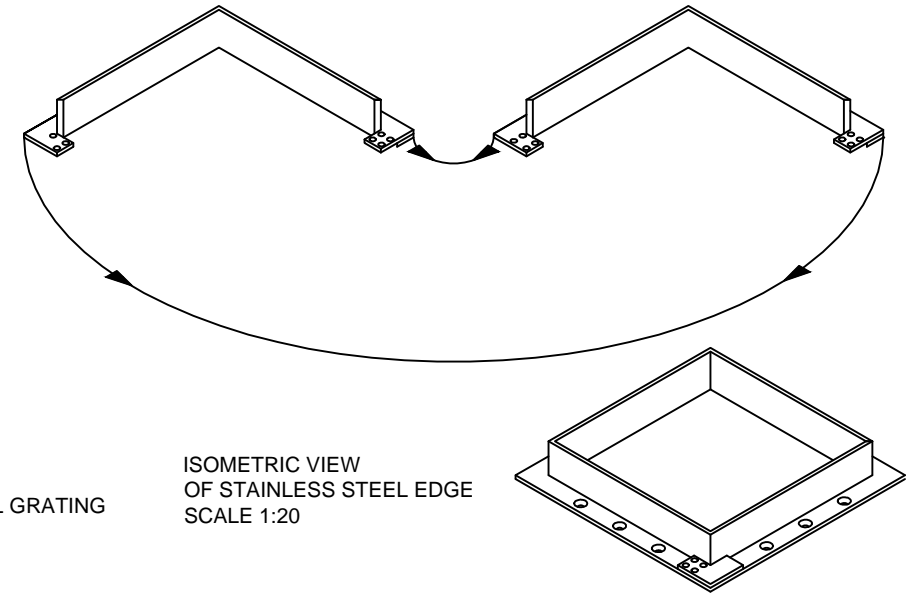
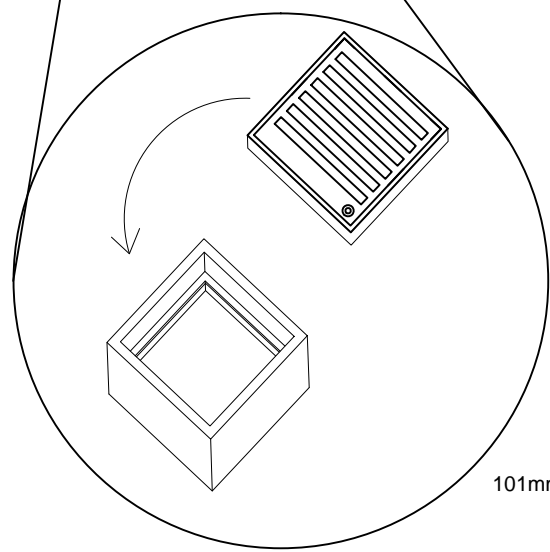
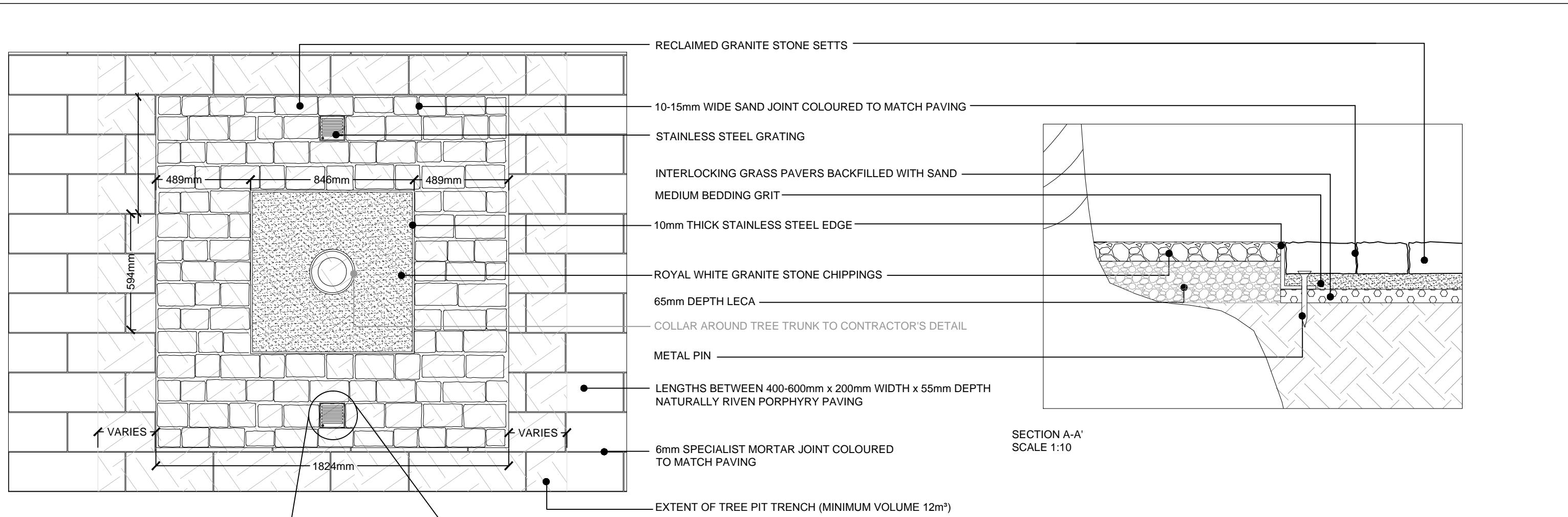

FOR APPROVAL

FOR TREE SURROUND SECTION
REFER TO DETAIL 279.14(08)4302

**DETAIL 3.01
TREE SURROUND PLAN**

- GENERAL NOTES**
1. Do not scale drawing.
 2. All setting out, levels and dimensions to be agreed on site.
 3. The dimensions of all materials must be checked on site before being laid out.
 4. Order of construction and setting out to be agreed on site.

Project WHARF ROAD VIADUCT AND COAL DROPS RAMP	Drawing Title DETAIL 3.01 TREE SURROUND PLAN	Revision	Date	Consultant TOWNSHEND Landscape Architects Unit 1E Zetland House London EC2A 4HJ Telephone: 020 7729 9333 Fax: 020 7729 3300 E-Mail: tla@townshendla.com	Project No.	Scale	Approved By	Drawing No.	Revision
		R00 -First Issue	17.01.14		279.14	1:20	MA		R02
Client KING'S CROSS CENTRAL GENERAL PARTNER LTD		R01 -Text amended	03.06.14		Date	Drawing Size	Drawn By		
		R02- Reissued without change	31.03.16		JUNE '14	A3	MK		TOWN279.14(08)4301

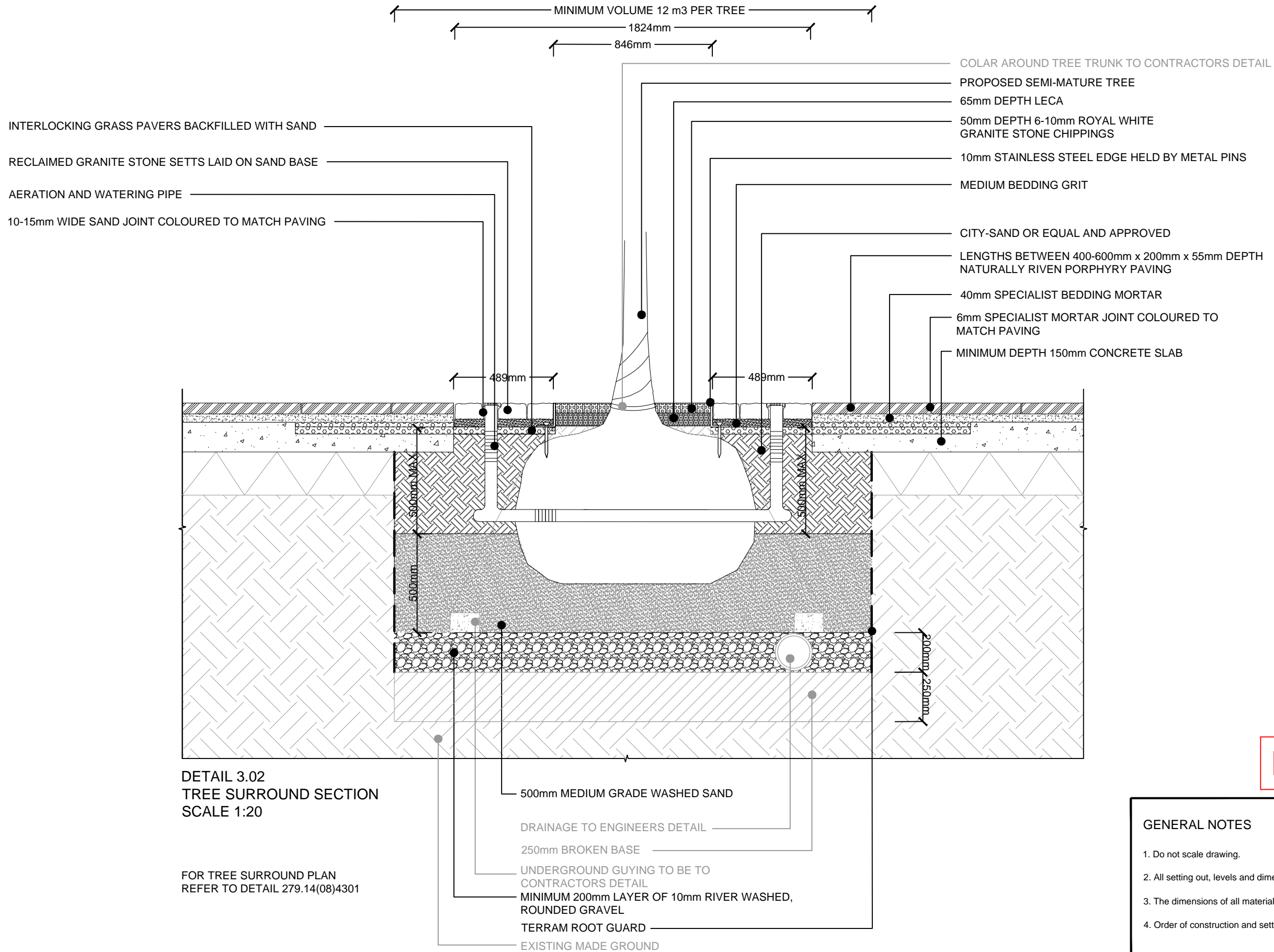

DETAIL 3.02
TREE SURROUND SECTION
SCALE 1:20

FOR TREE SURROUND PLAN
REFER TO DETAIL 279.14(08)4301

FOR APPROVAL

GENERAL NOTES

1. Do not scale drawing.
2. All setting out, levels and dimensions to be agreed on site.
3. The dimensions of all materials must be checked on site before being laid out.
4. Order of construction and setting out to be agreed on site.

Project WHARF ROAD VIADUCT AND COAL DROPS RAMP	Drawing Title DETAIL 3.02 TREE SURROUND SECTION	Revision	Date	Consultant TOWNSHEND Landscape Architects Unit 1E Zetland House London EC2A 4HJ Telephone: 020 7729 9333 Fax: 020 7729 3300 E-Mail: tla@townshenda.com	Project No.	Scale	Approved By	Drawing No.	Revision
		R00 -	17.01.14		279.14	1:20	MA		R02
Client KING'S CROSS CENTRAL GENERAL PARTNER LTD		R01 - Text amended	03.06.14		Date	Drawing Size	Drawn By		
		R02- Reissued without change	31.03.16		JUNE '14	A3	MK	TOWN279.14(08)4302	