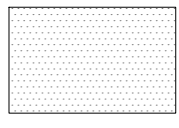
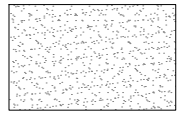
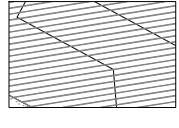
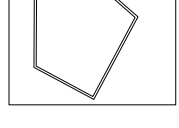
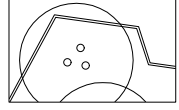

NOTES:

1. This drawing is to be read in conjunction with all relevant contract documentation from the design team, with any conflicting information to be brought to the attention of Farrer Huxley Associates in writing before commencing on site.
2. The contractor is to check and verify all levels and dimensions before construction. Any discrepancies are to be brought to the attention of Farrer Huxley Associates in writing before commencing on site.
3. All dimensions in mm, unless otherwise stated.
4. Do not scale from this drawing.
5. All sub base and concrete design and specification to engineer's details. All diagrams provided here are purely indicative.
6. Waterproofing of any element to be specified by others.
7. All proprietary products shall be installed in accordance with manufacturers written instructions.
8. Plant numbers are an indication only and plants should be ordered to suit site areas in accordance with scheduled plant densities.
9. Any proposed plant substitution shall be agreed with the landscape architect prior to ordering.

General drawing references:  
For FHA plans refer to "FHA 638 L" Series  
For FHA details refer to "FHA 638 D" Series

For GA Plans refer to '100' series  
For Hard landscape refer to '200' series  
For Levels and drainage refer to '300' series  
For Soft landscape refer to '400' series  
For Lighting refer to '500' series  
For Boundaries refer to '600' series  
For Furniture refer to '700' series  
For Water Features refer to '800' series  
For Setting Out refer to '900' series

-  Resin bound surface.  
Refer to FHA 659-D-201
-  Artificial grass.  
Refer to FHA 659-D-201
-  Timber decking.  
Refer to FHA 659-D-101
-  Steel planters.  
Refer to FHA 659-D-704
-  Tree planting, 2.5m high multi stem trees  
Refer to FHA 659-L-401, 402