

PRE-EXISTING GROUND FLOOR PLAN

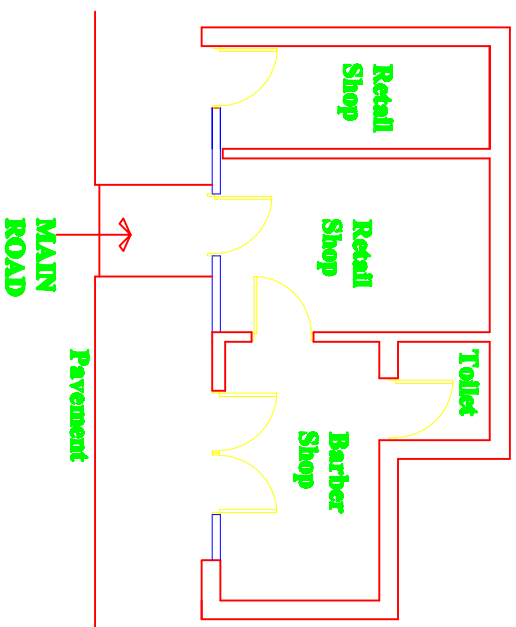

EXISTING GROUND FLOOR PLAN

**NOTE:**

PLEASE NOTE THAT BEFORE BUILDING WORKS COMMENCES IT IS THE RESPONSIBILITY OF BUILDER OR OWNER TO SERVE PARTY WALL NOTICES TO ALL NEIGHBOURS  
ALL DIMENSIONS TO BE CHECKED ON SITE. CONTRACTOR TO CHECK SITE THOROUGHLY BEFORE WORK STARTS & REPORT ANY DISCREPANCIES.

**LEGEND**

- ⑧ = SMOKE DETECTOR WITH SOUNDER
- ⦿ = EMERGENCY LIGHTING TO BS5838: Part 1 1999
- ⦿ = HEAT DETECTOR
- FD30 = 30 MINUTE FIRE RESISTING DOOR AND FRAME
- FD20 = 20 MINUTE FIRE RESISTING DOOR AND FRAME
- ⊞ = SMOKE SEALS FITTED TO PERIMETER OF DOOR
- 8C = SELF CLOSING DEVICE

SCALE	DESCRIPTION	INITIALS/DATE/PAGE

**SYLARC D. STUDIO**  
[\[sylarcstudio@gmail.com\]](mailto:sylarcstudio@gmail.com)  
[153 Orange.com\\_30713W](http://153.Orange.com_30713W)  
 PH: 07701002230

**PROJECT:**  
 122A, Drummond Street  
 NW1 2HN

**DWG TITLE**      **SCALE**  
**FLOOR PLAN**      1:100@A3

**CLIENT:**  
 M. Asman

**DWGNO.:**  
 SYL/16/122A/2

**DATE**      **DRAWN BY**  
 16/01/2016      MIZAN

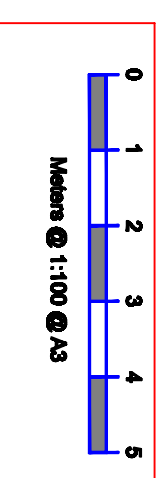

**ISSUE**  
A