

CONST. ISSUE

NOTES
 This drawing is to be read in conjunction with all other contract documents and specifications and all other consultants drawings. All levels and dimensions should be checked on site and any discrepancies notified to the C.A. prior to proceeding with works.

REVISIONS

NOTES

5 NUTLEY TERRACE
 LONDON NW3

PLANTER D1
 PLAN, ELEV AND SECTION
 RELEASE OF CONDITION

DWG No: 5NT/RC002

SCALE: 1 - 20 @A3

DATE: FEB 2016

belsize
architects

48 PARKHILL ROAD, LONDON NW3 2YP
 TEL 020 7482 4420 - FAX 020 7482 4186
 MAIL@BELSIZEARCHITECTS.COM

© COPYRIGHT
 NOT TO BE REPRODUCED OR USED
 WITHOUT PERMISSION

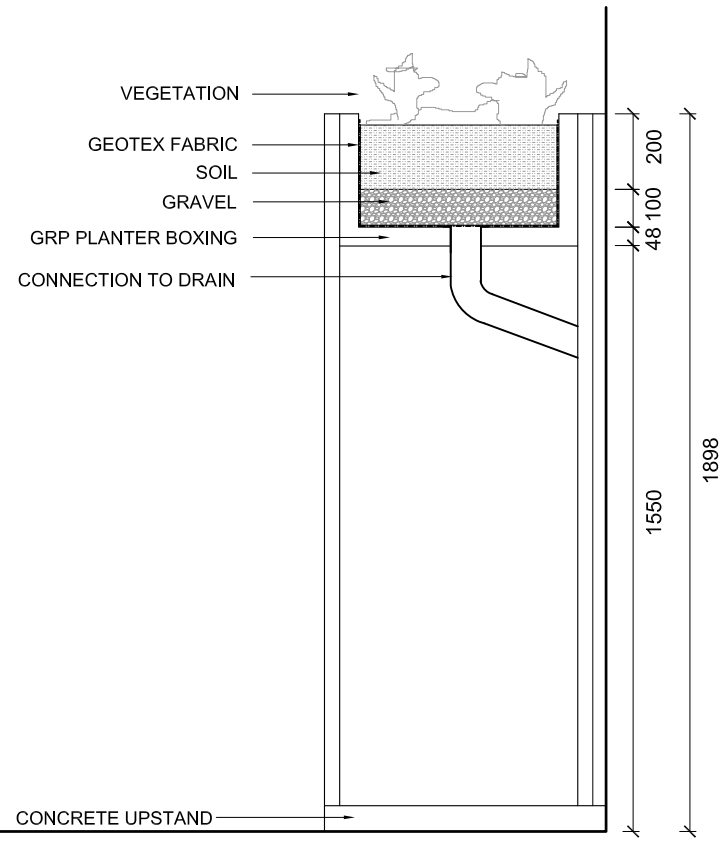

SECTION A

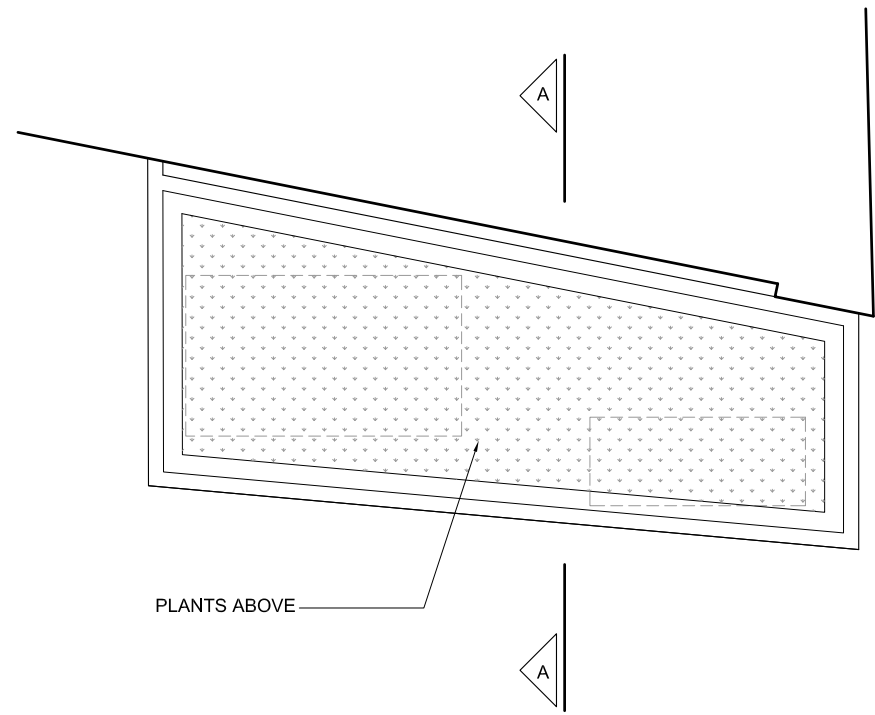

PLAN

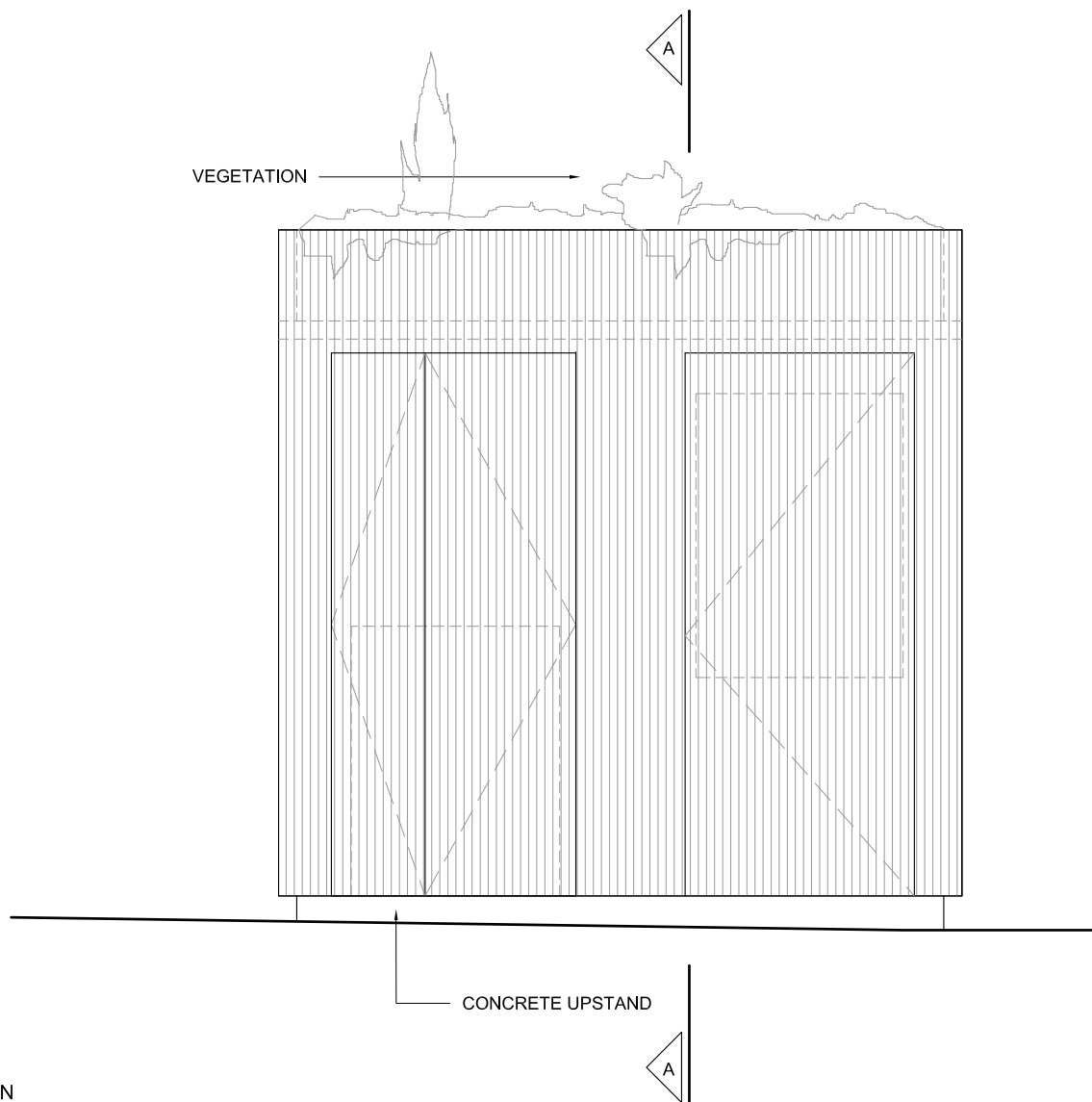

SIDE ELEVATION

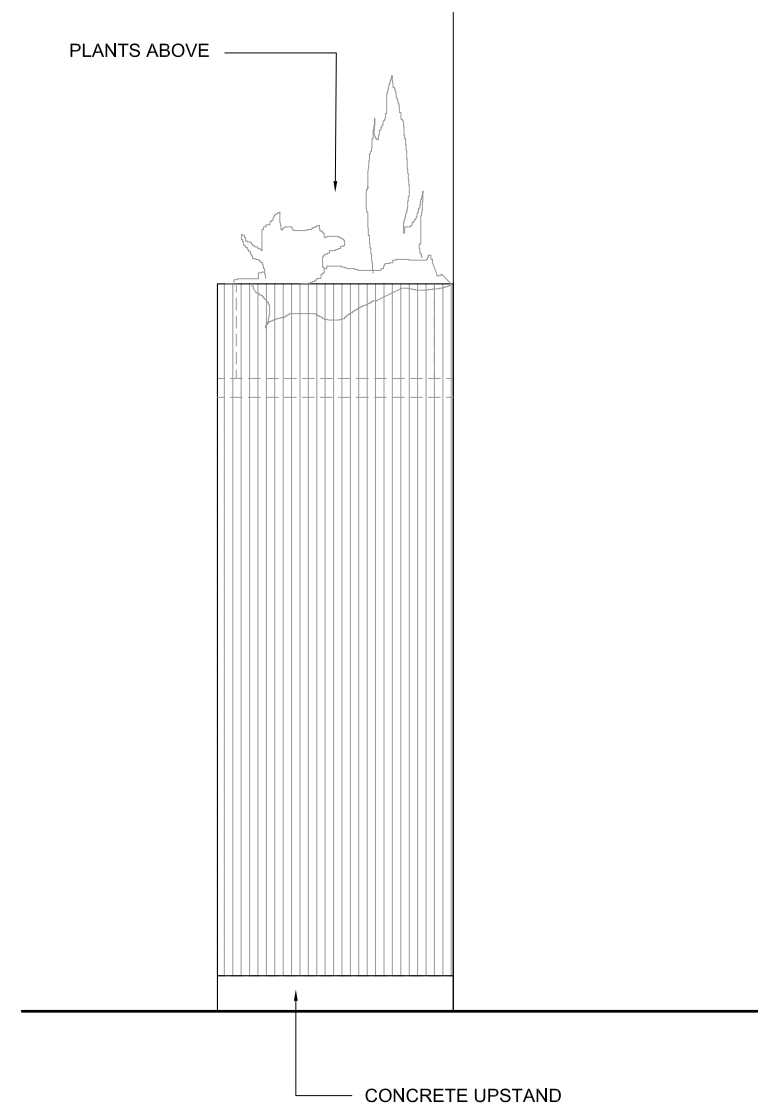

FRONT ELEVATION