



11 Rosslyn Hill
**Arboricultural
Method Statement**

Revision 3 August 2015

Report compiled by:

Matthew Jellings
Boward Tree Surgery (Oxford) Limited
The Log Quarry
Church Road
Long Hanborough
Witney
Oxfordshire
OX29 8JF



Re: Construction of a basement TV room, pool, sauna and toilet.

Arboricultural Method Statement:

All persons involved in the proposed construction works to be made aware of the importance of the retained trees at this site and to be familiar with the requirements of the works Method Statement and Tree Protection Measures.

The site to be subject to a visit from the Retained Arborist who will inspect for Arboricultural Method Statement compliance and correct implementation of the Tree Protection Measures as well as recording findings by means of photographs.

Site Specific Method Statement

The first phase of tree protection will include all the pre-construction works including the erection of the tree protection fencing/setting up of storage areas. As many prominent, mature and high value trees are on site a high level of protection is required during all phases. The next phase of tree protection will be needed for the construction works of the basement.

Phase 1: Pre-Construction & Demolition – See plan E.

TREWORKS

1. Tree 3762 to be felled and removed providing council consent is given for this. The hedgeline along the right of the entranceway to be removed. The canopy of trees 3757 and 3755 may need lifting to 5 metres in order to provide good access to construction vehicles. The necessity of the lifting works is to be decided upon at a later date. All tree works to be carried out in accordance with BS: 3998 (2010) – Recommendations for Tree works, and to be done in such a way as that no damage is caused to any of the retained trees.

CONSTRUCTION EXCLUSION ZONE (CEZ)

1. Tree Protection Fencing (TPF) to be positioned as per **plan E**, surrounding the trees 3751, 3761, 63 & 64, as well as all other trees in the rear garden. This is to provide the upmost level of protection during the demolition phase. The fencing will exclude construction workers and machines from entering the Tree Protection Zone. The type of fencing will be Heras supported with back braces where possible. Given the tight entrance way the fencing surrounding tree 3751 will have to be supported on blocks. The fencing around tree 3763 in the rear garden will have to be arranged as best as possible to protect the trees canopy and stay secure on the different garden levels. Please see Appendix 1 for Heras fencing details.
2. Tree protection fencing shall be maintained and retained for the full duration of the works, but can be removed for the soft landscaping workings on the paved area.
3. Potential areas for material storage are coloured yellow on **plan E**, and ground boards should be arranged under any area for material storage if on the grass area to the rear (can use plywood boards here for material storage). No activities or storage of materials whatsoever shall take place within the construction exclusion zone without the prior written

agreement of the LPA. Ground protection is also needed to cover the RPA of tree 3751 for to prevent construction traffic related compaction. An example of the quality of ground protection expected over the RPAs on site is shown in the appendix (Terram geocells). The ground protection over 3751's RPA must stay in place for the duration of the works, with the exception of when the paving is to take place in the rear garden.

4. All demolition works to take place from outside the RPAs of any of the retained trees on site.
5. Prestart meeting that includes the Retained Arborist, Architect and the designated construction company management team to explain the requirements of the Arboricultural Method Statement (AMS) and the Tree Protection Plan (TPP) measures.

Phase 2: Construction works & post construction remedial tree works

2. Where laying the foundation of the guest house may have a detrimental impact to the root system of tree 3779 the impact must be minimised (see below, section 3. i – iii). The full extent of rooting here will not be known until the foundations of the original guest house are taken up (leaving a 1m zone around the tree base). The magnolia has most of it's RPA in the CEZ but the western edge of the RPA may be lightly effected by the TV basement room, and again the measures found in 3.i-iii should be followed when digging in the RPA here.
3. Where the RPAs are infringed specific measures are required to minimise disturbance to the trees root systems. These include;
 - i. Only hand digging with minimal disturbance and soil level change to take place within RPAs.
 - ii. Any roots that are uncovered up to 25mm in diameter to be chased back to a suitable root junction and severed by means of appropriate pruning tools.
 - iii. Any roots that are uncovered above 25mm in diameter to be worked around in consultation with the retained arborist. While exposed any uncovered roots to be retained to be covered with a suitable hessian type material and kept moist.
4. Concrete and the run-off from it is particularly damaging to plant roots. A non-permeable geotextile barrier could be applied along the outer edge of the piling in the RPA of tree 3778 to prevent future contamination of the soil here (see **plan E**). Care to be taken by construction personal to prevent any spillage. Any accidental spillage to be cleared immediately and the Retained Arborist notified.
5. On completion of all works any trees that die, become seriously damaged, or die within 5 years of this development shall be replaced the following year by trees of the same size and species.
6. The hedgeline which was removed to allow access for vehicles to be replaced with similar species.

7. **Appendix 1**

Planning Category rating:

Category ratings are allocated based on the current condition of a tree in its current surroundings assuming the recommendations of this report are carried out. No consideration is given to any specific development proposal when allocating category ratings. For a full break down of tree categorisation see below:

Category A trees are those which have high visual amenity value, are in good structural and physiological condition and are expected to contribute for at least another 40 years.

Category B trees are those which would be considered as category A trees but which are of lower value, poorer structural condition, or which are expected to contribute for less than 40 years.

Category C trees are those which have low amenity value, are in poor condition, or are expected to contribute for less than 20 years.

Category U trees are those which are expected to contribute for less than 10 years due to serious defects. As is common in risk management, where there is doubt, the precautionary principal may be applied.

In certain circumstances trees may be considered of higher value due to cultural or ecological reasons. If this is the case it will be made clear in the tree data tables.

Sub-categories:

Sub- categories of 1, 2 or 3 are included in the tree data tables and are defined as follows:

Sub-category 1 trees are those with 'other arboricultural value'

Sub-category 2 trees are those with 'landscape value'

Sub-category 3 trees are those with 'cultural or conservation value'

Suggested signage for tree protection fencing:

TREE PROTECTION AREA KEEP OUT!

TREES ENCLOSED BY THIS FENCE ARE PROTECTED BY PLANNING CONDITIONS AND ARE SUBJECTS OF A
TREE PRESERVATION ORDER
(TOWN & COUNTRY PLANNING ACT 1990)

CONTRAVENTION OF TREE PRESERVATION ORDER MAY LEAD TO CRIMINAL PROSECUTION

THE FOLLOWING MUST BE OBSERVED BY ALL PERSONS:-

- THE PROTECTIVE FENCING MUST NOT BE REMOVED
- NO PERSON SHALL ENTER THE PROTECTED AREA
- NO MACHINE OR PLANT SHALL ENTER THE PROTECTED AREA
- NO MATERIALS SHALL BE STORED IN THE PROTECTED AREA
- NO SPOIL SHALL BE DEPOSITED IN THE PROTECTED AREA
- NO EXCAVATION SHALL OCCUR IN THE PROTECTED AREA

**ANY INCURSION INTO THE PROTECTED AREA MUST BE
WITH THE WRITTEN PERMISSION OF THE LOCAL PLANNING AUTHORITY**

Required construction method of Tree Protection Fencing:

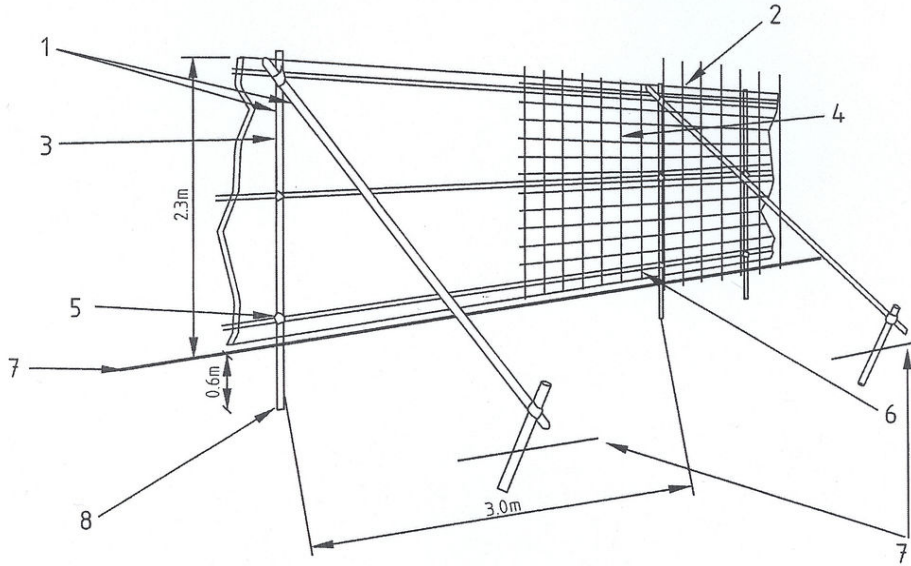

- | | |
|--|--|
| 1 Standard scaffold poles | 5 Standard clamps |
| 2 Uprights to be driven into the ground | 6 Wire twisted and secured on inside face of fencing to avoid easy dismantling |
| 3 Panels secured to uprights with wire ties and, where necessary, standard scaffold clamps | 7 Ground level |
| 4 Weldmesh wired to the uprights and horizontals | 8 Approx. 0.6m driven into the ground |

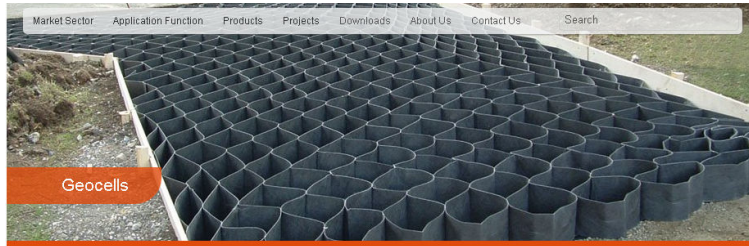

Tree Root Protection / Load Platform Geocell

Application Function
 Ground Stabilisation | Containment / Confinement | Erosion Control

Market Sectors
 Highways | Coastal & waterways

Products:
 Terram Geocell 25/10 & 22/20

The Terram geocell is a cellular confinement system that is used to protect tree roots from damage caused by heavy vehicles, particularly where a Tree Protection Order (TPO) is in force. Conventional construction would be invasive and trees are sensitive to disturbance.

The geocell is manufactured from one of the Terram geotextiles range which means that air and water are free to move across the root area from cell to cell. The geocell supplied in the form of flat-packed panels which expanded on site to form a much larger honeycomb area of interconnected cells. The panels are secured to the ground using steel pins which are also available to purchase.

The road or parking area can be constructed once the roots have been covered by the geocell and filled with a granular material. The geocell ensures that axle loads are spread laterally rather than applied vertically. This also minimises compaction beneath the traffic line which would be harmful to the roots as they could become starved of oxygen and moisture. Without the cellular system, loads



We use cookies to help provide you with the best possible online experience and to gather anonymised, aggregate website usage data. You can find out more about the cookies we use and how to disable them in our [Cookie Policy](#). By using our website you agree that we may place cookies of the type listed in our Cookie Policy on your device. [Close X](#)

An example of suitable ground protection within trees RPA would be the TERRAM Tree root protection geocell.