

7) Dimension of the PV field (Visible Part of the installation)

1°) Width calculation of the visible field

Dimension of the photovoltaic field	
Field width (mm)	
PV field centered on rake direction	$X = 1020 \times N_{bx} + (2 \times 40)$
Lateral eave installation	$X = 1020 \times N_{bx} + (2 \times 25)$

N_{bx} : Number of column of PV module

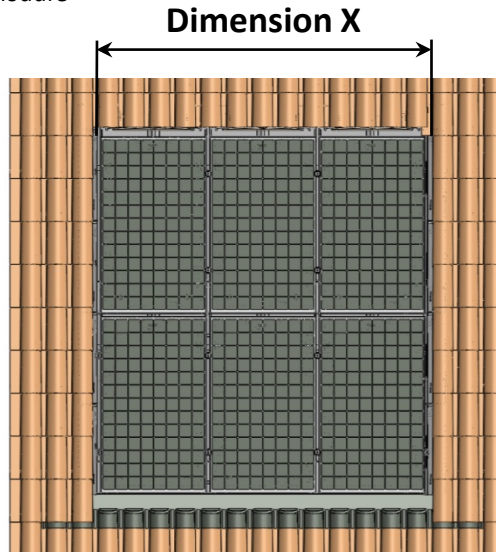

a) Common installation (with tiles on both side)

Ex : $(1020 \times 12) + (2 \times 40) = 12320$

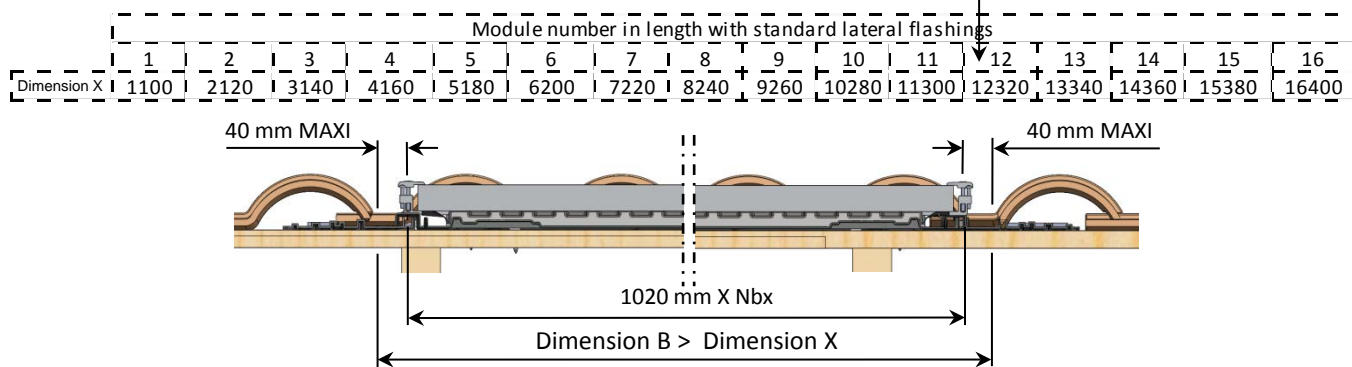

Positioning the photovoltaic field

Dimension B must be positioned with the tiles hollow.

b) Edge installation (no tiles on each side)

Ex : $(1020 \times 12) + (2 \times 25) = 12290$

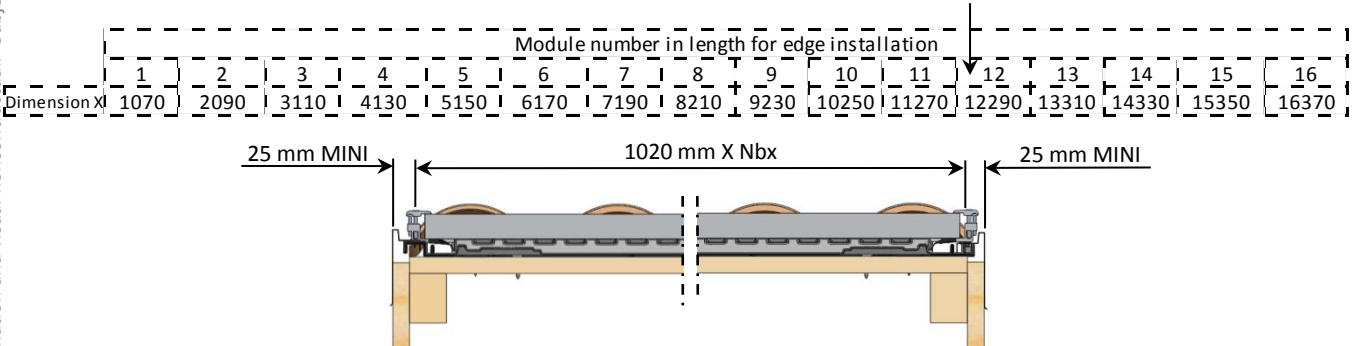

Model "L-1" 60 Cells 6" Portrait

7) Dimension of the PV field (Visible Part of the installation)

2°) Height calculation of the visible field

Dimension of the photovoltaic field	
Field height (mm)	
PV field centered on rake direct	$Y = \text{Step} \times (\text{Nby}-1) + 1614 + 114$
Gutter / eave installation	

Step : Step of the system in rake direction, see table below

Nby : Number of line of PV module

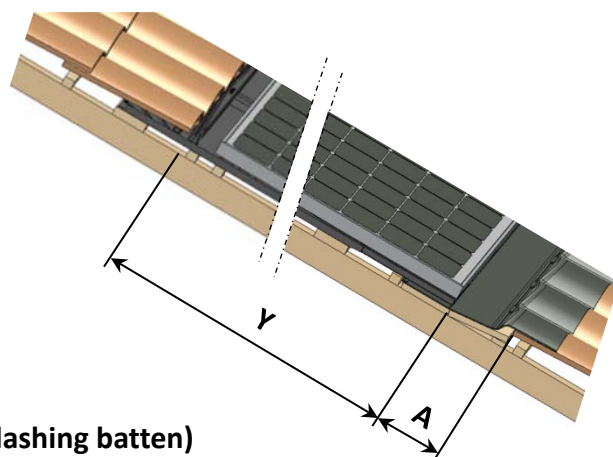
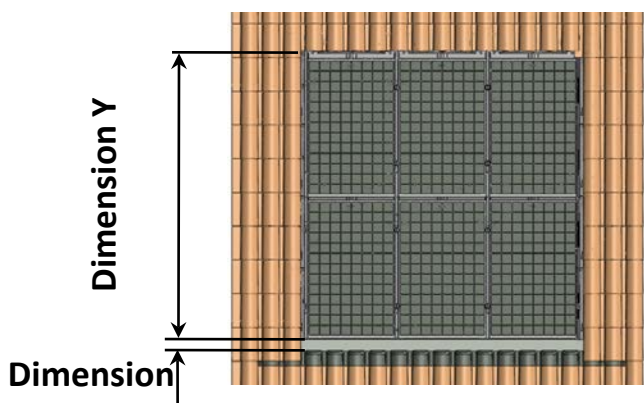

A a) Determination of dimension A (Bottom flashing batten)
The « C » dimension is the Minimum batten width necessary to avoid reverse slope on the bottom flashing. It's possible to use a wider batten, this will simply raise up the PV field.

Roof slope (°)	Minimum batten width C dimension (mm)	Mini A dimension (mm)
from 10 to 12	250	260
from 13 to 16	220	230
from 17 to 19	180	190
from 20 to 24	150	160
from 25 to 50	120	130

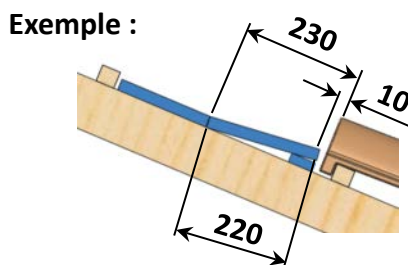
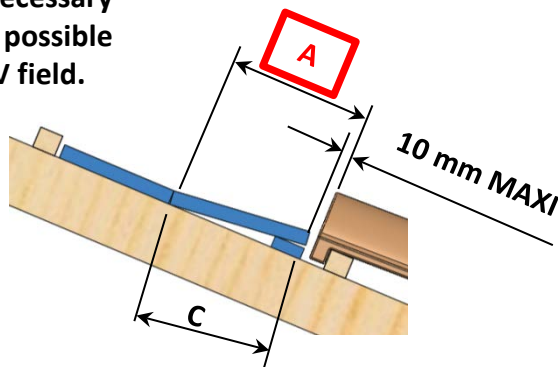

b) Determination of dimension Y

Warning : Please check the PV module compatibility list on : www.irfts.com

System vertical step	Length PV module (lg)			
	≤ 1645	$1646 \leq lg \leq 1665$	$1666 \leq lg \leq 1685$	
	1655	1675	1695	
Dimension Y				
modules number in height	1	1728	1728	1728
	2	3383	3403	3423
	3	5038	5078	5118
	4	6693	6753	6813
	5	8348	8428	8508
	6	10003	10103	10203
	7	11658	11778	11898

Ex: $(1655 \times (3-1)) + 1614 + 114 = 5038$

**Dimension of the visible field =
Dimension Y + Dimension A**

9) Instruction for the assembly of the Easy-Roof system

9.1.1) PV field centered on rake direction

This section of the installation manual relates only to installation of PV field centered in the rake direction. For the installations on the eave go directly on page 22 of this document

Remove the tiles of the photovoltaic field, for L and H to see page 12 and 13

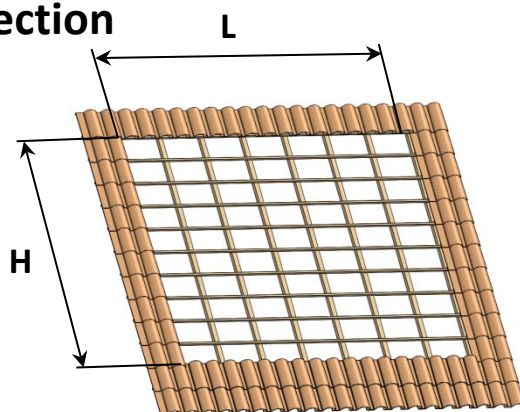

9.1.2) Definition of bottom flashing support batten

1° Define the thickness of the bottom flashing batten according to the thickness of the support batten (d)*.

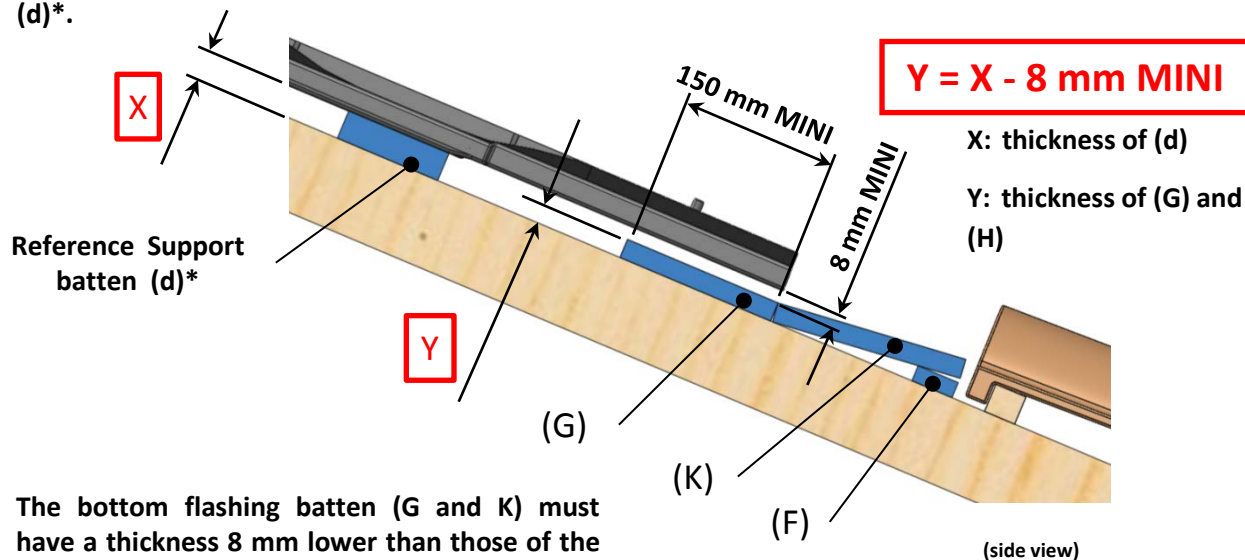

The bottom flashing batten (G and K) must have a thickness 8 mm lower than those of the support batten (d).

2° Position the batten (F) in order to have the top of the bottom flashing batten (H) flush with the water flow of the tile, eventually slightly higher (a few millimeters).

